

# CT Series - CG Non-Refrigerated Countertop Cases

## Models

CG28

CG38



*Non-refrigerated service cases for counters*

## Standard Features

- Black interior
- Black exterior
- Glass ends
- Straight front glass
- Clear glass rear swinging doors
- Lighted solid shelves
- T-8 top light
- Electrical leads
- Designed for service or self-service applications
- ETL certified to CAN/CSA 22.2, conforms to UL 65 & NSF 2

## Options

- Stainless steel interior
- Stainless steel exterior

ONE PART PASSION, TWO PARTS SCIENCE



# Specifications - CG Cases

Model	LxDxH
CG28	28"x25"x30-1/2"
CG38	38"x25"x30-1/2"

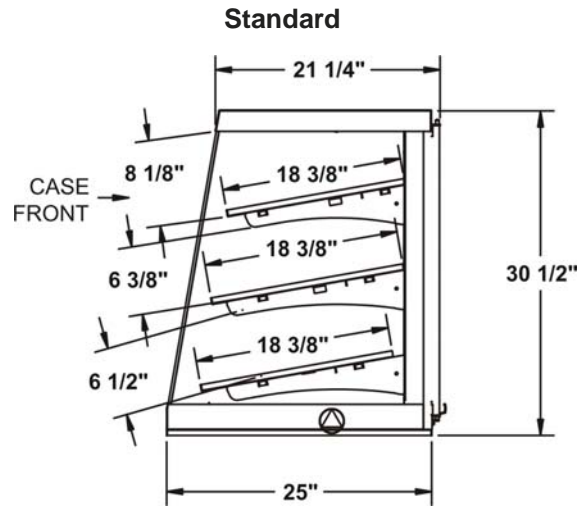

## IMPORTANT NOTES

## INTENDED ENVIRONMENT

Integrated ambient product temperature.

## INTENDED USE

Packaged non-refrigerated products

INFORMATION IS SUBJECT TO CHANGE WITHOUT NOTICE.



For more information on any of our products or services please visit us on the web at:  
[www.structuralconcepts.com](http://www.structuralconcepts.com)