

Impulse![™]
S E R I E S

INSTALLATION & OPERATING MANUAL

PN 99425

SELF-SERVICE COUNTERTOP UNIT



Illustration shown may not
reflect every feature or option
of your particular case.

Model: CSC3223.....31 1/2" L x 46 3/8" H* x 23 1/8" D

**Includes Top Sign*



Structural

Concepts

888 E. Porter Road · Muskegon, MI 49441 Phone: 231.798.8888 Fax: 231.798.4960 www.structuralconcepts.com

TABLE OF CONTENTS

OVERVIEW AND WARNINGS	3
INSTALLATION	4
START-UP AND OPERATION	5
MAINTENANCE FUNDAMENTALS	6
LIGHT FIXTURES - FLUORESCENT	7
LIGHT FIXTURES - LED	8
SERIAL LABEL LOCATION & INFORMATION LISTED / TECH INFO & SERVICE.....	9
TROUBLESHOOTING	10
ILLUSTRATED PARTS BREAKDOWN	12
PARTS LIST	13
CLEANING SCHEDULE.....	14
WARRANTY.....	15
TECHNICAL SERVICE.....	16

OVERVIEW

- The Structural Concepts Renaissance service non-refrigerated cases are designed to merchandise unpackaged bakery products at ambient temperatures.
- These cases should be installed and operated according to the following instructions to insure proper performance.
- This unit is designed for the display of products in ambient store conditions where temperatures and humidity are maintained at a maximum of 75° F and 55% relative humidity.



WARNING
Risk of Electric Shock.
Disconnect Power Before Servicing Unit



CAUTION
Lamps have been treated to resist breakage and must be replaced with a similarly treated lamp.

INSTALLATION

Remove Unit From Skid

- Position the unit near a suitable electrical outlet.
- Caution: Case must always remain supported or center of gravity will allow case to fall.
- Slide unit to rear of skid and tip backward off skid.

Position and Level Units

For your safety, equipment is furnished with a properly grounded cord connector. Do not attempt to defeat the grounded connector.

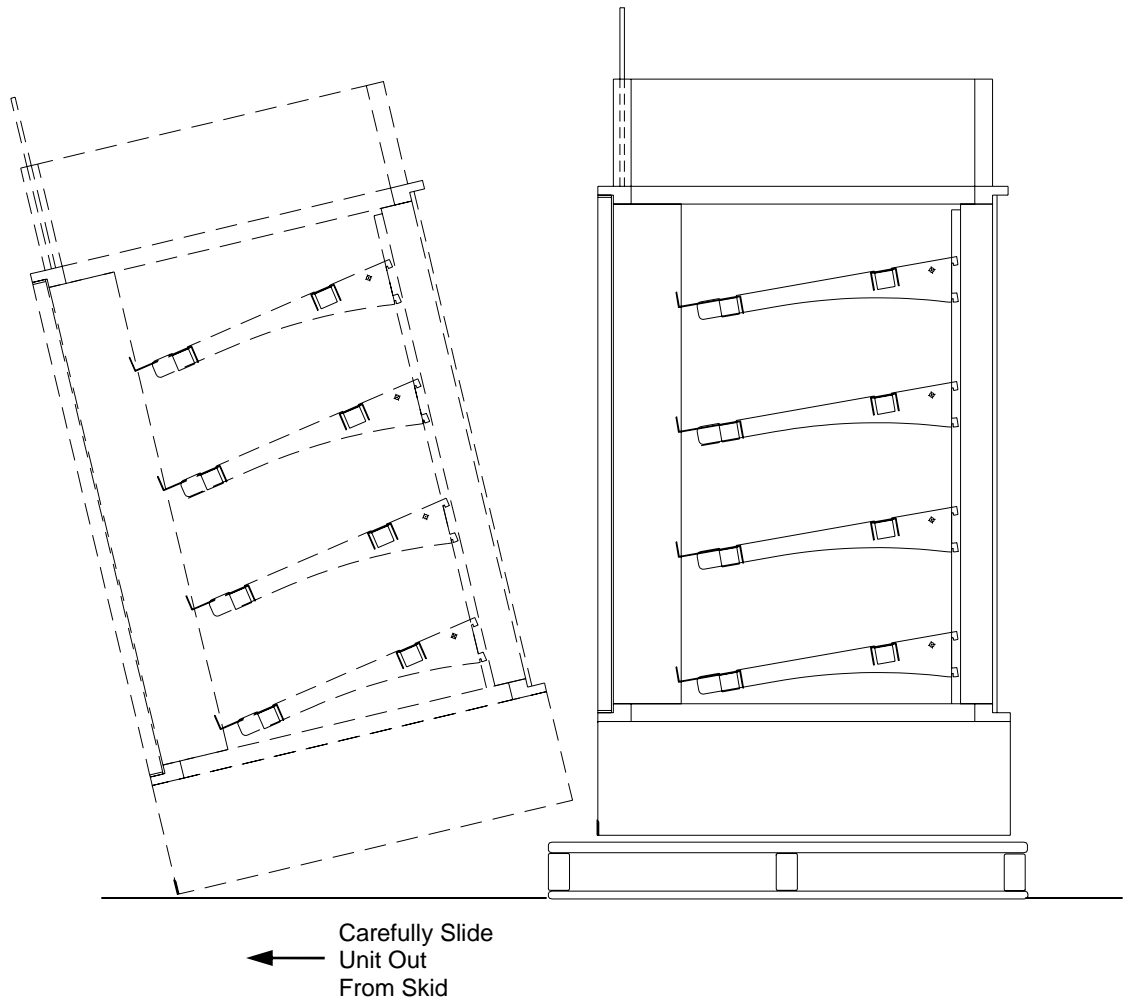

START-UP AND OPERATION

For your safety, equipment is furnished with a properly grounded cord connector. Do not attempt to defeat the grounded connector.

Set-up Counter Top Unit

- Remove case from skid and place on counter in the position at which the case will reside.
- **Note:** The National Sanitation Foundation (NSF) requires the following two steps be done before this case can be used.
- 1. *After case is in position, apply a steady bead of silicone around the base and counter top.*
- 2. *Allow 24 hours for the silicone to dry before using the case.*
- Electrical 120V stub up connections are provided in the light switch box.

Merchandiser Start-Up

- Do not use an extension cord with this appliance.
- Do not operate this equipment with a damaged cord, plug or outlet.
- Insure the power switch is off.
- Plug cord into a certified 120V electrical outlet with ground.

Fluorescent Lights Only

- Turn lights on.
 - On the counter top unit, the light switch is located behind the tissue box.
 - On floor models without a storage door the switch is located at the front base of the unit under the front panel on the left hand side.
 - On floor models with a storage door, the light switch is located inside the base storage area on the left hand side.
- Lights should come on at the same time. First time lighting may require a short warm up period for the bulbs. Slightly dim or a flickering of new bulbs is normal.

LED Lights Only

- Lights will come on when case is plugged in.

Tissue Dispenser

- Remove tissue dispenser.
- Place a tissue box into the dispenser as shown.

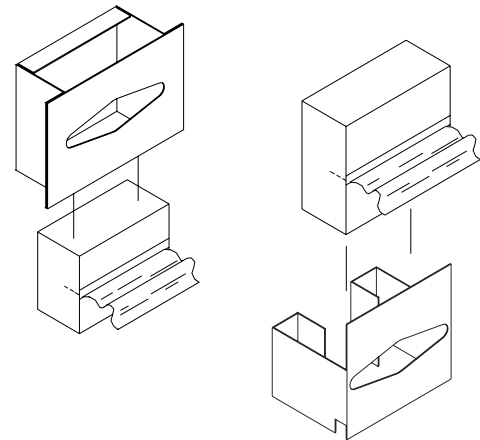
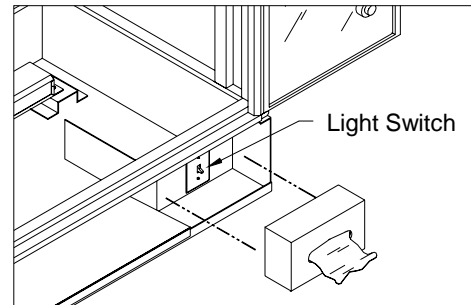

— Tissue Dispensers —

Shelf Assembly Removal

- Shelves can be removed for repositioning, removal (for individual merchandising requirements) and cleaning.
- Slide the front shelf support back rotate up and lift straight up to separate from brackets.
- Slide the rear shelf support back rotate up and lift straight up to separate from brackets.
- Remove brackets. Note it may be necessary to remove the nylon shipping bracket retainers. Pliers will be required to accomplish this task.

Removing of Decking

- Remove lower shelf assembly.
- Remove interior deck by pushing up from underneath in the bag storage area.

Door “Hold Open” Feature

To reposition the shelving or restock the shelves, it is first helpful to use the door ‘hold open’ feature.

- Open the door all the way (See light fixture).
 - **Caution damage will result if pin is not lowered before attempting to close the doors.**
 - Inside the unit, at the top of each door hinge, is the pin slide cover.
- Slide the pin cover up until the pin extends approximately 1/2 inch above the door hinge.
- Release the door assembly allowing the pin to rest on the outer door frame.
- To close, fully open the door and retract the pin into the hinge and allow the door to close.

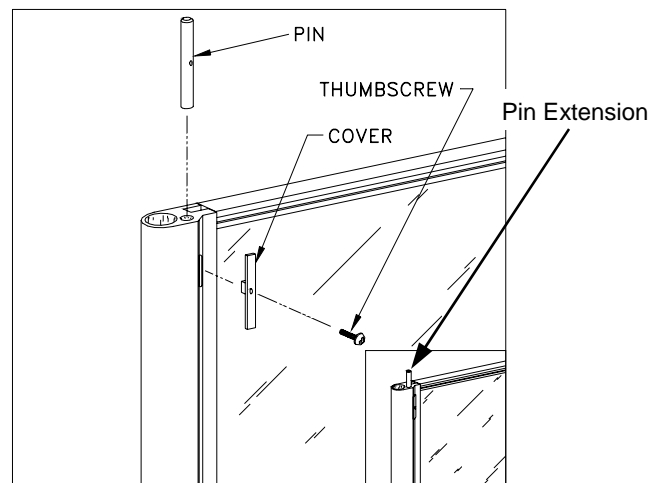
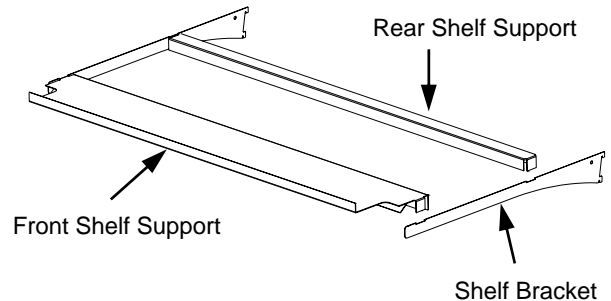
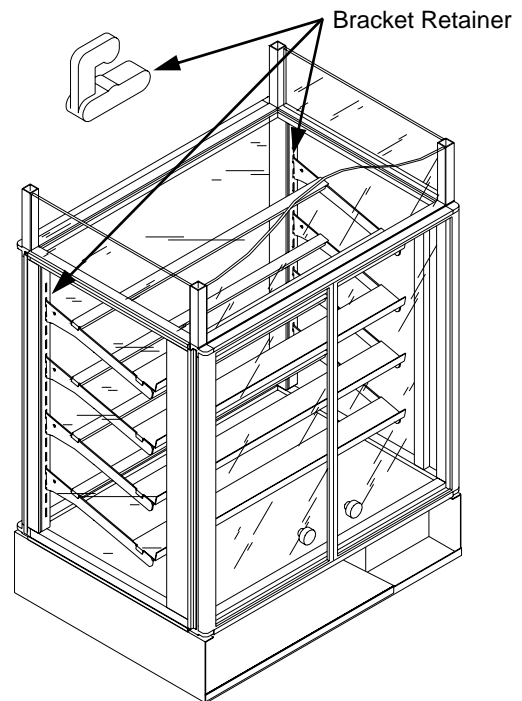

LIGHT FIXTURES - FLUORESCENT (SEE NEXT PAGE FOR LED LIGHT FIXTURES)

Light Fixtures

Light fixtures are located on the sides of each door assembly, both sides (just inside the doors).

- Open the door all the way.
- Access lamp by removing the lamp cover/diffuser.
 - Applying gentle squeezing pressure to lamp cover and rotating will release the cover.

Removal of lamp:

- Press bulb down until top contacts are clear of the upper socket.
- Tilt top of bulb away from the upper socket and lift bulb out.
- Replace bulb by performing this operation in reverse order.

Light Ballast Access

- Remove electrical power from the unit.
- Engage door "hold open" mechanism.
- Remove shelving.
- Remove interior deck by pushing up from underneath in the bag storage area.

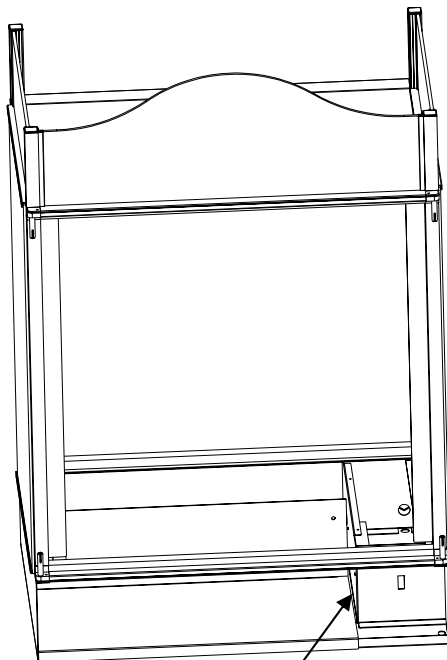

Ballast

Light Assemblies
(Inside Edge - Both Sides)

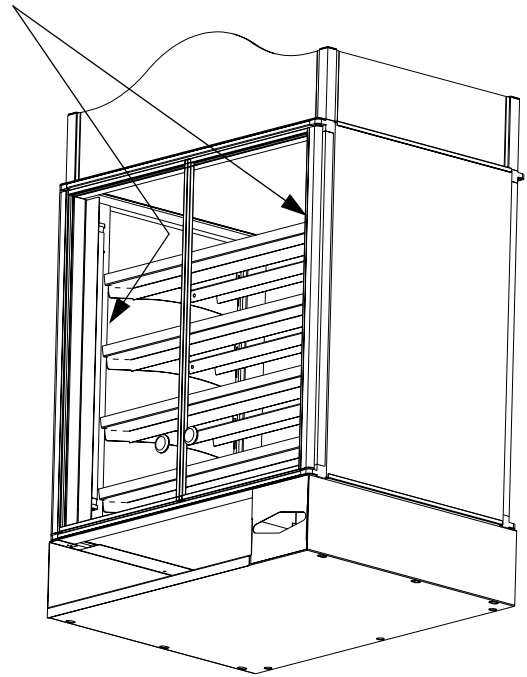

Light Assembly

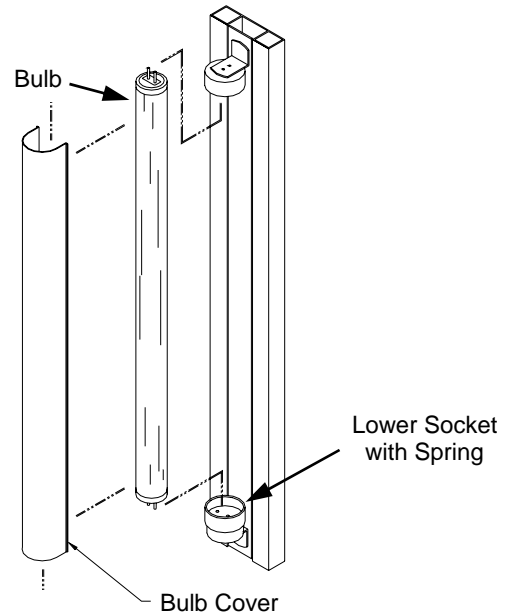

LIGHT FIXTURES - LED (SEE PREVIOUS PAGE FOR FLUORESCENT LIGHT FIXTURES)

Light Fixtures

- Light fixtures are located on the sides of each door assembly, both sides (just inside doors).
- See illustrations at right.

LED Light Fixture Removal

Removal of lamp:

- This case is provided with LED lights which will rarely require change-out.
- Contact Structural Concepts' Technical Service Department for replacement parts (see the Technical Service section of operating manual).

Replacement of lamp:

- To replace LED Light Fixture, disconnect the existing LED light from its brackets and self-adhesive tape. Replace.
- **Note:** LED Light and Plug must be connected in a specific manner or they will not work.
- Flat edge of plug must connect to flat edge of LED light. See illustration below.

LED Power Supply Access

- Disconnect electrical power from unit.
- Engage door "hold open" mechanism.
- Remove shelving.
- Remove interior deck by pushing up from underneath in bag storage area.

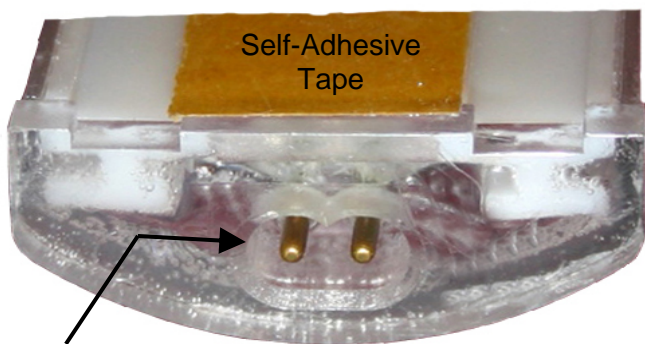

LED's
Oval
Form

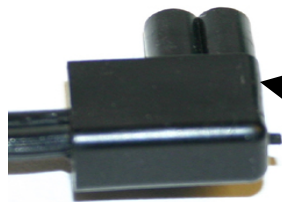



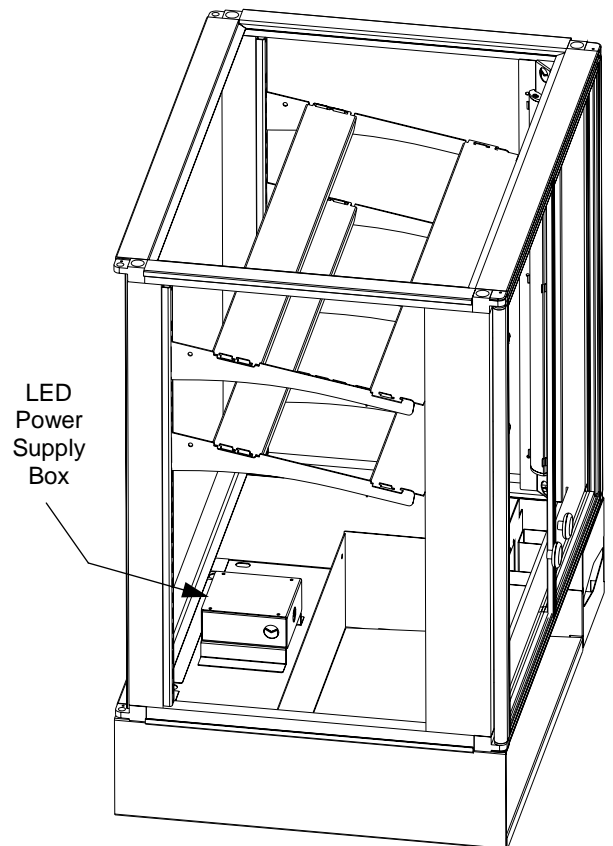
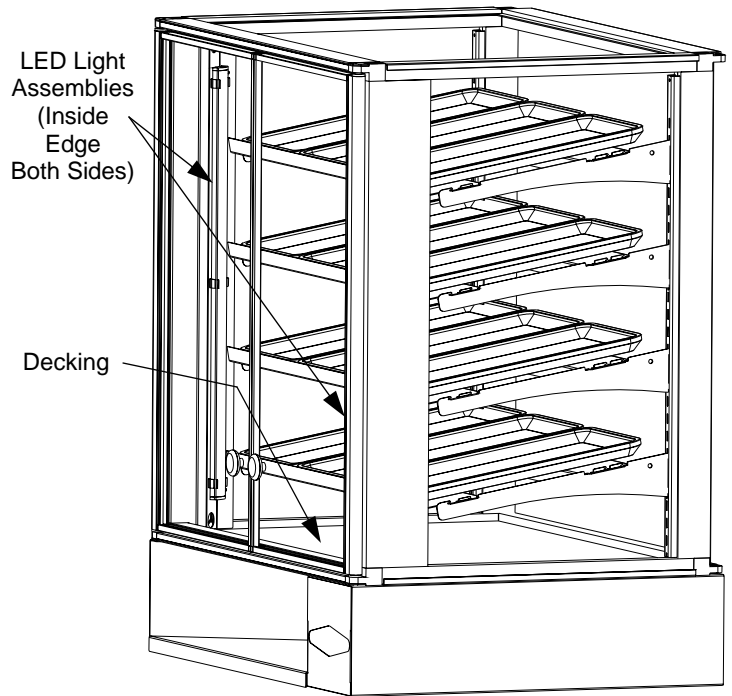

Plug's Oval
Form





View of case with decking removed to access

Serial Label Location & Information Listed / Technical Information & Service

- Serial labels are located near the electrical access on your case.
- Serial labels contain electrical, temperature & refrigeration information, as well as regulatory standards to which the case conforms.
- For additional technical information and service, see the *TECHNICAL SERVICE* page in this manual for instructions on contacting Structural Concepts' Technical Service Department.
- See images below for samples of both refrigerated and non-refrigerated serial labels.

 <p>888 E. Porter Rd · Muskegon, MI 49441</p>				MODEL HV74RSS SCROLL SERIAL NO.
FOR PARTS AND SERVICE CALL 1-800-433-9489				
 		ELECTRICAL RATING		120/1/60 24A
3048256		REFRIGERANT		R404A AMOUNT ?? OZ
CONFORMS TO UL STD 471		DESIGN PRESSURE		HIGH 450 LOW 200
CONFORMS TO NSF STD 7		MINIMUM CIRCUIT		30A
CERTIFIED TO CAN/CSA STD C22.2 NO 120		MAXIMUM OVERCURRENT		30A
Super Heat Temp		8-10°F		
BTUH Requirements		9,738 BTUH @ 20° F SST		
Defrost		6 defrosts per day, 45° F termination, 45 min. failsafe		

----- Sample Serial Label For Refrigerated Case -----

 <p>888 E. Porter Rd · Muskegon, MI 49441</p>				PC5682 txtRemote txtSerialNumber
		120 VOLTS 60 HZ SINGLE PHASE 1.84AMP		
3048256 CONFORMS TO UL STD 65 CERTIFIED TO CAN/CSA STD C22.2 NO 120		FOR PARTS OR SERVICE CALL STRUCTURAL CONCEPTS AT 1-800-433-9489		
		N/A		SAMPLE ONLY

----- Sample Serial Label For Non-Refrigerated Case -----

TROUBLESHOOTING

Case Lights Not Working	Check bulbs for proper installation and connection.
	Check for burned out bulbs.
System is not Operating	Confirm the utility power is on.
	Check the circuit breaker box for tripped circuits.

ILLUSTRATED PARTS BREAKDOWN (STANDARD CASE ONLY)

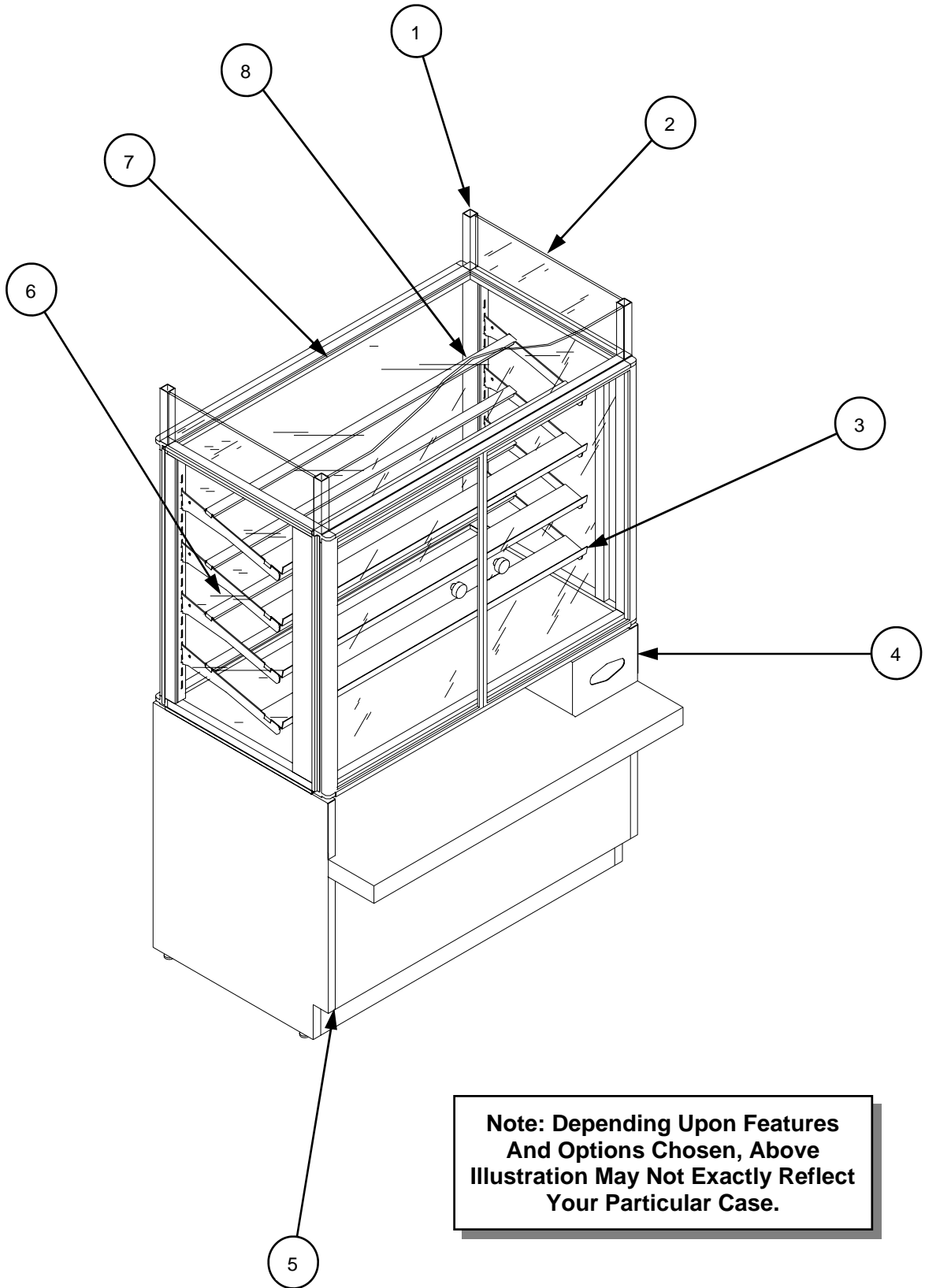

ILLUSTRATED PARTS BREAKDOWN

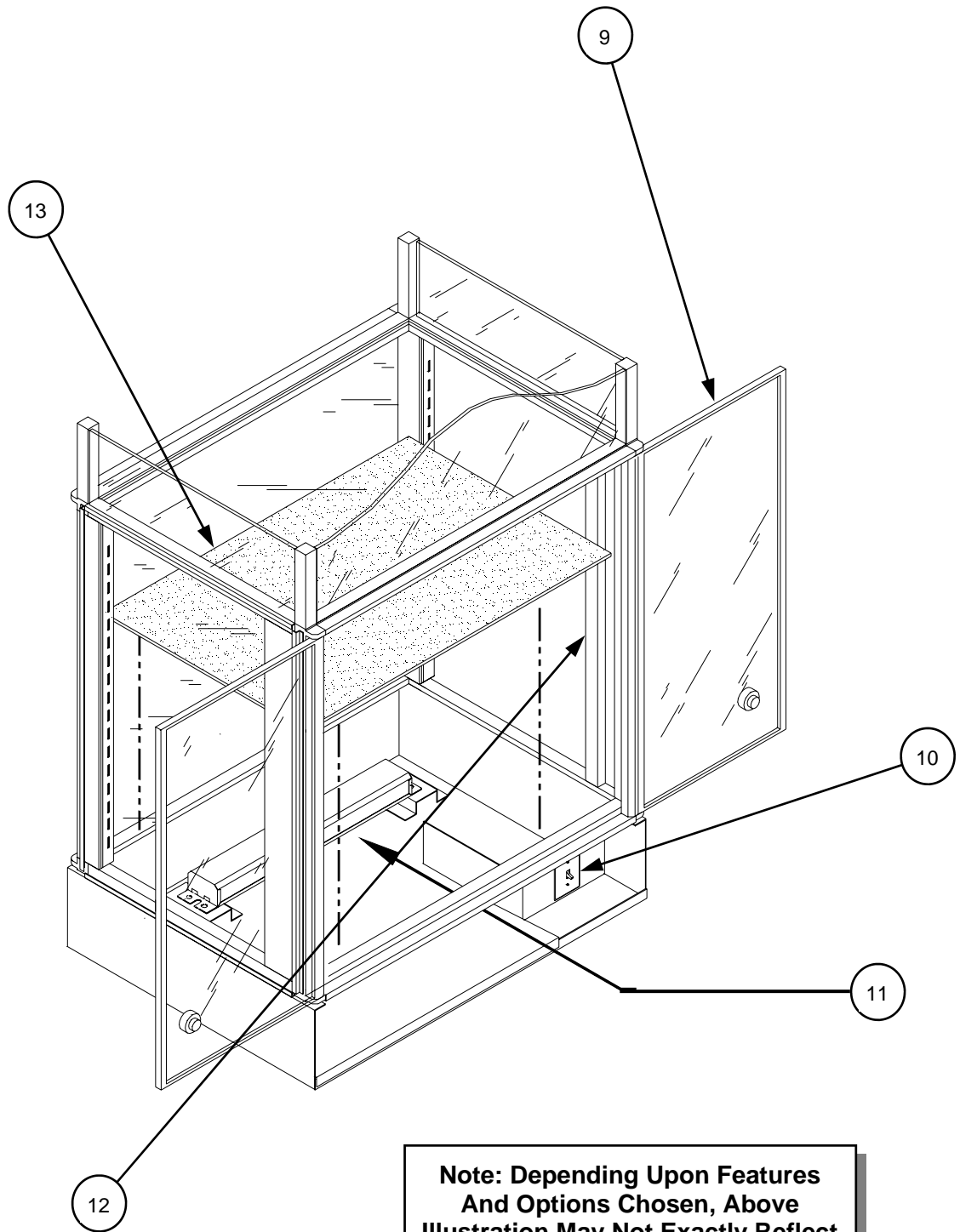

**Note: Depending Upon Features
And Options Chosen, Above
Illustration May Not Exactly Reflect
Your Particular Case.**

PARTS LIST

1	Sign Upright Tube	11	Light Ballast
2	Acrylic Sign Side	12	Light Assembly
3	Shelf Assembly	13	Deck
4	Tissue Holder	14	Shelf Support Front
5	Front Panel or Storage Door	15	Shelf Support Rear
6	Acrylic End Glass	16	Shelf Bracket
7	Top Glass	17	Bulb
8	Acrylic Sign	18	Light Socket
9	Door Assembly	19	Bulb Cover
10	Single Pole Switch		

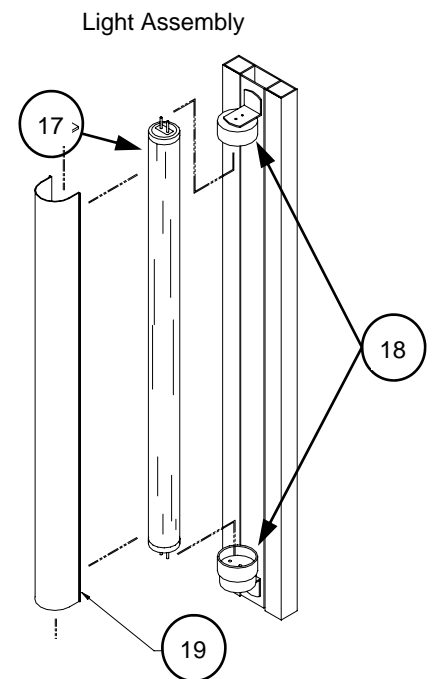
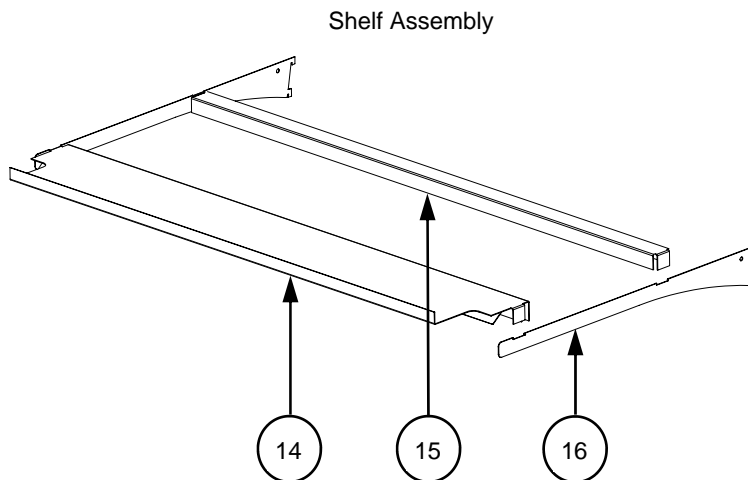

Note: Depending Upon Features And Options Chosen, Above Illustrations May Not Exactly Reflect Your Particular Case.

CLEANING SCHEDULE

Cleaning	Daily	Weekly	Monthly	Task
Clean Case Exterior	X			Clean all case exterior surfaces with a household or commercial glass cleaner and a soft cloth.
Clean Case Interior	X			Clean the interior case deck and shelving surfaces with a warm water and mild soap solution.

WARRANTY

All sales by Structural Concepts Corporation (SCC) are subject to the following limited warranty. "Goods" refers to the product or products being sold by SCC.

Warranty; Remedies; Limitations. SCC warrants that if any Goods are found by an authorized representative of SCC not to be of good material or workmanship within one year of the date of shipments SCC will, at its option after inspection by an authorized representative, replace any defective Good or pay the reasonable cost of replacement for any such defective Goods, provided that written notice of the defect is given to SCC within 30 days of the appearance of such defect. If notice is not given within such period, any claim for breach of warranty shall be conclusively deemed to have been waived and SCC shall not be liable under this warranty. If SCC is unable to repair or replace the defective Goods, SCC shall issue a credit to the Purchaser for all or part of the purchase price, as SCC shall determine. The replacement or payment in the manner described above shall be the sole and exclusive remedy of Purchaser for a breach of this warranty. If any Goods are defective or fail to conform to this warranty, SCC will furnish instructions for their disposition. No Goods shall be returned to SCC without its prior consent.

SCC's liability for any defect in the Goods shall not exceed the purchase price of the Goods. SCC SHALL HAVE NO LIABILITY TO PURCHASE FOR CONSEQUENTIAL DAMAGES OF ANY KIND WHATSOEVER, INCLUDING, BUT NOT LIMITED TO, PERSONAL INJURY, PROPERTY DAMAGE, LOST PROFITS, OR OTHER ECONOMIC INJURY DUE TO ANY DEFECT IN THE GOODS OR ANY BREACH OF SCC, SCC SHALL NOT BE LIABLE TO THE PURCHASER IN TORT FOR ANY NEGLIGENT DESIGN OR MANUFACTURE OF THE GOODS, OR FOR THE OMISSION OF ANY WARNING THEREFROM.

SCC shall have no obligation or liability under this warranty for claims arising from any other party's (including Purchaser's) negligence or misuse of the Goods or environmental conditions. This warranty does not apply to any claim or damage arising for or caused by improper storage, handling, installation, maintenance, or from fire, flood, accidents, structural defects, building settlement or movement, acts of God, or other causes beyond SCC's control.

Except as expressly stated herein, SCC makes no warranty, express, implied, statutory or otherwise as to any parts or goods not manufactured by SCC. SCC shall warrant such parts or Goods only (I) against such defects, (II) for such periods of time, and (III) with such remedies, as are expressly warranted by the manufacturer of such parts or Goods. Notwithstanding the foregoing, any warranty with respect to such parts or Goods and any remedies available as a result of a breach thereof shall be subject to all of the procedures, limitations, and exclusions set forth herein.

THE WARRANTIES HEREIN ARE IN LIEU OF ALL WARRANTIES, EXPRESS, IMPLIED, STATUTORY, OR OTHERWISE. IN PARTICULAR, SCC MAKES NO WARRANTY OF MERCHANTABILITY OR FITNESS FOR A PARTICULAR PURPOSE.

No representative, agent or dealer of SCC has authority to modify, expand, or extend this Warranty, to waive any of the limitations or exclusions, or to make any different or additional warranties with respect to Goods.

Period of Limitations. No claim, suit or other proceeding may be brought by Purchaser for any breach of the foregoing warranty or this Agreement by SCC or in any way arising out of this Agreement or relating to the Goods after one year from the date of the breach. In the interpretation of this limitation on action for a breach by SCC, it is expressly agreed that there are no warranties of future performance of the goods that would extend that period of limitation herein contained for bringing an action.

Indemnifications. Purchaser agrees to indemnify, hold harmless, and defend SCC if so requested, from any and all liabilities, as defined herein, suffered, or incurred by SCC as a result of, or in connection with, any act, omission, or use of the Goods by Purchaser, its employees or customers, or any breach of this Agreement by Purchaser. Liabilities shall include all costs, claims, damages, judgments, and expenses (including reasonable attorney fees and costs).

Remedies of SCC. SCC's rights and remedies shall be cumulative and may be exercised from time to time. In a proceeding or action relating to the breach of this Agreement by Purchaser, Purchaser shall reimburse SCC for reasonable costs and attorney's fees incurred by SCC. No waiver by SCC of any breach of Purchaser shall be effective unless in writing nor operate as a waiver of any other breach of the same term thereafter. SCC shall not lose any right because it has not exercised it in the past.

Applicable Law. This Agreement is made in Michigan and shall be governed by and interpreted according to Michigan law. Any lawsuit arising out of this Agreement or the Goods may be handled by a federal or state court whose district includes Muskegon County, Michigan, and Purchaser consents that such court shall have personal jurisdiction over Purchaser.

Miscellaneous. If any provision of this Agreement is found to be invalid or unenforceable under any law, the provision shall be ineffective to that extent and for the duration of the illegality, but the remaining provisions shall be unaffected. Purchaser shall not assign any of its rights nor delegate any of this obligations under this Agreement without prior written consent of SCC. This Agreement shall be binding upon and inure to the benefit of SCC and Purchaser and each of their legal representatives, successors and assigns.

SCC warrants its products to be free of defects in materials and workmanship under normal use and service for a period of one (1) year from the date of delivery.

This warranty is extended only to the original purchaser for use of the Goods. It does not cover normal wear parts such as plastic tongs, tong holders, tong cables, bag holders, or acrylic dividers.

General Conditions. All service labor and/or parts charges are subject to approval by SCC. Contact the Customer Service Department in writing or call 231-798-8888.

All claims must contain the following information: (1) the model and serial code number of the equipment; (2) the date and place of installation; (3) the name and address of the agency which performed the installation; (4) the date of the equipment failure; and (5) a complete description of the equipment failure and all circumstances relating to that failure.

Once the claim has been determined to be a true warranty claim by SCC's Customer Service Department, the following procedure will be taken: (1) replacement parts will be sent at no charge from SCC on a freight prepaid basis; (2) reimbursement for service labor will be paid if the following conditions have been met— (a) prior approval of service agency was awarded from the Customer Service Department; and (b) an itemized statement of all labor charges incurred is received by the Customer Service Department. The cost of the service labor reimbursement will be based on straight time rates and reasonable time for the repair of the defect.

If problems occur with any compressor, notify SCC's Customer Service Department immediately. Any attempt to repair or alter the unit without prior consent from the Customer Service Department will render any warranty claim null and void. This warranty and protection plan does not apply to any condensing unit or any part thereof which has been subject to accident, negligence, misuse, or abuse, or which has not been operated in accordance with the manufacturer's recommendations or if the serial number of the unit has been altered, defaced, or removed.

Limit of Liability. The limit of liability of SCC toward the exchange cost of the original condensing unit, F.O.B. SCC, Norton Shores, MI, of each motor-compressor assembly replaced during the warranty shall not exceed manufacturer's current established wholesaler's exchange price and in no case shall the labor of removing or replacing the motor-compressor or parts thereof be the responsibility of SCC.

**STRUCTURAL CONCEPTS CORPORATION
TECHNICAL SERVICE DEPARTMENT
1.800.433.9489**