

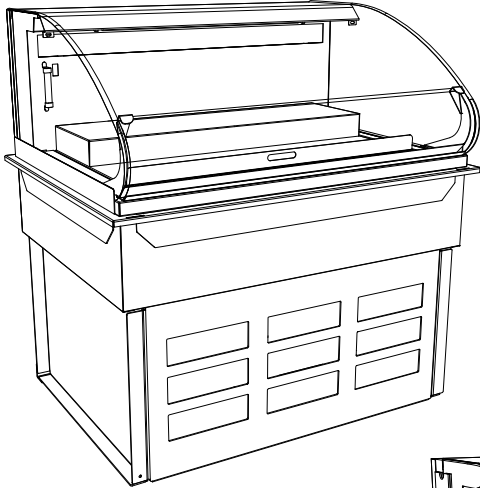

# INSTALLATION & OPERATING MANUAL

PN 54167

## SERVICE DROP-IN REFRIGERATED MERCHANDISERS



DO3616R

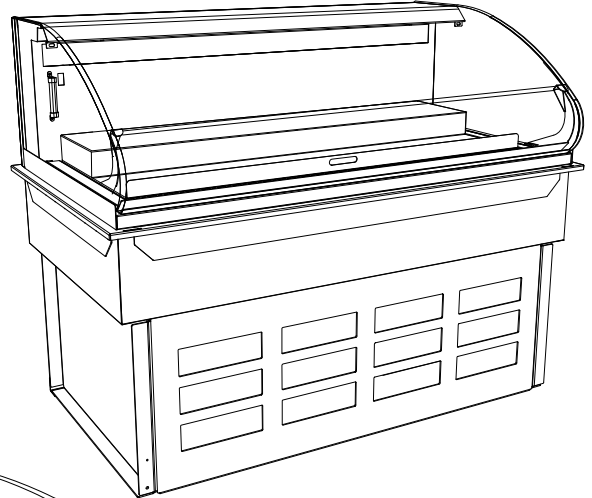

DO4816R

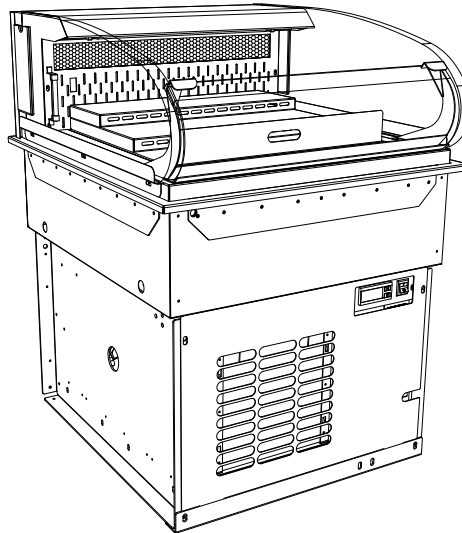

DO2412R.4909

<b>Model DO2412R.4909</b>	<b>24" L x 28 5/8" D x 12 1/4" H (Upper Display Case Only)</b>
<b>Model DO3616R</b>	<b>38 1/8" L x 28 5/8" D x 16 7/8" H (Upper Display Case Only)</b> <b>38 1/8" L x 28 5/8" D x 40 3/4" H (Upper Display Case + Drop-In Refrigeration Unit)</b>
<b>Model DO4816R</b>	<b>50 1/8" L x 28 5/8" D x 16 7/8" H (Upper Display Case Only)</b> <b>50 1/8" L x 28 5/8" D x 40 3/4" H (Upper Display Case + Drop-In Refrigeration Unit)</b>

**Note 1.** Internal counter height must be at least 28" for refrigeration and proper air flow space.

**Note 2.** *Model DO3637R & 3623R:* Service Top Cutout dimensions must be 27.15" Wide x 36.65" Long (with a minimum 1.42" perimeter) for proper clearance and fit of Drop-In Refrigerated Merchandiser. These combined dimensions require a 30" minimum counter top space for cutout.

**Note 3.** *Model DO4837R & DO23R:* Service Top Cutout dimensions must be 27.15" Wide x 48.65" Long (with a minimum 1.42" perimeter) for proper clearance and fit of Drop-In Refrigerated Merchandiser. These combined dimensions require a 30" minimum counter top space for cutout.



888 E. Porter Road · Muskegon, MI 49441 Phone: 231.798.8888 Fax: 231.798.4960 www.structuralconcepts.com

## TABLE OF CONTENTS

OVERVIEW AND WARNINGS .....	3
CUSTOMER CABINET PROVISIONS.....	4
CLEARANCE AND AIR FLOW .....	5
VENTING INSTRUCTIONS FOR AIR INTAKE / EXHAUST - DO3616R / DO4816R.....	6
INSTALLATION .....	7
START-UP AND OPERATION .....	8
MAINTENANCE FUNDAMENTALS .....	9-10
REFRIGERATION FUNDAMENTALS .....	11
REFRIGERATION SLIDE-OUT EXPLODED PICTORIAL .....	12
SERIAL LABEL LOCATION & INFORMATION LISTED / TECH INFO & SERVICE.....	13
TROUBLESHOOTING .....	14-15
CLEANING SCHEDULE .....	16
CAREL® TEMPERATURE CONTROLLER INFORMATION .....	17-19
TECHNICAL SERVICE CONTACT INFORMATION & WARRANTY INFORMATION .....	20

## OVERVIEW AND WARNINGS

### OVERVIEW

- These Structural Concepts® refrigerated self-service cases are designed to merchandise packaged products at 5° Celsius / 41° Fahrenheit or less product temperatures.
- These cases should be installed and operated according to the following instructions to insure proper performance.
- This unit is designed for the display of products in ambient store conditions where temperatures and humidity are maintained at a maximum of 24°C / 75°F and 55% relative humidity.



**WARNING**  
Risk of Electric Shock.  
Disconnect Power Before Servicing Unit



**WARNING**  
Hazardous Moving Parts.  
Do Not Operate unit with covers removed.  
Fan blades may be exposed when deck panel is removed. Disconnect  
power before removing deck panel.



**WARNING**  
Evaporator Tray is Hot



**CAUTION**  
Lamps have been treated to resist breakage and must be replaced with a  
similarly treated lamp.

## CUSTOMER CABINET PROVISIONS

### Customer Cabinet Provisions

- Customer provided cabinet must adhere to the minimum requirements in ANSI/UL Std. 471 and ANSI/NSF Std. 7.
- Among the factors that are to be taken into consideration when judging the acceptability of a cabinet or similar enclosure are mechanical strength, resistance to impact, moisture-absorptive properties, flame resistance, resistance to distortion at temperatures to which the material may be subjected under conditions of use, and resistance to corrosion.
- Customer provided cabinet or similar enclosure shall have the strength and rigidity necessary to resist conditions of intended use without increasing the risk of fire or injury to persons due to total or partial collapse. Cabinet or similar enclosure must be strong enough to hold weight of cabinet and intended product load. Dry weight (no product in case) exceeds 500 pounds.
- A nonmetallic cabinet or similar enclosure (or part of an enclosure) shall have a flame spread index of not more than 200 when tested in accordance with the Standard for Tests for Surface Burning Characteristics of Building Materials, UL 723.
- The cabinet or similar enclosure shall be constructed and assembled to reduce the risk of fire due to the emission of molten metal, burning insulation, flaming particles, or the like, through openings onto flammable material, including the surface over which the refrigeration is mounted.
- A sheet metal cabinet or similar enclosure is to be judged for acceptability with respect to its size, shape, metal thickness. Sheet metal such as galvanized or stainless shall be 0.30 inch (22 gage) or greater.
- Steel enclosures shall be protected against corrosion by metallic or nonmetallic coatings, such as plating or painting.
- The refrigeration access panel/door shall be arranged so that main power switch, refrigeration controller and refrigeration package are accessible without removing parts other than access panel/door.
- A hinged or pivoted panel shall be positioned or arranged so that when it is in an open position falling or swinging due to gravity or vibration will not cause injury to persons.
- For electrical protection when installed in its intended manner, louvers and other openings in the enclosure shall be constructed and located to reduce the risk of unintentional contact with moving, live or hot parts such as fan blades and condensate trays. The minor dimension of such openings shall not exceed 3 inches—See Table 6.1 for Clearance from Openings. Tools are required to remove covers, panels or grilles unless interlock is provided.
- Ventilation openings/louvers shall be free of sharp edges and burrs and have spaces large enough to allow for easy cleaning. Louvers that may be subject to splashes, spills, and overhead drips shall be of a drip-deflecting design.

**Table 6.1**  
Clearance from openings

Minor dimension of opening <sup>a,d</sup>		Minimum distance from opening to moving part <sup>c</sup>	
inches	(mm)	inches	(mm)
1/4	6.4	3/8	9.5
3/8	9.5	1-1/4	31.8
1/2	12.7	2	50.8
3/4	19.1	3-5/8	92.1
1	25.4	5-1/4	133.4
1-1/2	38.1	8-3/8	212.7
2	50.8	11-5/8	295.3
Over 2 <sup>b</sup>	Over 50.8	30	762.0

<sup>a</sup> Openings less than 1/4 inch (6.4 mm) are not to be considered.

<sup>b</sup> But not more than 3 inches (76.2 mm). See 6.3.9.

<sup>c</sup> Also applies to hot parts. See 6.3.11 and 6.3.12.

<sup>d</sup> For fan blade guards that have openings with minor dimensions less than 1 inch, see 6.3.8.

**Service Top Cutout Dimensions**

Note: See Manual Cover for Service Top Cutout Dimensions.

**Clearance Dimensions**

The Refrigerated section must maintain airflow clearance. Dimensions are as follow.

1. 4" Minimum Spacing from bottom of refrigeration frame to bottom of cabinet or floor required for adequate air flow.
2. 9 1/2" Countertop / Facia enclosure space on cabinets or counter to allow for pullout system slide-out.
3. 15" Minimum opening in back of cabinet or counter (to pull out refrigeration system).
4. Back of counter / cabinet must be vented at specific sizes to allow for proper air intake and air exhaust. See Venting Instructions sections for specifics.
5. Front of counter ventilation must be at least (2") to allow proper air intake and exhaust. See illustration at right.
6. Obstruction or restriction of air can void warranty.

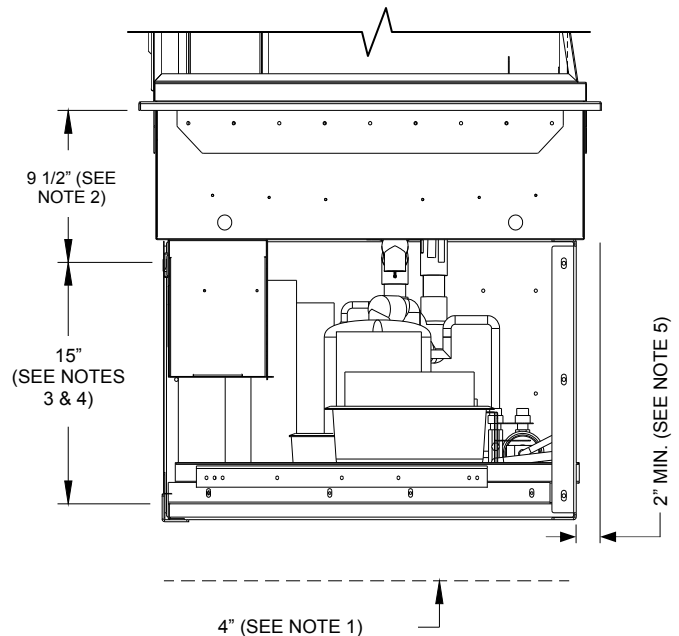

4" (SEE NOTE 1)

ABOVE ILLUSTRATION APPLIES TO BOTH MODELS

**Note: See Venting Instructions sections (next page) for more specific Air Intake and Air Exhaust clearance dimensions.**

**ILLUSTRATION BELOW REFLECTS REAR VIEW OF CABINET AFTER POSITIONED ON CUSTOMER-SUPPLIED COUNTER/BASE**

***WARNING!: The MINIMUM intake and exhaust areas must be allowed (as illustrated below) or case temperatures may fluctuate beyond safe parameters!***

**NOTES:**

1. THE IDEAL CONDITION FOR REAR OF CABINET IS TO HAVE COMPLETE OPEN SPACE (WITH NO DOORS OR BLOCKING OF AIRFLOW WHATSOEVER).
2. SHOULD CABINET DOORS BE DESIRED (AS SHOWN BELOW) LOUVERS (or SCREENING) MUST BE PROVIDED.
  - LOUVERS (or SCREENING) MUST BE 2" OR CLOSER TO EACH OTHER VERTICALLY.
  - LOUVER (or SCREENING) MUST EXTEND AT LEAST 4" BEYOND EACH END OF REFRIGERATION UNIT.
  - THIS SHEET REFLECTS THE MINIMUM REQUIRED VENTILATION. ADDITIONAL VENTILATION IS RECOMMENDED AND WILL HELP MAINTAIN ACCEPTABLE MERCHANDISING TEMPERATURES.
3. SEE REFRIGERATION FUNDAMENTALS FOR VIEW OF CONDENSING UNIT AFTER SLIDE-OUT.
4. UNITS WITH REAR REFRIGERATION PACKAGE SLIDE-OUT (AS SHOWN BELOW) MUST MAINTAIN AT LEAST A 3-FOOT SPACE BETWEEN REAR OF CABINET AND WALL TO ALLOW FOR SERVICE.
5. UNITS WITH FRONT REFRIGERATION PACKAGE SLIDE-OUT CAN HAVE REAR OF CABINET FLUSH TO WALL, IF DESIRED.

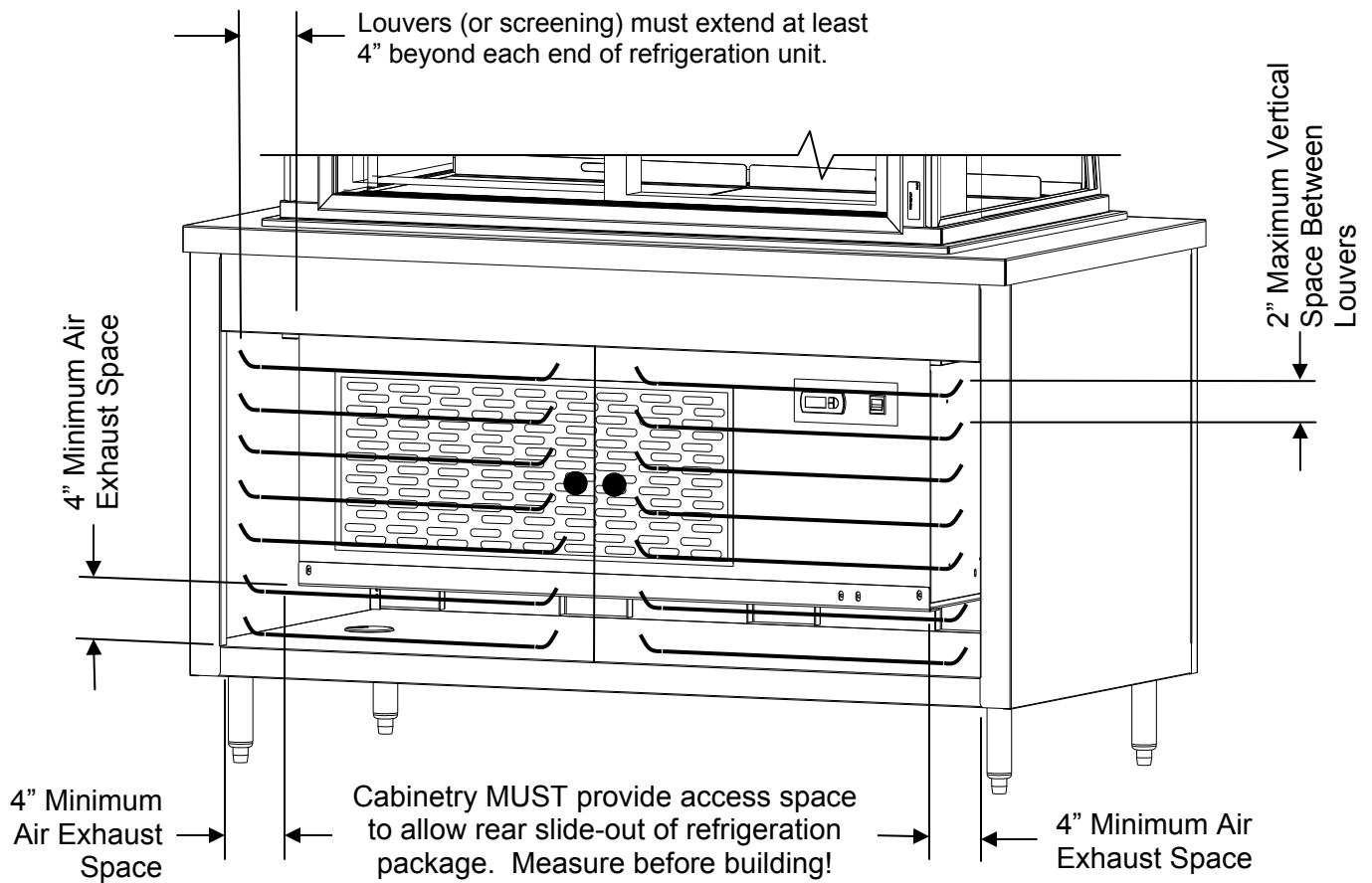

## INSTALLATION

### 1. Remove Case From Skid

Caution: Case must always remain supported or center of gravity may allow case to fall. Slide to rear of skid and tip backward off skid while maintaining support.

Note: Illustration below may not exact reflect every feature or option of your particular case.

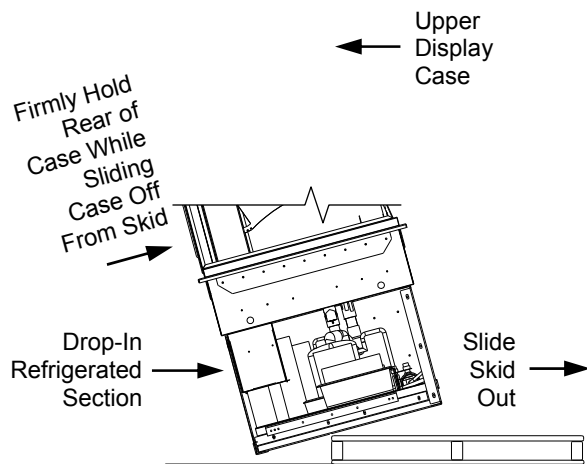

### 2. Display Case Setup

- SCC® Service Drop-In Refrigerated Merchandiser Case consists of two sections: The Upper Display Case and Drop-In Refrigerated Section.
- As both sections make up one conjoined unit, it is both large and heavy. A team effort is required for lowering Case into the Customer Supplied Base.
- After lowering into Base, adjust into position allowing Case to gingerly rest on Counter Top without marring.

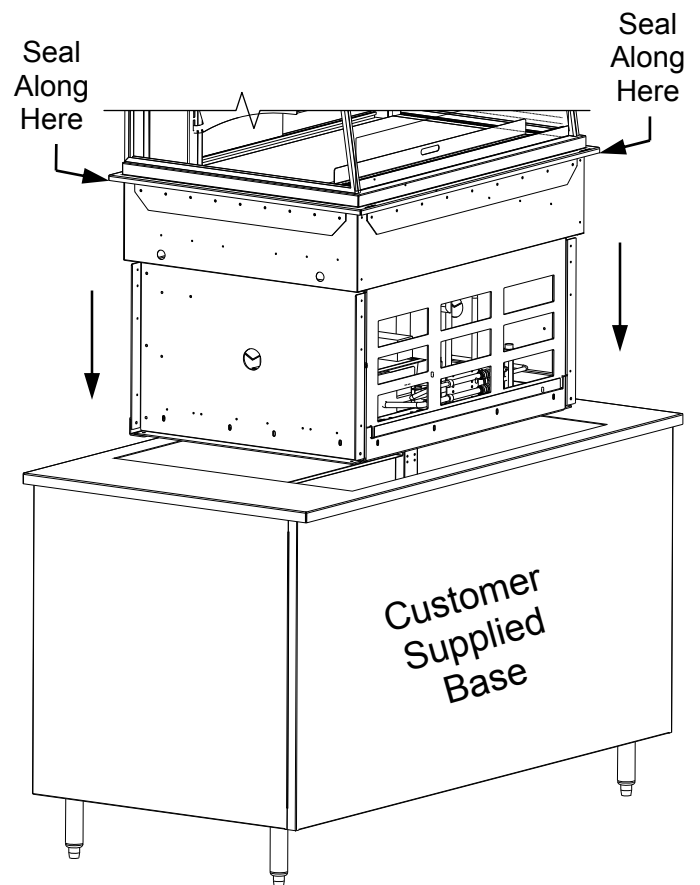

### 3. Seal Upper Display Case to Base

- NSF® Listed Industrial Grade Silicone Sealant is recommended.
- Clip tip to allow approximately 1/8" to 3/16" diameter hole.
- Beginning at case rear, run a consistent, solid bead of silicone around entire perimeter.



## START-UP AND OPERATION

### Case Start-Up

- Plug cord into a certified electrical outlet with ground.
- Turn on the Main Power Switch. Switch is in the Drop-In Refrigerated Section on the rear right hand side of base (see illustration at top right).
- The Temperature Control Module (LED) will illuminate. Evaporator coil fans and the compressor motor should turn on.
- From the front of the case, raise the deck to confirm that the coil fans are functioning properly.
- Turn on the lights. Light Switch is in the Upper Display interior of the case right next to thermometer (see illustration at mid-right).
- First time lighting may require a short warm up period for the bulbs. Slightly dim or a flickering of new bulbs is normal.

### Temperature Settings

- This case has been tested to maintain a temperature at or below 5°C / 41°F.
- When the merchandiser is in a start up mode or has been idle for a long period of time, the unit will require 30 minutes in order to pull-down to temperature.
- Spirit-Filled Thermometer located in refrigerated compartment is for monitoring warmest air temperature in accordance with NSF® Std. 7 (see illustration at right).
- The temperature is controlled by a Temperature Control Module. It is located at the lower-right area (from the case rear) of the Drop-In Refrigerated Section. See top-right illustration for general location.
- If a temperature setting change is required, refer to the instructions in the Temperature Controller section of this manual

### Light Ballast Access

- Light ballast is located inside the Electrical J-Box. Electrical J-Box is located at lower-right side (from the rear) of the Drop-In Refrigerated Section.
- See illustration at top right for general location.

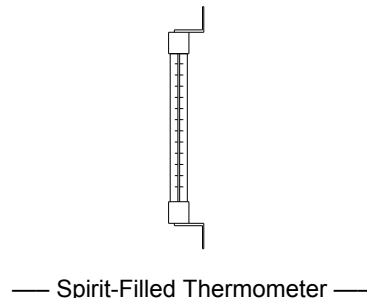
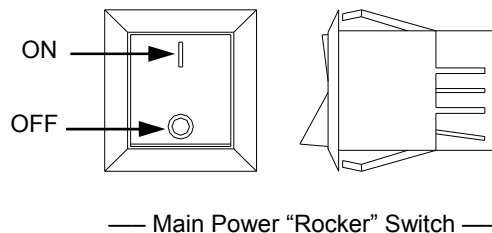
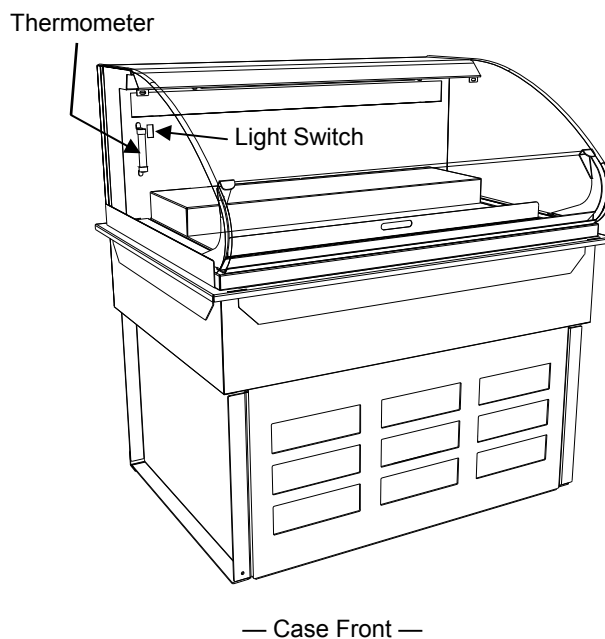
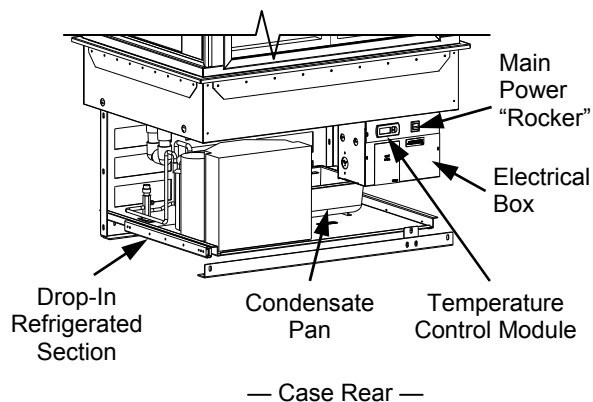

### **Light Fixture**

Removal of lamp:

- Rotate lamp (1/4 turn) so that pins are aligned in slots and remove bulb.

Installation of lamp:

- Align pins with slot.
- Insert pins into socket and rotate 1/4 turn to secure pin contacts in socket.
- See illustration below.

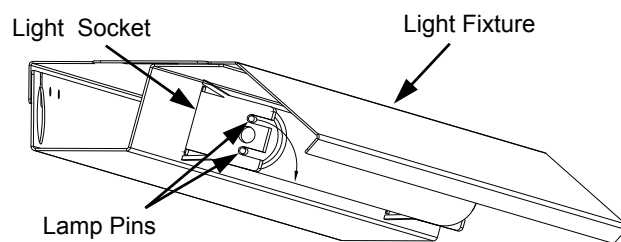

**Warning, disconnect power before providing maintenance and service to unit. Assembly or disassembly and servicing is to be accomplished by licensed electrical contractor.**

**Evaporator Coil Fans Access and Removal**

- Fans may be accessed by removing Deck (covering Fan Shroud, Fan Housing and Coil). See illustrations at right.

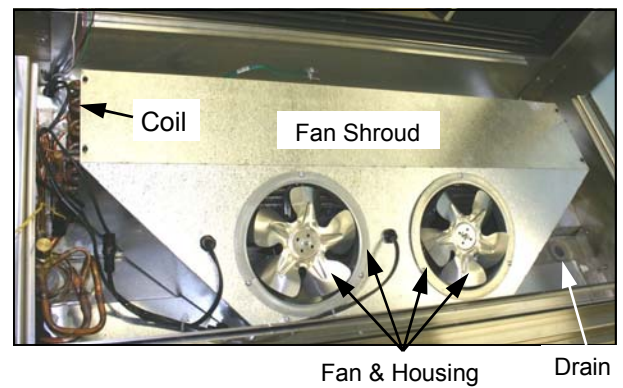
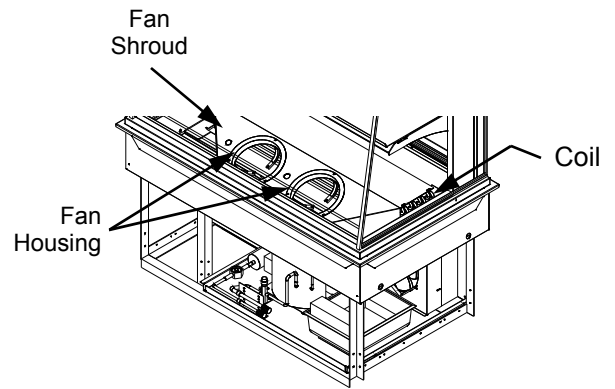

## Refrigeration Access, Connections & Servicing

### Access to condenser coil for cleaning.

- No tools required!
- Access to Refrigeration Unit (for cleaning condenser coil) is possible without tools.
- Remove the (2) Thumb Screws on Rear Grille.
- Flip down Rear Grille. Lift grille up and out (with Tabs clearing the Base Frame Angle).
- Be careful NOT to misplace Thumb Screws!
- Cleaning of Condenser Coil can be done without sliding out Refrigeration Unit.
- See Cleaning Schedule for cleaning guidelines.
- Replace Rear Grille in reverse order it was removed (with Tabs behind Base Frame Angle).
- See illustration at right.

### Assembly or disassembly and servicing to be accomplished by licensed refrigeration contractor.

- Refrigeration Unit slides directly out from lower section to allow for servicing.
- Service connections are located in the Refrigeration Slide-Out (shown at right).
- Evaporator Pan is provided for case condensation. Insure evaporator pan is plugged in 110V receptacle inside base, and positioned under PVC drain and on base frame.
- When pulling or pushing unit in or out under the case, use caution to avoid damage to copper refrigeration lines, hoses and cable.
- Insure that the flexible drain hose is fully inserted into the slot of hose support for proper drainage. See illustration on next page for general location and specifics.

### Temperature Control Module

- Temperature Control Module is located in the Electrical J-Box.
- The temperature is controlled by the Temperature Control Module. It is located at lower-right area (from the rear) of the Drop-In Refrigerated Section. See top-right illustration for general location.
- If a temperature setting change is required, refer to the Temperature Controller instructions in this manual.

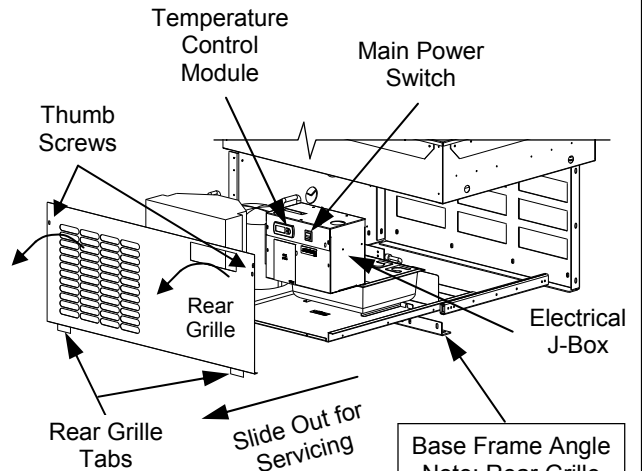

Base Frame Angle  
Note: Rear Grille Tabs must be behind Base Frame Angle for proper attachment.

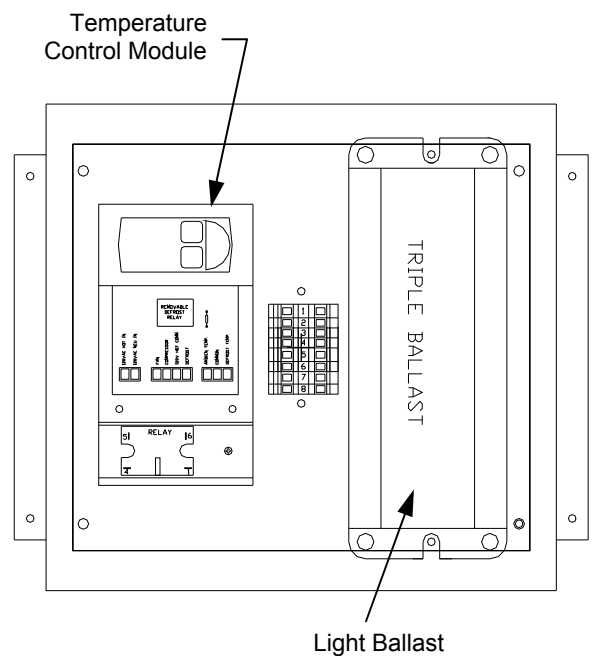

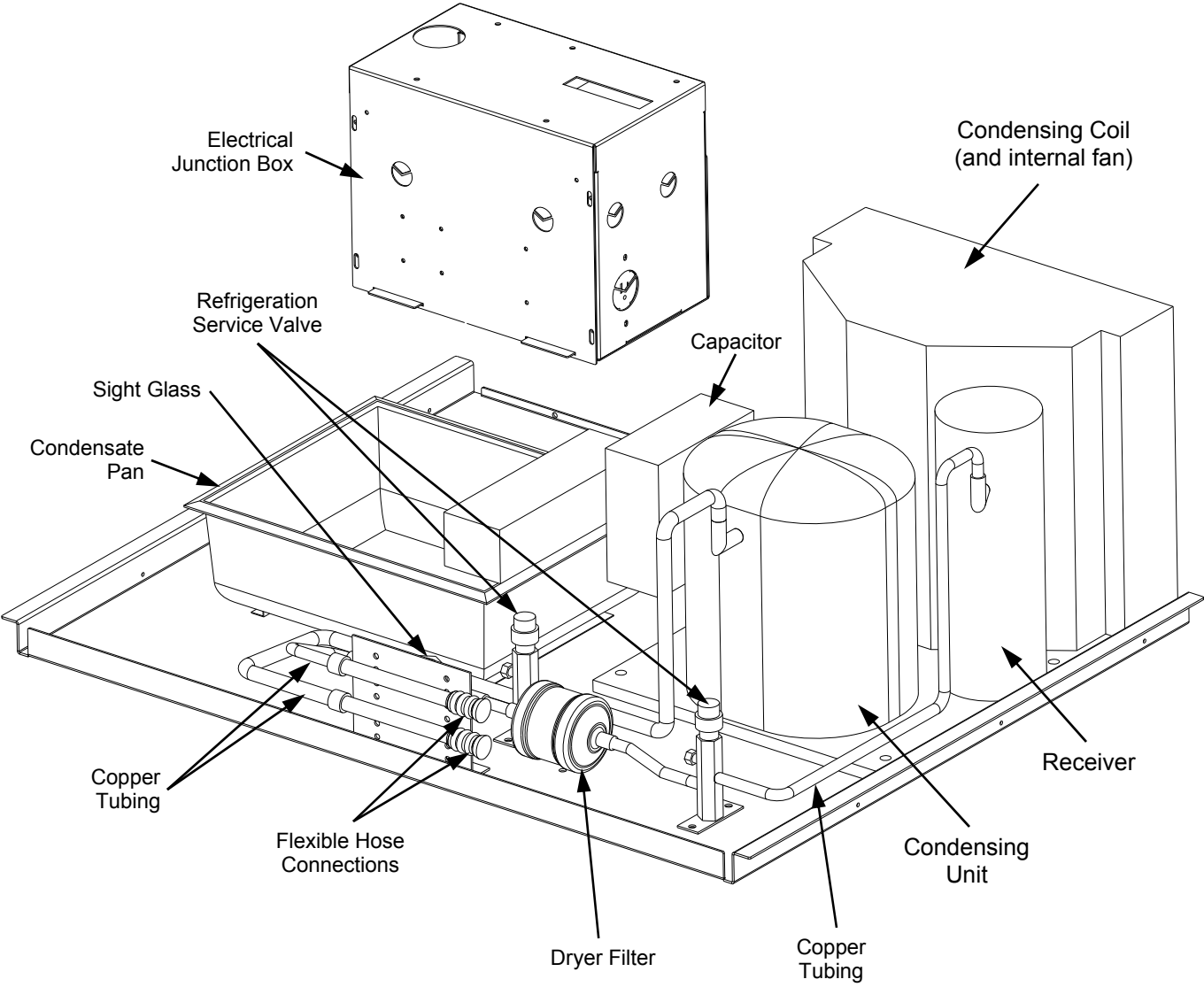

# REFRIGERATION SLIDE-OUT EXPLODED PICTORIAL

The following images show the various parts pertaining to the Refrigeration Unit (that is slid directly out from lower section) to be serviced.





**Serial Label Location & Information Listed / Technical Information & Service**

- Serial labels are located near the electrical access on your case.
- Serial labels contain electrical, temperature & refrigeration information, as well as regulatory standards to which the case conforms.
- For additional technical information and service, see the *TECHNICAL SERVICE* page in this manual for instructions on contacting Structural Concepts' Technical Service Department.
- See images below for samples of both refrigerated and non-refrigerated serial labels.

 <p>888 E. Porter Rd · Muskegon, MI 49441</p>		 <p>MODEL HV74RSS SCROLL SERIAL NO.</p>	
<p><b>FOR PARTS AND SERVICE</b> CALL 1-800-433-9489</p>			
 <p>3048256</p> <p>CONFORMS TO UL STD 471 CONFORMS TO NSF STD 7 CERTIFIED TO CAN/CSA STD C22.2 NO 120</p>		<p>ELECTRICAL RATING                      120/1/60 24A REFRIGERANT                                R404A AMOUNT ?? OZ DESIGN PRESSURE                         HIGH 450 LOW 200 MINIMUM CIRCUIT                         30A MAXIMUM OVERCURRENT                30A</p>	
Super Heat Temp	8-10°F		
BTUH Requirements	9,738 BTUH @ 20° F SST		
Defrost	6 defrosts per day, 45° F termination, 45 min. failsafe		

----- Sample Serial Label For Refrigerated Case -----

 <p>888 E. Porter Rd · Muskegon, MI 49441</p>		 <p>PC5682                      txtRemote txtSerialNumber</p>	
 <p>3048256</p> <p>CONFORMS TO UL STD 65 CERTIFIED TO CAN/CSA STD C22.2 NO 120</p>		<p>120 VOLTS      60 HZ      SINGLE PHASE      1.84AMP</p> <p>FOR PARTS OR SERVICE CALL STRUCTURAL CONCEPTS AT 1-800-433-9489</p>	
			SAMPLE ONLY

----- Sample Serial Label For Non-Refrigerated Case -----

## TROUBLESHOOTING

<b>Product is Drying Out</b>	Check the relative humidity in the store.
<b>Water on the Floor</b>	Check that all of the hoses are connected.
	Check that the drain trap is free of debris.
<b>Excessive Fan Noise</b>	Check that the case is aligned properly.
	Check that nothing is obstructing the blade rotation.
	Check that the fan shroud is properly secured.
<b>System is not Operating</b>	Confirm the utility power is on.
	Check that the MAIN power switch is on.
	Check that the unit is properly plugged in.
	Check the circuit breaker box for tripped circuits.
<b>Fans Not Working</b>	Check that the MAIN power switch is on.
	Determine if there is ice build up blocking the fan.
<b>Case Lights Not Working</b>	Check bulbs for proper installation and connection.
	Check for burned out bulbs.
	Clean dirt and dust from the bulbs to prevent flickering.
<b>Condensing Unit Not Operating</b>	See Temperature Controller section of this manual for information on your particular controller's troubleshooting instructions.
	Check that the power is turned on.
	Review factory time settings on the temperature controller.

## TROUBLESHOOTING, CONTINUED

<b>Alarm Going Off</b>	See Temperature Controller section of this manual for information on your particular controller's troubleshooting instructions.
<b>Not Holding Temperature</b>	If a large amount of warm product was added to the case, it will take time for the temperature to adjust.
	The temperature will change during defrost mode but will return to normal.
	Check that the discharge air is not disrupted or blocked by product (Product is above load limit level).
	Check that the case is not in the sun or near a heat or air-conditioning vent.
	Is case located near front doors? Wide ranging temperature fluctuation can occur if inside temperatures widely vary from outside temperatures.
	Check the evaporator coil for ice build up (can be viewed from fan shroud inspection cover).

## CLEANING SCHEDULE

Cleaning	Daily	Weekly	Monthly	Task
Clean Case Exterior	X			Clean outside surface of front curved glass with a household or commercial glass cleaner.
	X			Clean wood, laminate and painted surfaces with a mild soap and water solution and a soft cloth .
			X	Remove rear panel. Clean under case with vacuum.
Clean Case Interior	X			Shelves may be cleaned with a household or commercial glass cleaner.
		X		Remove the decks and clean with soap and water.
		X		Remove rear doors and clean with a household or commercial cleaner
		X		Vacuum tub under deck if necessary. To flush out the tub, disconnect power to the case. Remove the deck and the fan shroud. Direct drain to floor drain or a bucket. Run hose into the drain to flush out debris. Hose out the tub.
		X		Keep drains clean and free of debris which could clog the drain and rob the case of needed refrigeration.
			X	<p>Clean the dust and dirt that collects on the condenser coil.</p> <ul style="list-style-type: none"> <li>• Flip down rear grille (by removing the two thumb screws at top).</li> <li>• Lift grille up and out (with tabs clearing the Base Frame Angle).</li> <li>• Using an industrial strength vacuum (and attached brush), carefully clean condenser coil.</li> <li>• Caution! Be careful not to damage the fins on the coil.)</li> <li>• Replace Rear Grille in reverse order it was removed (with Tabs behind Base Frame Angle).</li> <li>• Reattach thumb screws to top of Rear Grille.</li> <li>• See Refrigeration Fundamentals section</li> </ul>
			X	Slide out Refrigeration Unit. Use vacuum with a hose attachment to clean area.

# CAREL

**ir33 platform**  
Integrated Electronic  
Microprocessor Controller



## Programming The Instrument

### How To Modify The Setpoint

**Set** Press and hold the "SET" key for at least 1 second.

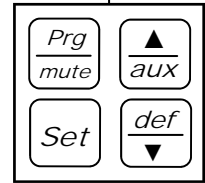

### How To Modify The Defrost, Differential Or Other Parameters

**Prg/mute** **Set** 1. Press & hold "Prg" and "SET" keys together for at least 5 seconds; the display will show the number "0", representing the password prompt.

**Set** 2. Confirm by pressing "SET" key.

**▲/aux** **def** 3. Press ▲ or ▼ to reach the category to be modified.

**Set** 4. Press "SET" to modify this selected parameter.

**▲/aux** **def** 5. Increase or decrease the value using the ▲ or ▼ button respectively.

**Set** 6. Press the "SET" key to temporarily save the new value and return to the display of the parameter.

**Prg/mute** 7. Press & hold the "Prg" key for at least 5 seconds to save changes. This action will also mute the audible alarm (buzzer) & deactivate the alarm relay.

### How To Change Reading From Fahrenheit (°F) To Celsius (°C)

**Prg/mute** **Set** 1. Press and hold "Prg" and "SET" keys together for at least 5 seconds; display will show "0", representing password prompt.

**Set** 2. Confirm by pressing "SET" key.

**▲/aux** **def** 3. Press ▲ or ▼ until reaching the parameter "/ 5".

**Set** 4. Press "SET" to modify this selected parameter.

**▲/aux** **def** 5. Press ▲ or ▼ to change value to desired setting: "0" for Celsius (°C) or "1" for Fahrenheit (°F).

**Set** 6. Press "SET" key to temporarily save the new value and return to the display of the parameter.

**Prg/mute** 7. Press & hold "Prg" key for at least 5 seconds to save changes. **Note! All values will automatically convert to new scale. No conversion is required.**

### Warning! Save Your Parameter Settings!

1. To store the new parameter values, PRESS and HOLD the "Prg" key for at least 5 seconds.
2. All modifications made to parameters will be lost if you do NOT press a button within 60 seconds. Should this "timeout" occur, normal operational settings (prior to modifications being made) will resume.
3. If the instrument is switched off before pressing the "Prg" key, all modifications to parameters will be lost.

### How To Activate Manual Defrost

**def** Press and hold the "def" key for at least 5 seconds.

### How To Activate / Deactivate Auxiliary Output

**▲/aux** Press and hold the "aux" key for at least 1 second.

### How To Reset Any Alarms With Manual Reset

**Prg/mute** **▲/aux** Press and hold the "Prg" and "aux" key for at least 1 second.

# CAREL

**ir33 platform**  
**Integrated Electronic  
 Microprocessor Controller**



## User Interface - Display

ICON	FUNCTION	DESCRIPTION	ON	Normal operation OFF	BLINK	Start up
	COMPRESSOR	ON when the compressor starts. Flashes when the activation of the compressor is delayed by safety times.	Compressor on	Compressor off	awaiting activation	
	FAN	ON when the fan starts. Flashes when the activation of the fan is prevented due to external disabling or procedures in progress.	Fan on	Fan off	awaiting activation	
	DEFROST	ON when the defrost is activated. Flashes when the activation of the defrost is prevented due to external disabling or procedures in progress.	Defrost in progress	Defrost not in progress	awaiting activation	
	AUX	Flashes if the anti-sweat heater function is active, ON when the auxiliary output (1 and/or 2) selected as AUX (or LIGHT in firmware version 3.6) is activated.	AUX auxiliary output active (version 3.6 light auxiliary output active)	AUX auxiliary output not active	Anti-sweat heater function active	
	ALARM	ON following pre-activation of the delayed external digital input alarm. Flashes in the event of alarms during normal operation (e.g. high/low temperature) or in the event of alarms from an immediate or delayed external digital input.	Delayed external alarm (before the time 'A7' elapses)	No alarm present	Alarms in norm. operation (e.g. High/low temperature) or immediate or delayed alarm from external digital input	
	CLOCK	ON if at least one timed defrost has been set. At start-up, comes ON for a few seconds to indicate that the Real Time Clock is fitted.	If at least 1 timed defrost event has been set	No timed defrost event set	Alarm clock	ON if real-time clock present
	LIGHT	Flashes if the anti-sweat heater function is active, ON when the auxiliary output (1 and/or 2) selected as LIGHT is activated (in firmware version 3.6 it does not flash in anti-sweat heater mode and comes on when the dead band output is active).	Light auxiliary output on (version 3.6 dead band auxiliary output active)	Light auxiliary output off	Anti-sweat heater function active (version 3.6 does not flash in anti-sweat heater mode)	
	SERVICE	Flashes in the event of malfunctions, for example E2PROM errors or probe faults.		No malfunction	Malfunction (e.g. E2PROM error or probe fault). Contact service	
	CONTINUOUS CYCLE	ON when the CONTINUOUS CYCLE function is activated. Flashes if the activation of the function is prevented due to external disabling or procedures in progress (E.g.: minimum compressor OFF time).	CONTINUOUS CYCLE operation activated	CONTINUOUS CYCLE function not activated	CONTINUOUS CYCLE operation requested	

## Summary Table of Alarm and Signals: Display, Buzzer and Relay

Code	Icon on the display	Alarm relay	Buzzer	Reset	Description
rE	flashing	on	on	automatic	virtual control probe fault
E0	flashing	off	off	automatic	room probe S1 fault
E1	flashing	off	off	automatic	defrost probe S2 fault
E2	flashing	off	off	automatic	probe S3 fault
E3	flashing	off	off	automatic	probe S4 fault
E4	flashing	off	off	automatic	probe S5 fault
'	No	off	off	automatic	probe not enabled
LO	flashing	on	on	automatic	low temperature alarm
HI	flashing	on	on	automatic	high temperature alarm
AFr	flashing	on	on	manual	antifreeze alarm
IA	flashing	on	on	automatic	immediate alarm from external contact
dA	flashing	on	on	automatic	delayed alarm from external contact
dEF	on	off	off	automatic	defrost running
Ed1	No	off	off	automatic/manual	defrost on evaporator 1 ended by timeout
Ed2	No	off	off	automatic/manual	defrost on evaporator 2 ended by timeout
Pd	flashing	on	on	automatic/manual	maximum pump down time alarm
LP	flashing	on	on	automatic/manual	low pressure alarm
AtS	flashing	on	on	automatic/manual	autostart in pump down
cht	No	off	off	automatic/manual	high condenser temperature pre-alarm
CHT	flashing	on	on	manual	high condenser temperature alarm
dor	flashing	on	on	automatic	door open too long alarm
EE	flashing	off	off	automatic	E2prom error, unit parameters
EF	flashing	off	off	automatic	E2prom error, operating parameters
ccb	Signal				start continuous cycle request
ccE	Signal				end continuous cycle request
dFb	Signal				start defrost call
dFE	Signal				end defrost call
On	Signal				switch ON
off	Signal				switch OFF
rES	Signal				reset alarms w/manual reset / reset HACCP alarms / reset temp. monitoring

# CAREL

**ir33 platform**  
 Integrated Electronic  
 Microprocessor Controller



## Summary Table of Operating Parameters

CODE	PARAMETER	UOM*	TYPE	MINIMUM	MAXIMUM	DEFAULT
/5	Select Celsius (°C) or Fahrenheit (°F)	flag	C	0	1	For Case Specific Defaults See Serial Label Located Near Electrical Access On Your Case.  For Additional Technical Information Call Structural Concepts Technical Service Dept. at 1(800) 433.9489
/c1	Calibration of probe 1	°C/°F	C	-20	20	
/c2	Calibration of probe 2	°C/°F	C	-20	20	
St	Temperature set point	°C/°F	F	r2	r1	
rd	Control delta	°C/°F	F	20	0.1	
dl	Interval between defrosts	hours	F	0	250	
dt1	End defrost temperature, evaporator	°C/°F	F	-50	200	
dP1	Maximum defrost duration, evaporator	min	F	1	250	
d6	Display on hold during defrost	-	C	0	2	
dd	Dripping time after defrost	min	F	0	15	
d/1	Display of defrost probe 1	°C/°F	F	-	-	

\* Unit Of Measure

STRUCTURAL CONCEPTS CORPORATION TECHNICAL SERVICE  
PHONE NUMBER: 1.800.433.9489 or For Your Master Service Agent See  
WWW.STRUCTURALCONCEPTS.COM/Contact/Master\_Service\_Agents.asp

## WARRANTY INFORMATION

**(Note: Standard Limited Warranty can be found at [www.Structuralconcepts.com](http://www.Structuralconcepts.com))**

All sales by Structural Concepts Corporation (SCC) are subject to the following limited warranty. "Goods" refers to the product or products being sold by SCC.

**Warranty Scope:** Warranty is for equipment sold in the United States, Canada, Mexico and Puerto Rico. Equipment sold elsewhere may carry modified warranty.

**Warranty; Remedies; Limitations.** SCC warrants that if any Goods are found by an authorized representative of SCC not to be of good material or workmanship within one year of the date of shipments SCC will, at its option after inspection by an authorized representative, replace any defective Good or pay the reasonable cost of replacement for any such defective Goods, provided that written notice of the defect is given to SCC within 30 days of the appearance of such defect. If notice is not given within such period, any claim for breach of warranty shall be conclusively deemed to have been waived and SCC shall not be liable under this warranty. If SCC is unable to repair or replace the defective Goods, SCC shall issue a credit to the Purchaser for all or part of the purchase price, as SCC shall determine. The replacement or payment in the manner described above shall be the sole and exclusive remedy of Purchaser for a breach of this warranty. If any Goods are defective or fail to conform to this warranty, SCC will furnish instructions for their disposition. No Goods shall be returned to SCC without its prior consent.

SCC's liability for any defect in the Goods shall not exceed the purchase price of the Goods. SCC SHALL HAVE NO LIABILITY TO PURCHASE FOR CONSEQUENTIAL DAMAGES OF ANY KIND WHATSOEVER, INCLUDING, BUT NOT LIMITED TO, PERSONAL INJURY, PROPERTY DAMAGE, LOST PROFITS, OR OTHER ECONOMIC INJURY DUE TO ANY DEFECT IN THE GOODS OR ANY BREACH OF SCC. SCC SHALL NOT BE LIABLE TO THE PURCHASER IN TORT FOR ANY NEGLIGENT DESIGN OR MANUFACTURE OF THE GOODS, OR FOR THE OMISSION OF ANY WARNING THEREFROM.

SCC shall have no obligation or liability under this warranty for claims arising from any other party's (including Purchaser's) negligence or misuse of the Goods or environmental conditions. This warranty does not apply to any claim or damage arising for or cause by improper storage, handling, installation, maintenance, or from fire, flood, accidents, structural defects, building settlement or movement, acts of God, or other causes beyond SCC's control.

Except as expressly stated herein, SCC makes no warranty, express, implied, statutory or otherwise as to any parts or goods not manufactured by SCC. SCC shall warrant such parts or Goods only (I) against such defects, (II) for such periods of time, and (III) with such remedies, as are expressly warranted by the manufacturer of such parts of Goods. Notwithstanding the foregoing, any warranty with respect to such parts of Goods and any remedies available as a result of a breach thereof shall be subject to all of the procedures, limitations, and exclusions set forth herein.

THE WARRANTIES HEREIN ARE IN LIEU OF ALL WARRANTIES, EXPRESS, IMPLIED, STATUTORY, OR OTHERWISE. IN PARTICULAR, SCC MAKES NO WARRANTY OF MERCHANTABILITY OR FITNESS FOR A PARTICULAR PURPOSE.

No representative, agent or dealer of SCC has authority to modify, expand, or extend this Warranty, to waive any of the limitations or exclusions, or to make any different or additional warranties with respect to Goods.

**Period of Limitations.** No claim, suit or other proceeding may be brought by Purchaser for any breach of the foregoing warranty or this Agreement by SCC or in any way arising out of this Agreement or relating to the Goods after one year from the date of the breach. In the interpretation of this limitation on action for a breach by SCC, it is expressly agreed that there are no warranties of future performance of the goods that would extend that period of limitation herein contained for bringing an action.

**Indemnifications.** Purchaser agrees to indemnify, hold harmless, and defend SCC if so requested, from any and all liabilities, as defined herein, suffered, or incurred by SCC as a result of, or in connection with, any act, omission, or use of the Goods by Purchaser, its employees or customers, or any breach of this Agreement by Purchaser. Liabilities shall include all costs, claims, damages, judgments, and expenses (including reasonable attorney fees and costs).

**Remedies of SCC.** SCC's rights and remedies shall be cumulative and may be exercised from time to time. In a proceeding or action relating to the breach of this Agreement by Purchaser, Purchaser shall reimburse SCC for reasonable costs and attorney's fees incurred by SCC. No waiver by SCC of any breach of Purchaser shall be effective unless in writing nor operate as a waiver of any other breach of the same term thereafter. SCC shall not lose any right because it has not exercised it in the past.

**Applicable Law.** This Agreement is made in Michigan and shall be governed by and interpreted according to Michigan law. Any lawsuit arising out of this Agreement or the Goods may be handled by a federal or state court whose district includes Muskegon County, Michigan, and Purchaser consents that such court shall have personal jurisdiction over Purchaser.

**Miscellaneous.** If any provision of this Agreement is found to be invalid or unenforceable under any law, the provision shall be ineffective to that extent and for the duration of the illegality, but the remaining provisions shall be unaffected. Purchaser shall not assign any of its rights nor delegate any of its obligations under this Agreement without prior written of SCC. This Agreement shall be binding upon and inure to the benefit of SCC and Purchaser and each of their legal representatives, successors and assigns.

SCC warrants its products to be free of defects in materials and workmanship under normal use and service for a period of one (1) year from the date of delivery.

This warranty is extended only to the original purchaser for use of the Goods. It does not cover normal wear parts such as plastic tongs, tong holders, tong cables, bag holders, or acrylic dividers.

**General Conditions.** All service labor and/or parts charges are subject to approval by SCC. Contact the Customer Service Department in writing or call 231-798-8888.

All claims must contain the following information: (1) model & serial code number of equipment; (2) the date and place of installation; (3) the name and address of the agency which performed the installation; (4) the date of the equipment failure; and (5) a complete description of the equipment failure and all circumstances relating to that failure.

Once the claim has been determined to be a true warranty claim by SCC's Customer Service Department, the following procedure will be taken: (1) replacement parts will be sent at no charge from SCC on a freight prepaid basis; (2) reimbursement for service labor will be paid if the following conditions have been met— (a) prior approval of service agency was awarded from the Customer Service Department; and (b) an itemized statement of all labor charges incurred is received by the Customer Service Department. The cost of the service labor reimbursement will be based on straight time rates and reasonable time for the repair of the defect.

If problems occur with any compressor, notify SCC's Customer Service Department immediately. Any attempt to repair or alter the unit without prior consent from the Customer Service Department will render any warranty claim null and void. This warranty and protection plan does not apply to any condensing unit or any part thereof which has been subject to accident, negligence, misuse, or abuse, or which has not been operated in accordance with the manufacturer's recommendations or if the serial number of the unit has been altered, defaced, or removed.

**Limit of Liability.** The limit of liability of SCC toward the exchange cost of the original condensing unit, F.O.B. SCC, Norton Shores, MI, of each motor-compressor assembly replaced during the warranty shall not exceed manufacturer's current established wholesaler's exchange price and in no case shall the labor of removing or replacing the motor-compressor or parts thereof be the responsibility of SCC.