

DP Series - DPHS Service Modular Inline Hot Food Cases



Inline module for heated drop in pans.

Models

DP96.4614A

DP10H.4613

Applications

- One-sided module with drop in pans
- Choice of 8, 10, 12, & 16 half pan sizes
- Service Application
- Heated temperature integrated average 160°F

Standard Features

- Stainless steel steam heated wells with individual controls for each well
- Laminated exterior
- Silver posts & glass sneeze guard
- Solid surface tops
- Non-refrigerated storage
- Stainless steel rear panels
- ETL certified to CAN/CSA 22.2, conforms to UL 471 & NSF 4

Options

- Choice of solid surface finishes
- Black posts
- Other base styles available

Specifications - DPHS Cases

Model	LxDxH
DP96.4614A	144x36-5/8"x54-3/4"
DP10H.4613	144"x36-5/8"x54-3/4"

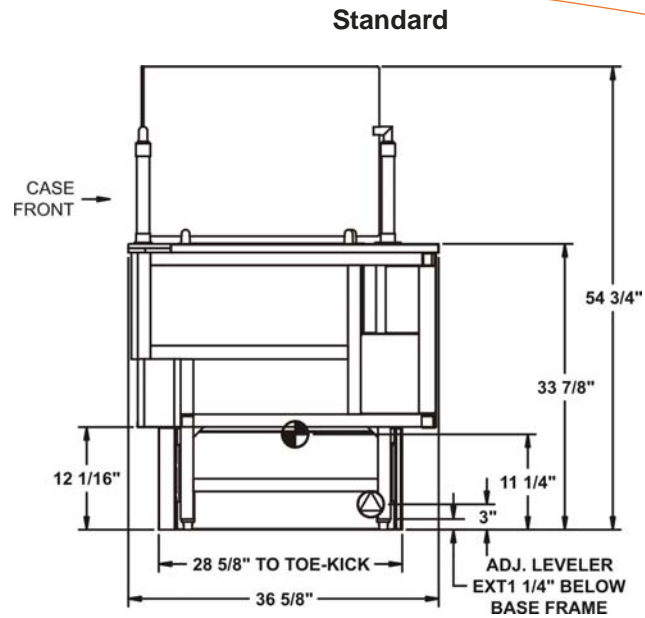

IMPORTANT NOTES

INTENDED ENVIRONMENT

Designed to operate in ambient conditions of 75°F with 55% relative humidity.

Integrated average product temperature of 41°F.

INTENDED USE

Unpackaged refrigerated products.

For more information on any of our products or services please visit us on the web at:
www.structuralconcepts.com

INFORMATION IS SUBJECT TO CHANGE WITHOUT NOTICE.

