

DP Series - DPHSS Self-Service Modular Inline Cases

Models

DP58H
DP610H
DP812H
DP1016H



Applications

- One-sided module with hot wells for self-service pans
- Choice of 8, 10, 12, & 16 half pan sizes
- Angled pans
- Temperature integrated average 160F°
- Heated pan modules designed to be used with refrigerated pan & soup module

Inline module with heated drop in pans.

Standard Features

- Stainless steel well assembly
- Individual controls for each well
- Mirror back panel
- Glass top, sides & sneeze guard
- Non-refrigerated storage drawer in base
- Laminated exterior panels
- Solid surface package ledge
- ETL certified to CAN/CSA 22.2, conforms to UL 471 & NSF 4

Options

- Choice of solid surface finishes

ONE PART PASSION, TWO PARTS SCIENCE



Specifications - DPHSS Cases

Model	LxDxH
DP58H	68"x40-3/8"x58-1/2
DP610H	81"x40-3/8"x58-1/2
DP812H	94"x40-3/8"x58-1/2
DP1016H	120"x40-3/8"x58-1/2

Standard

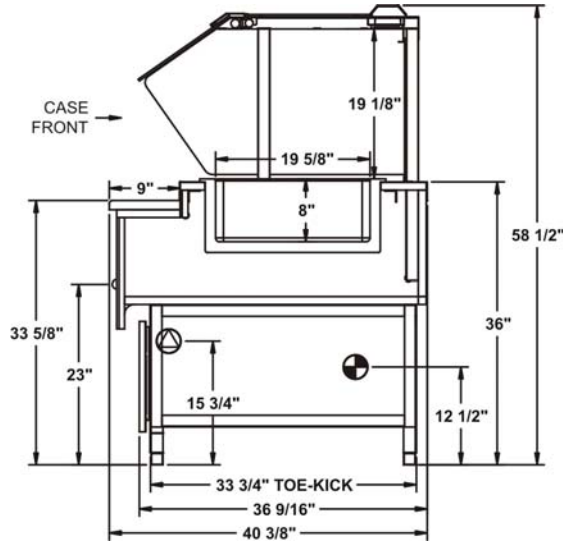

IMPORTANT NOTES

INTENDED ENVIRONMENT

Designed to operate in ambient conditions of 75°F with 55% relative humidity.

Integrated average product temperature of 41°F.

INTENDED USE

Unpackaged refrigerated products.

INFORMATION IS SUBJECT TO CHANGE WITHOUT NOTICE.

