

DP Series - DPRI Modular Island Cases



Models

DP58R
DP610R
DP812R
DP1016R

Applications

- One-sided modules with cold wells for self-service pans combine to create island displays
- Forced air over & under pans
- Choice of 8, 10, 12, & 16 half pan sizes
- Angled pans
- Medium temperature integrated average 41°F
- Refrigerated pan modules designed to be used with heated pan & soup module to create an island display

Modular refrigerated drop in pan cases that create island displays

Standard Features

- Stainless steel well assembly
- Pans displayed at an angle with cold air blowing above & below each pan
- Mirror back panel
- Glass top, sides & sneeze guard
- Refrigerated storage drawer in base
- Laminated exterior panels
- Solid surface package ledge
- Remote refrigeration with TXV
- ETL certified to CAN/CSA 22.2, conforms to UL 471 & NSF 7

Options

- Choice of solid surface finishes

ONE PART PASSION, TWO PARTS SCIENCE



Specifications - DPRI Cases

Model	L*xDxH
DP58R	68"x40-3/8"x58-1/2
DP610R	81"x40-3/8"x58-1/2
DP812R	94"x40-3/8"x58-1/2
DP1016R	120"x40-3/8"x58-1/2

*without 1" end panels

STANDARD

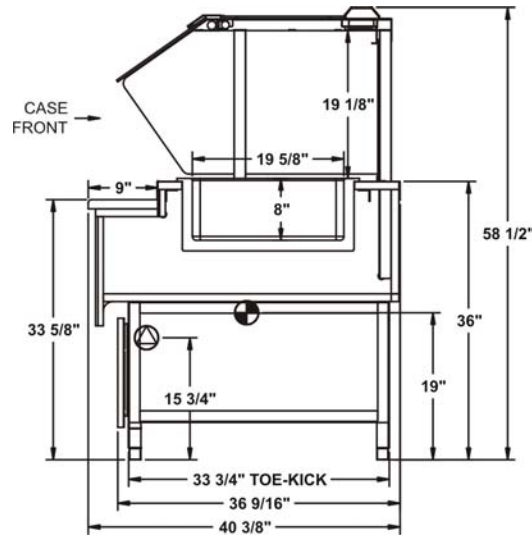

IMPORTANT NOTES

INTENDED ENVIRONMENT

Designed to operate in ambient conditions of 75°F with 55% relative humidity.

Integrated average product temperature of 41°F.

INTENDED USE

Unpackaged refrigerated products.

INFORMATION IS SUBJECT TO CHANGE WITHOUT NOTICE.

