

ENCORE[®] SERIES

INSTALLATION AND OPERATING MANUAL

PN 54075

SERVICE-AMBIENT TABLE SPHERICAL
GLASS OUTSIDE WEDGE MERCHANDISERS

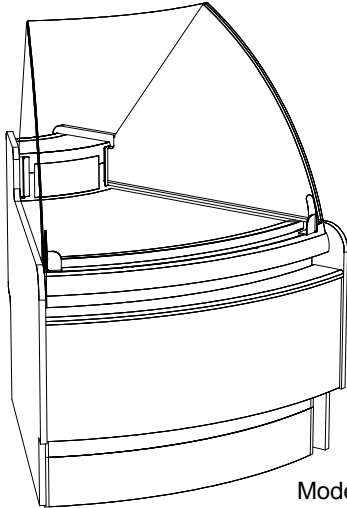

Model DTSOW45

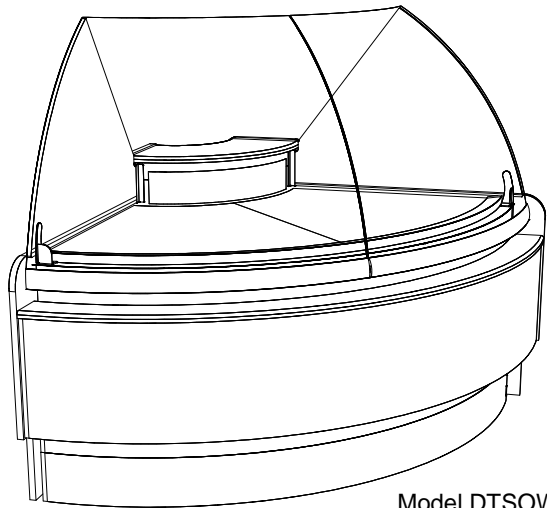

Model DTSOW90

SERVICE-AMBIENT TABLE SPHERICAL
GLASS INSIDE WEDGE MERCHANDISERS

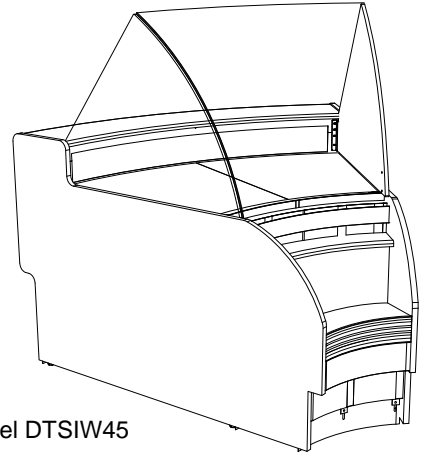

Model DTSIW45

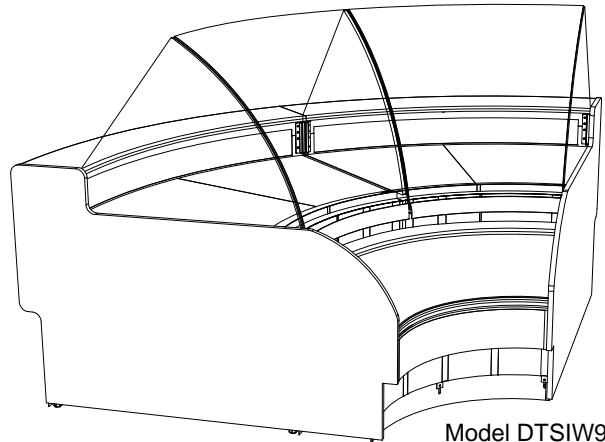

Model DTSIW90

SERVICE-AMBIENT TABLE
SPHERICAL GLASS MERCHANDISERS

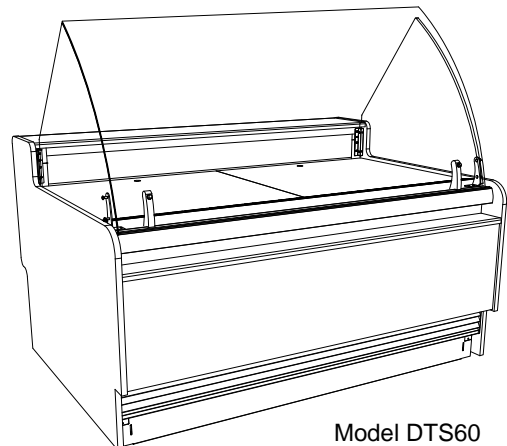

Model DTS60

Model DTS36	38 3/4"L* x 44 1/2"D x 54"H~
Model DTS48	50 3/4"L* x 44 1/2"D x 54"H~
Model DTS60	62 1/2"L* x 44 1/2"D x 54"H~
Model DTSOW45	41-1/4"L* x 45 3/8"D x 54"H~
Model DTSOW90	88 3/4"L* x 47 1/4"D x 54"H~
Model DTSIW45	14 1/2"L* x 54 1/2"D x 54 1/8"H~
Model DTSIW90	24 1/4"L* x 54 1/2"D x 54 1/8"H~

*Includes End Panels
~ With Adjustable Levelers Extended
1 1/2" Below Base Frame



888 E. Porter Road · Muskegon, MI 49441 Phone: 231.798.8888 Fax: 231.798.4960 www.structuralconcepts.com

TABLE OF CONTENTS

OVERVIEW AND WARNINGS	3
INSTALLATION	4
ADJOINING CASES	5
SHELF OPTION	6
TROUBLESHOOTING	7
CLEANING SCHEDULE	8
TECHNICAL SERVICE CONTACT INFORMATION & WARRANTY INFORMATION	9

OVERVIEW

- This Structural Concepts® Encore® Service Non-Refrigerated case is designed to merchandise packaged / unpackaged bakery products at ambient temperatures.
- This case should be installed and operated according to this Installation-Operating Manual to insure proper performance.
- This unit is designed for the display of products in ambient store conditions where temperatures and humidity are maintained at a maximum of 75°F / 24°C and 55% relative humidity.

This merchandiser is designed for the display of non-hazardous, packaged / unpackaged bakery products (per NSF Std. 2 – 1999).

INSTALLATION

1. Remove Unit From Skid

- Remove case from skid and place into proper position.
- To prevent damage, support case while sliding skid out from under case.
- See illustration.

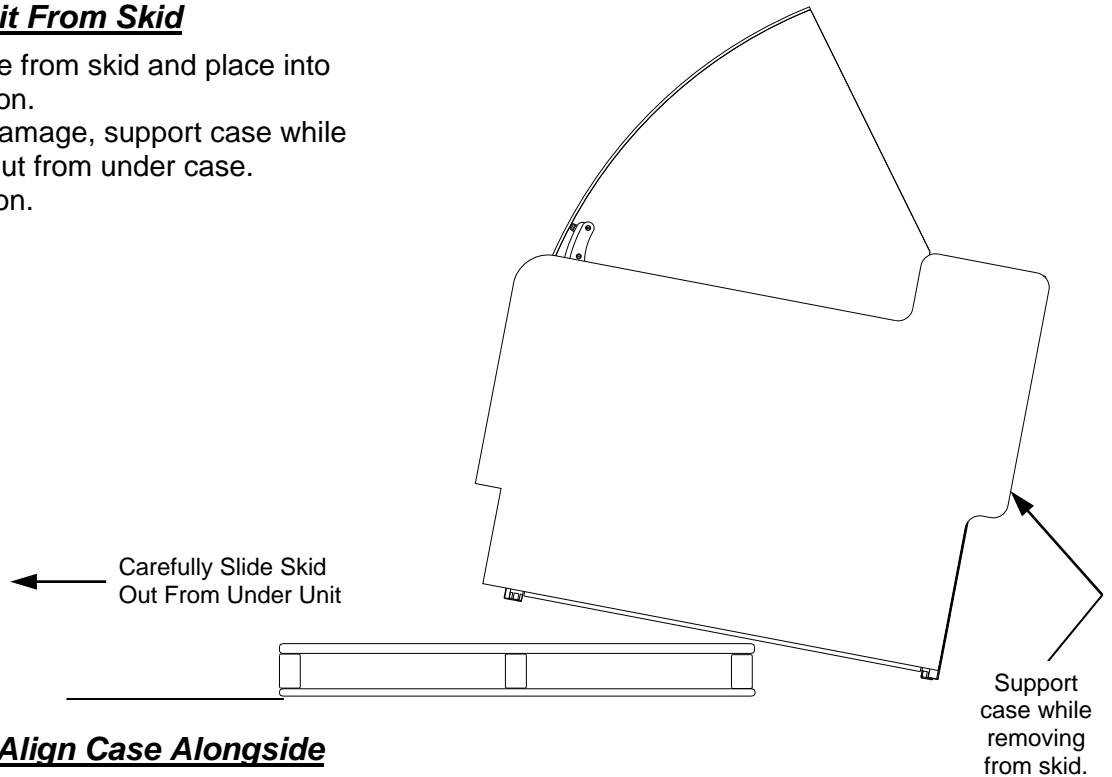

2. Position & Align Case Alongside Other Cases

- Before adjusting levelers, make certain that the case is in proper position and aligned with adjoining case(s).
- This may require the repositioning of the case you are installing or the already positioned case(s).

3. Adjust Levelers

- After case is in proper position, adjust case so it is level and plumb (see illustration at right).
- You may need to remove front and/or rear Toe-Kick to access levelers.
- Use adjustable wrench to adjust leveler.
- Depending upon case weight it may be necessary to use a Pry Bar to accomplish this task.
- Do not use Pry Bar on Toe-Kick as it may buckle.
- Do not use Pry Bar on End Panel as it may chip.
- Use Pry Bar **ONLY** on Base Frame to avoid damaging case.
- See illustration and photos at right.

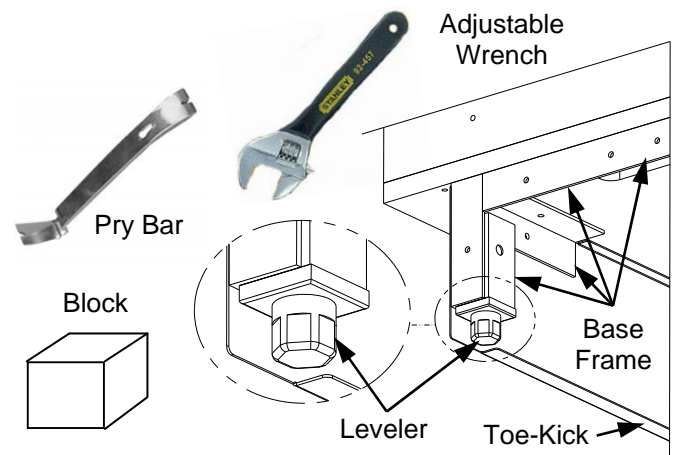

CASE ADJOINMENT

Case Adjoinment

- Case is shipped with end panel removed where it is to be adjoined.
- For proper case adjoinment, use the SCC®-provided 1/4-20 x 2 1/2" nuts, bolts and washers.
- Adjoinment is to be at locations ballooned below.
- SCC® Model shown below is for illustrative purposes. Your model's appearance may slightly vary.

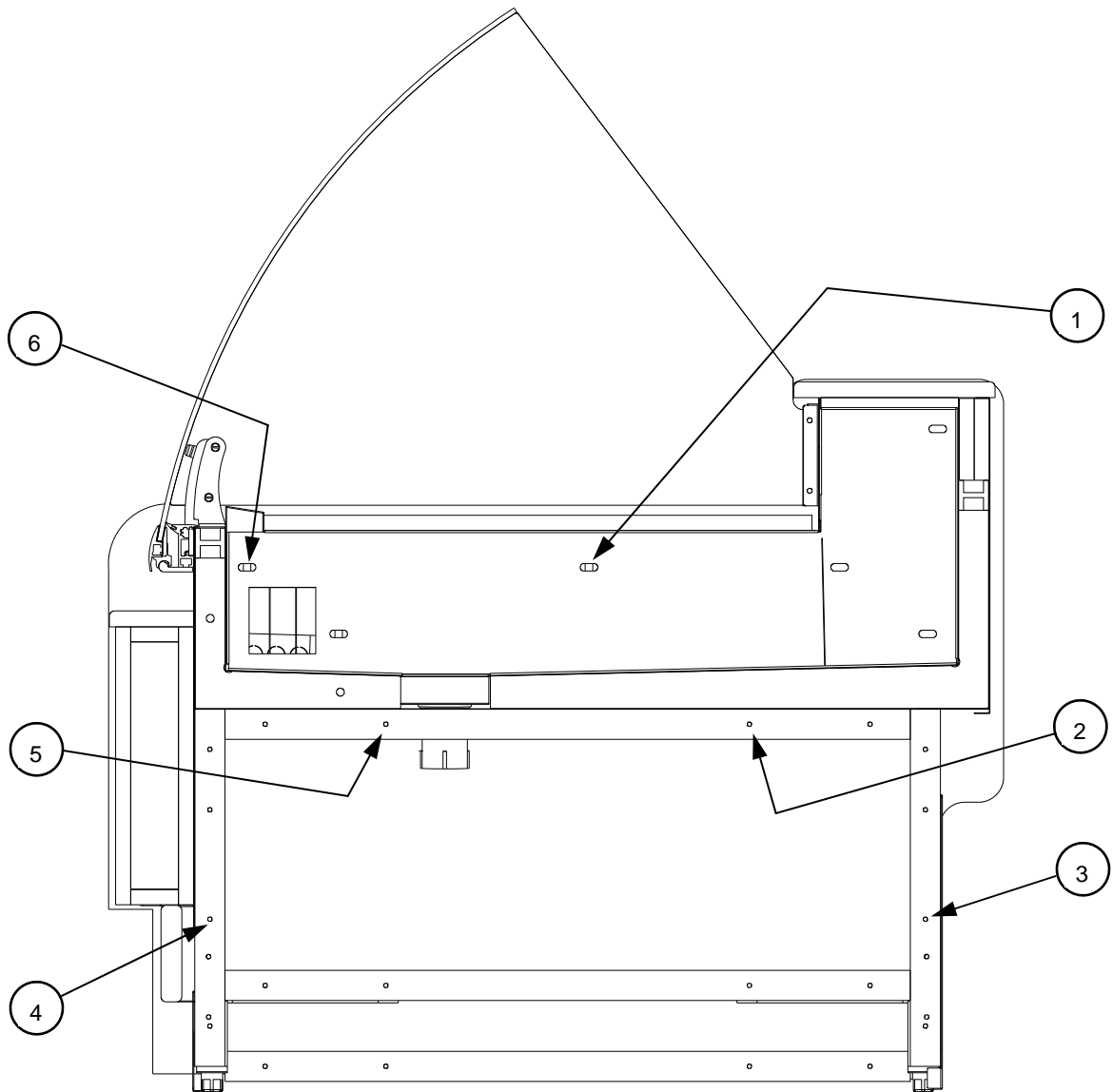

SHELF OPTION

LED light removal / replacement:

- Contact Structural Concepts' Technical Service Department at 1.800.433.9489 for replacement parts.
- Plug is to connect to LED light at raceway side of case.
- To remove LED light fixture, disconnect existing LED light from its brackets & self-adhesive tape.
- Then, firmly grasp LED light while applying outward pressure to brackets.
- Twist LED away from bracket to release.
- See illustrations at top and mid-right.

Plug and cord positioning:

- Plug is to connect to LED light at raceway side of case.
- Before attaching LED light to case, plug must connect to LED properly without cord doubling-back.
- See photos of proper vs. improper connections at below right.

Proper plug insertion into LED light socket:

- Plug must be inserted into LED light properly or the LED will not light up.
- ⇒ **Important! The plug's oval form MUST be inserted into LED's oval form. The plug's flat form must be inserted into the LED's flat form.**
- See illustration at mid-right.

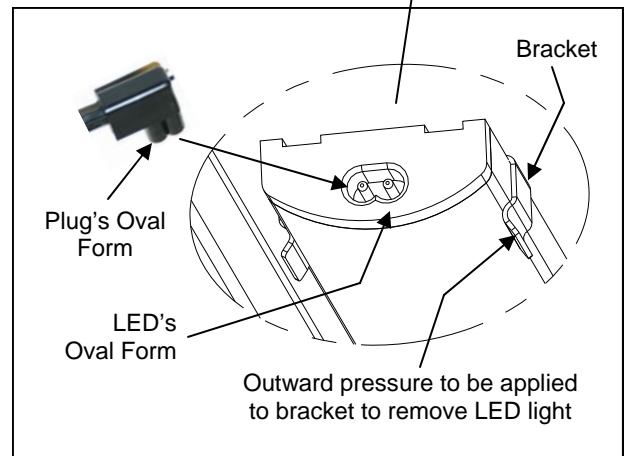
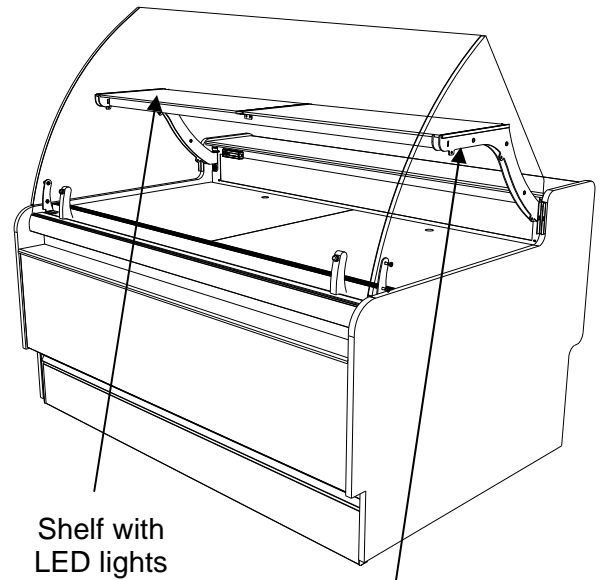
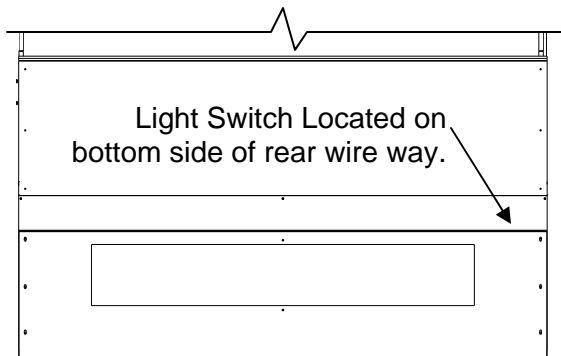

TROUBLESHOOTING

Case Not Properly Lining Up	See Installation Section for instructions on properly aligning case (alongside other cases) and adjusting levelers.

CLEANING SCHEDULE - TO BE PERFORMED BY STORE PERSONNEL

AREA TO BE CLEANED	FREQUENCY	INSTRUCTIONS
Case Exterior	Daily	<u>Glass</u> : Clean outside front and side glass with a household or commercial glass cleaner and a soft cloth or paper towel.
	Daily	<u>End Panels, Front Panel, Toe-Kick, etc.</u> : Wipe off all surfaces with warm water and mild soap solution and non-abrasive cloth.
	Quarterly	<u>Under Case</u> : Remove front toe-kick (4 screws must be removed). Vacuum under case to remove dust and dirt that may collect under the case.
Case Interior	Daily	<u>Glass</u> : Clean inside front and side glass with a household or commercial glass cleaner and a soft cloth or paper towel.
	Weekly	<u>Decks</u> : Wipe off decks with moist cloth.

STRUCTURAL CONCEPTS CORPORATION TECHNICAL SERVICE
PHONE NUMBER: 1.800.433.9489 or For Your Master Service Agent See
WWW.STRUCTURALCONCEPTS.COM/Contact/Master_Service_Agents.asp

WARRANTY INFORMATION

(Note: Standard Limited Warranty can be found at www.Structuralconcepts.com)

All sales by Structural Concepts Corporation (SCC) are subject to the following limited warranty. "Goods" refers to the product or products being sold by SCC.

Warranty Scope: Warranty is for equipment sold in the United States, Canada, Mexico and Puerto Rico. Limited warranty may apply to equipment sold elsewhere.

Warranty; Remedies; Limitations. SCC warrants that if any Goods are found by an authorized representative of SCC not to be of good material or workmanship within one year of the date of shipments SCC will, at its option after inspection by an authorized representative, replace any defective Good or pay the reasonable cost of replacement for any such defective Goods, provided that written notice of the defect is given to SCC within 30 days of the appearance of such defect. If notice is not given within such period, any claim for breach of warranty shall be conclusively deemed to have been waived and SCC shall not be liable under this warranty. If SCC is unable to repair or replace the defective Goods, SCC shall issue a credit to the Purchaser for all or part of the purchase price, as SCC shall determine. The replacement or payment in the manner described above shall be the sole and exclusive remedy of Purchaser for a breach of this warranty. If any Goods are defective or fail to conform to this warranty, SCC will furnish instructions for their disposition. No Goods shall be returned to SCC without its prior consent.

SCC's liability for any defect in the Goods shall not exceed the purchase price of the Goods. SCC SHALL HAVE NO LIABILITY TO PURCHASE FOR CONSEQUENTIAL DAMAGES OF ANY KIND WHATSOEVER, INCLUDING, BUT NOT LIMITED TO, PERSONAL INJURY, PROPERTY DAMAGE, LOST PROFITS, OR OTHER ECONOMIC INJURY DUE TO ANY DEFECT IN THE GOODS OR ANY BREACH OF SCC. SCC SHALL NOT BE LIABLE TO THE PURCHASER IN TORT FOR ANY NEGLIGENT DESIGN OR MANUFACTURE OF THE GOODS, OR FOR THE OMISSION OF ANY WARNING THEREFROM.

SCC shall have no obligation or liability under this warranty for claims arising from any other party's (including Purchaser's) negligence or misuse of the Goods or environmental conditions. This warranty does not apply to any claim or damage arising for or cause by improper storage, handling, installation, maintenance, or from fire, flood, accidents, structural defects, building settlement or movement, acts of God, or other causes beyond SCC's control.

Except as expressly stated herein, SCC makes no warranty, express, implied, statutory or otherwise as to any parts or goods not manufactured by SCC. SCC shall warrant such parts or Goods only (I) against such defects, (II) for such periods of time, and (III) with such remedies, as are expressly warranted by the manufacturer of such parts of Goods. Notwithstanding the foregoing, any warranty with respect to such parts of Goods and any remedies available as a result of a breach thereof shall be subject to all of the procedures, limitations, and exclusions set forth herein.

THE WARRANTIES HEREIN ARE IN LIEU OF ALL WARRANTIES, EXPRESS, IMPLIED, STATUTORY, OR OTHERWISE. IN PARTICULAR, SCC MAKES NO WARRANTY OF MERCHANTABILITY OR FITNESS FOR A PARTICULAR PURPOSE.

No representative, agent or dealer of SCC has authority to modify, expand, or extend this Warranty, to waive any of the limitations or exclusions, or to make any different or additional warranties with respect to Goods.

Period of Limitations. No claim, suit or other proceeding may be brought by Purchaser for any breach of the foregoing warranty or this Agreement by SCC or in any way arising out of this Agreement or relating to the Goods after one year from the date of the breach. In the interpretation of this limitation on action for a breach by SCC, it is expressly agreed that there are no warranties of future performance of the goods that would extend that period of limitation herein contained for bringing an action.

Indemnifications. Purchaser agrees to indemnify, hold harmless, and defend SCC if so requested, from any and all liabilities, as defined herein, suffered, or incurred by SCC as a result of, or in connection with, any act, omission, or use of the Goods by Purchaser, its employees or customers, or any breach of this Agreement by Purchaser. Liabilities shall include all costs, claims, damages, judgments, and expenses (including reasonable attorney fees and costs).

Remedies of SCC. SCC's rights and remedies shall be cumulative and may be exercised from time to time. In a proceeding or action relating to the breach of this Agreement by Purchaser, Purchaser shall reimburse SCC for reasonable costs and attorney's fees incurred by SCC. No waiver by SCC of any breach of Purchaser shall be effective unless in writing nor operate as a waiver of any other breach of the same term thereafter. SCC shall not lose any right because it has not exercised it in the past.

Applicable Law. This Agreement is made in Michigan and shall be governed by and interpreted according to Michigan law. Any lawsuit arising out of this Agreement or the Goods may be handled by a federal or state court whose district includes Muskegon County, Michigan, and Purchaser consents that such court shall have personal jurisdiction over Purchaser.

Miscellaneous. If any provision of this Agreement is found to be invalid or unenforceable under any law, the provision shall be ineffective to that extent and for the duration of the illegality, but the remaining provisions shall be unaffected. Purchaser shall not assign any of its rights nor delegate any of its obligations under this Agreement without prior written of SCC. This Agreement shall be binding upon and inure to the benefit of SCC and Purchaser and each of their legal representatives, successors and assigns.

SCC warrants its products to be free of defects in materials and workmanship under normal use and service for a period of one (1) year from the date of delivery.

This warranty is extended only to the original purchaser for use of the Goods. It does not cover normal wear parts such as plastic tongs, tong holders, tong cables, bag holders, or acrylic dividers.

General Conditions. All service labor and/or parts charges are subject to approval by SCC. Contact the Customer Service Department in writing or call 231-798-8888.

All claims must contain the following information: (1) model & serial code number of equipment; (2) the date and place of installation; (3) the name and address of the agency which performed the installation; (4) the date of the equipment failure; and (5) a complete description of the equipment failure and all circumstances relating to that failure.

Once the claim has been determined to be a true warranty claim by SCC's Customer Service Department, the following procedure will be taken: (1) replacement parts will be sent at no charge from SCC on a freight prepaid basis; (2) reimbursement for service labor will be paid if the following conditions have been met— (a) prior approval of service agency was awarded from the Customer Service Department; and (b) an itemized statement of all labor charges incurred is received by the Customer Service Department. The cost of the service labor reimbursement will be based on straight time rates and reasonable time for the repair of the defect.

If problems occur with any compressor, notify SCC's Customer Service Department immediately. Any attempt to repair or alter the unit without prior consent from the Customer Service Department will render any warranty claim null and void. This warranty and protection plan does not apply to any condensing unit or any part thereof which has been subject to accident, negligence, misuse, or abuse, or which has not been operated in accordance with the manufacturer's recommendations or if the serial number of the unit has been altered, defaced, or removed.

Limit of Liability. The limit of liability of SCC toward the exchange cost of the original condensing unit, F.O.B. SCC, Norton Shores, MI, of each motor-compressor assembly replaced during the warranty shall not exceed manufacturer's current established wholesaler's exchange price and in no case shall the labor of removing or replacing the motor-compressor or parts thereof be the responsibility of SCC.