

ENCORE[®]
SERIES

INSTALLATION & OPERATING MANUAL

PN 54480

SERVICE REFRIGERATED DISPLAY CASE (SELF-CONTAINED & REMOTE)

PLEASE NOTE THE FOLLOWING:

1. YOUR SPECIFIC MODEL NUMBER IS ON THE SERIAL LABEL ON CASE REAR (NEAR MAIN POWER SWITCH).
2. ILLUSTRATIONS SHOWN BELOW LIST “[L]” TO REFLECT VARYING CASE LENGTH DIMENSIONS.
3. CASES SHOWN REFLECT FULL & OPEN END PANELS / STRAIGHT OR ANGLED BASES. YOURS MAY DIFFER.
4. SEE “MODELS (AND THEIR RESPECTIVE CASE DIMENSIONS) LISTED IN THIS MANUAL” SECTION FOR ADDITIONAL INFORMATION REGARDING SPECIFIC CASE DIMENSIONS OF STANDARD MODELS AND CDRs.

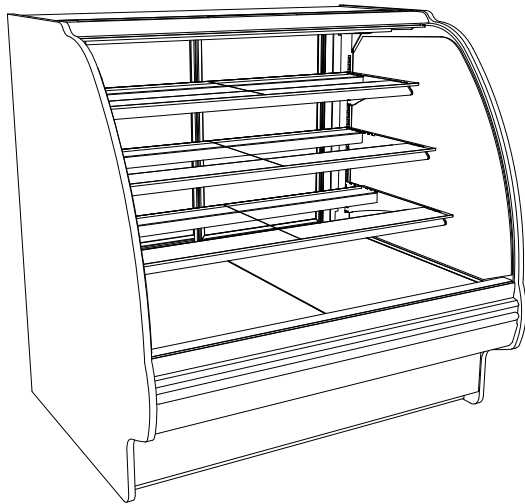

HV[L]R - Angled Base &
Full Ends

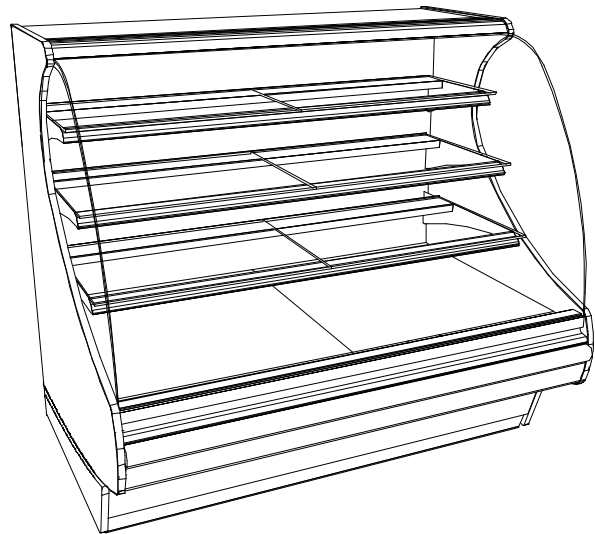

HV[L]R - Angled Base
Cutaway Ends

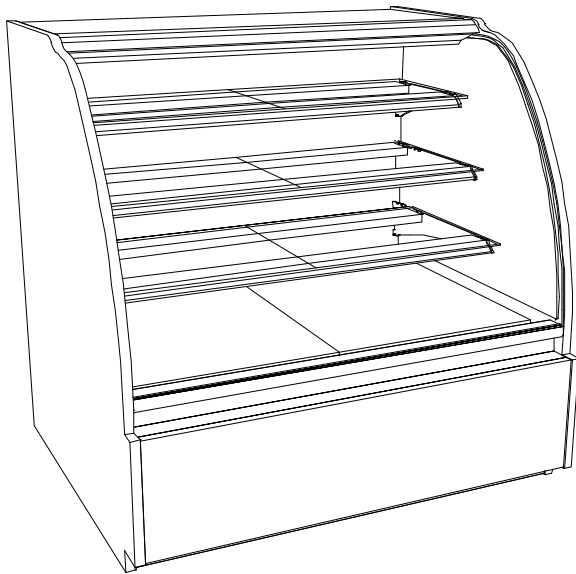

HVC48R - Straight Base &
Full Ends (Standard Case)

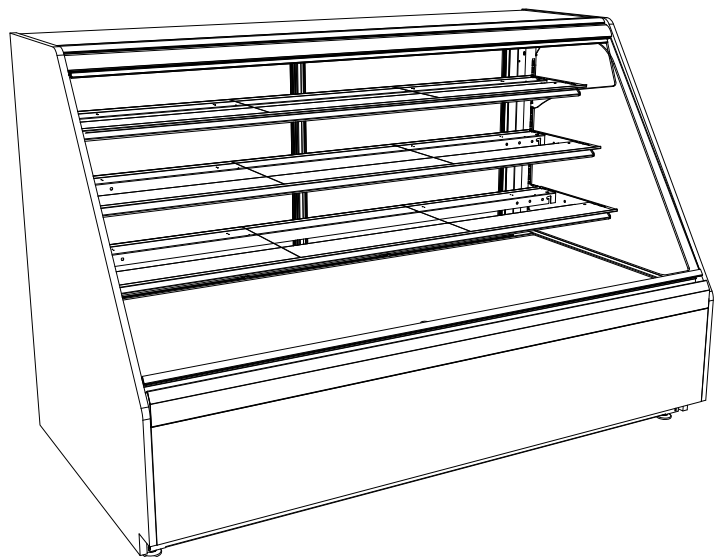

HVK[L]R
Straight Base - Full Ends



TABLE OF CONTENTS

TABLE OF CONTENTS	2
MODELS LISTED IN MANUAL (AND DETERMINING THEIR RESPECTIVE CASE DIMENSIONS)	3
OVERVIEW AND WARNINGS	4
INSTALLATION: REMOVAL FROM SKID, REMOVING LOWER FRONT PANELS	5
INSTALLATION: ADJUSTING FRONT PANELS / ADJOINING UNITS / GLASS SHELVING	6
INSTALLATION: ELEC. CONNECTIONS / LOCKING CASTERS / ADJUSTING LEVELERS	7
INSTALLATION: FRONT GLASS ALIGNMENT & ADJUSTMENT (CURVED & FLAT)	8
INSTALLATION: REFRIG. LINES / STUB-UPS / DRAINS / WIRING DIAGRAMS / VENTILATION ..	9
INSTALLATION: DISPLAY CASE START-UP	10
OPTIONAL NIGHT AIR CURTAIN INSTALLATION & OPERATING INSTRUCTIONS	11
DRAIN, HOSE AND BRACKET PLACEMENT ILLUSTRATIONS	12
MAINTENANCE FUNDAMENTALS - STANDARD LIGHT FIXTURES	13
MAINTENANCE FUNDAMENTALS - LED LIGHTS/BRACKETS/SHELVES/DRAIN/TXV VALVE	14
MAINTENANCE FUNDAMENTALS - REFRIG. PKG., TEMP. CONTROLLER, EVAP. PAN	15
MAINTENANCE FUNDAMENTALS - REAR SLIDING DOORS	16
CLEANING SCHEDULE	17
TROUBLESHOOTING - GENERAL ISSUES	18-20
TROUBLESHOOTING - CONDENSING SYSTEM	21
TROUBLESHOOTING - EVAPORATOR SYSTEM	22
PREVENTIVE MAINTENANCE (TO BE PERFORMED BY TRAINED SERVICE PROVIDER)	23
SERIAL LABEL INFORMATION & LOCATION	24
TEMPERATURE CONTROLLER - CAREL®	25-27
TECHNICAL SERVICE CONTACT INFORMATION & WARRANTY INFORMATION	28

MODELS LISTED IN THIS MANUAL (AND DETERMINING THEIR RESPECTIVE CASE DIMENSIONS)

DETERMINING YOUR MODEL AND ITS CASE DIMENSIONS:

Note 1. Your model number can be found on serial label at rear of case (near main power switch).

Note 2. Dimensions of most models can be found at www.structuralconcepts.com. Simply enter the case model number into the Product Number Search box. Click the **product specification** link for complete dimensions.

Note 3. If your specific model is not found, contact technical service (phone number is listed at Technical Service section in this manual) for dimensions.

Note 4. CDRs (Customer Design Requests) are listed with a 4-digit number. All CDR dimensions are identical to standard model dimensions.

THIS OPERATING MANUAL ENCOMPASSES THE FOLLOWING MODELS (AND THEIR RESPECTIVE CDRs):

Model HVC38R
Model HVC48R
Model HVC48R.4718

Model HVK48R
Model HVK56R
Model HVK74R
Model HVK112R

Model HVK74R.4692

Model HV38R
Model HV48R
Model HV56R
Model HV74R
Model HV96R
Model HV112R

Model HV48R.3462

Model HV48R.3659
Model HV48R.4107
Model HV56R.2965A
Model HV56R.3986
Model HV56R.4108
Model HV74R.3225A
Model HV74R.4109
Model HV74R.5140
Model HV96R.4110
Model HV112R.3002A
Model HV112R.4111

OVERVIEW AND WARNINGS

OVERVIEW

- These Structural Concepts Encore® service cases are designed to merchandise packaged products at 41°F or less product temperatures.
- These cases should be installed and operated according to this operating manual's instructions to insure proper performance. Improper use will void warranty.

This unit is designed for the display of products in ambient store conditions where temperatures and humidity are maintained within a specific range.

- For NSF® Type 1 Conditions (most cases): ambient conditions are to be at 55% max. humidity / 75°F.
- For NSF® Type 2 Conditions: ambient conditions are to be at 60% maximum humidity / 80°F.
- If unsure if your case is Type 1 or Type 2, contact Structural Concepts Technical Service (see Technical Service section in this manual for phone number).

Caution: Do not allow air conditioning, electric fans, open doors or windows to create air currents around display case as this may detrimentally affect proper case temperatures and operation.



ATTENTION INSTALLER
This equipment must be installed in compliance with all applicable NEC, federal, state and local plumbing codes.



WARNING
Risk of electric shock.
Disconnect power before servicing unit



WARNING
More than one source of electrical supply is employed with units that have separate circuits.
Disconnect all sources before servicing.



WARNING
Hazardous moving parts. Do not operate unit with covers removed.
Fan blades may be exposed when deck panel is removed.
Disconnect power before removing deck panel.



WARNING
Evaporator Pan is Hot! Disconnect and allow to cool before cleaning or removing from case.



CAUTION
Lamps have been treated to resist breakage and must be replaced with similarly treated lamps.

INSTALLATION: REMOVAL FROM SKID, REMOVING LOWER FRONT PANELS

1. Remove Case From Skid (Levelers)

- Remove shipping brace that may be securing case to skid.
- Support case to prevent tipping.
- **Caution! Levelers can be damaged if case hits floor with heavy force!**
- Carefully slide unit to rear of skid and tip backward off skid.
- Illustration may not reflect every feature or option of your particular case.

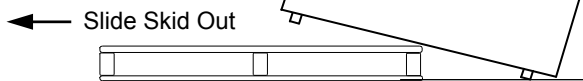

Case can be repositioned with pallet truck when front lower panel is removed. Blocking may be necessary to obtain adequate height.

2. Remove Case From Skid (Casters)

Remove shipping brackets that may be securing casters to skid

- Place ramp up against skid (to allow case to smoothly slide off from skid).
- Maintain support of case at all times or center of gravity may cause case to fall.
- Unlock Casters. Roll unit to rear of skid.

Roll down ramp and off from skid.

Note: Illustrations shown reflect a general outline of sample cases and do not reflect features or options of your particular model.

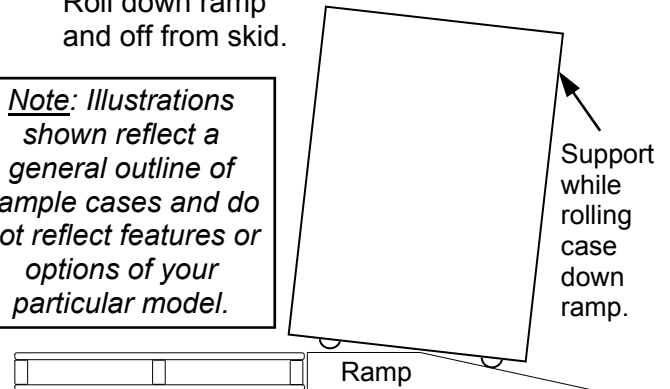

3A. Removing Angled Lower Front Panels

Upper panel support.

- Remove screws located behind upper front panel.

Lower panel support.

- *Most applications*, screws secure the lower panel support (located below front panel) to the unit.

See illustration at right.

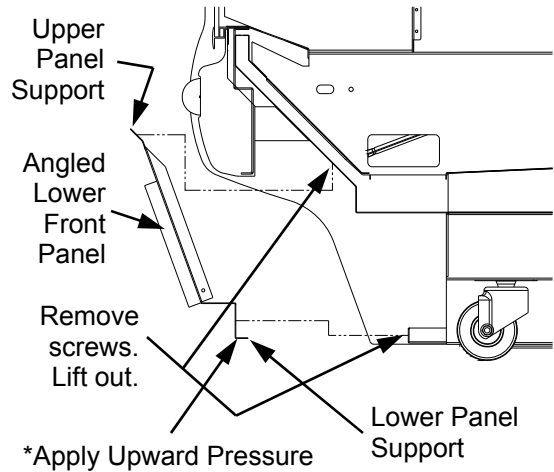

3B. Removing Vertical Lower Front Panels

Front Panel Upper Support

- Lift Front Glass.
- Remove the caps and screws holding Deck Support in place.

Front Panel Lower Support

- For most display cases, screws secure Front Panel Lower Support to Base.
- Remove screws holding Front Panel Lower Support to Display Case Base.

Vertical Lower Front Panel can now be removed (see illustration at lower right).

**Alternate applications (for cases without lower panel screws):* Apply upward pressure to lower panel support to disengage lower support panel tabs from slots located in the base at both ends of the unit.

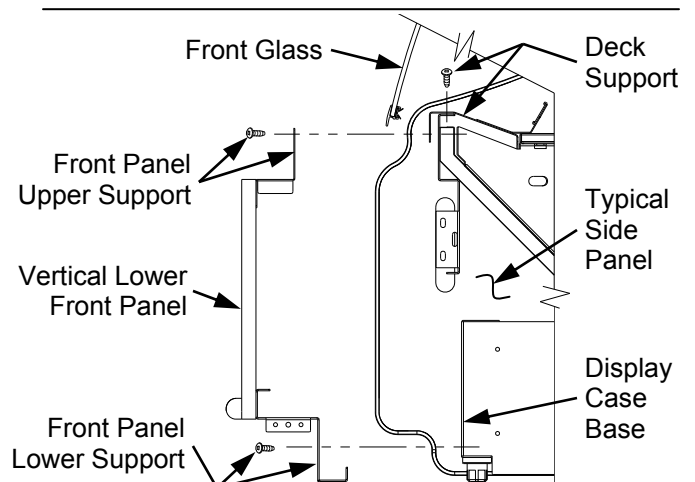

4. Adjusting Upper Front Panels

- Remove screw cover and loosen adjustment screws.
- Adjust alignment and tighten screws.
- See illustration at mid-right.

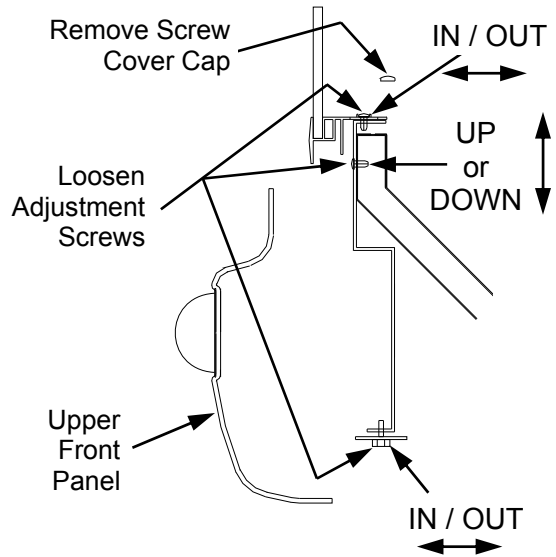

5. Bolting and Caulking Units Together

Follow these steps to assure a secure, level lineup.

- Begin all lineups leveling from highest point of floor.
- After the 'first' case is level, apply industrial grade butyl caulk on non-visible areas (at case end). Use industrial grade silicone sealant on visible areas (at case end).
- Form Two (2) Caulk/Sealant Lines:** (Sanitation and Refrigeration). See illustration at mid-right for outline of caulk/sealant lines.
- Line up 'second' case bolt-hole to bolt-hole to 'first' case.
- Using SCC-supplied bolts (found in installation packet), insert bolts in bolt hole locations (shown at right). You may need to remove decking to access lower bolt holes.
- Caution! Front of cases MUST be flush with each other! After leveling, all cases to be same height.
- Using SCC-supplied nuts & bolts, **lightly tighten** each of the 5 to 8 bolts in a cross-wise pattern. Work your way around the pattern, tightening more firmly at each pass. **Do not** firmly tighten one bolt and then start on the next!
- After the cases are bolted together, level the 'second' case. Repeat this process for each case to be adjoined.
- After all lined-up cases are level, seal all seams with industrial grade silicone sealant.

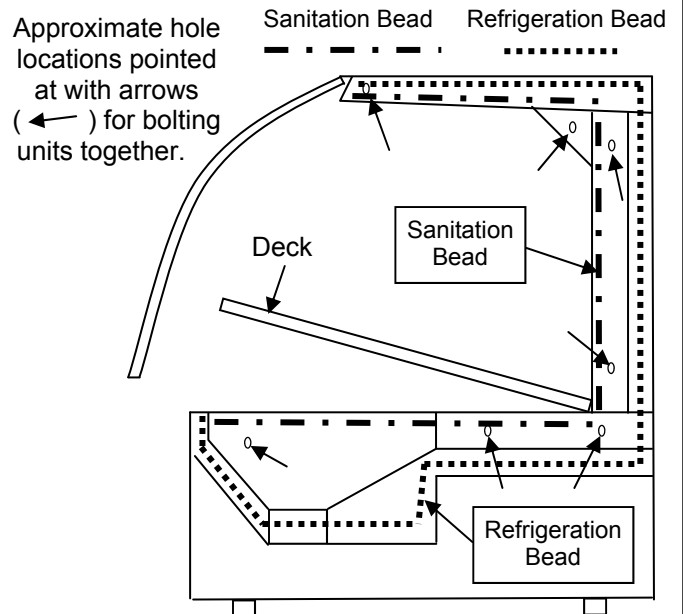

6. Glass Shelving

Glass shelving will be packed separately.

- Caution! Carefully remove from packaging.
- Grasp firmly and carefully install.
- *Caution! Check that plastic edging is intact before placing glass shelving onto brackets!*
- Plastic edging must NOT be removed from glass shelves. Contact Structural Concepts for replacement edging (see **TECHNICAL SERVICE CONTACT INFORMATION** section).
- Check that glass shelving is in proper position before placing product in case.
- See illustration at lower-right.

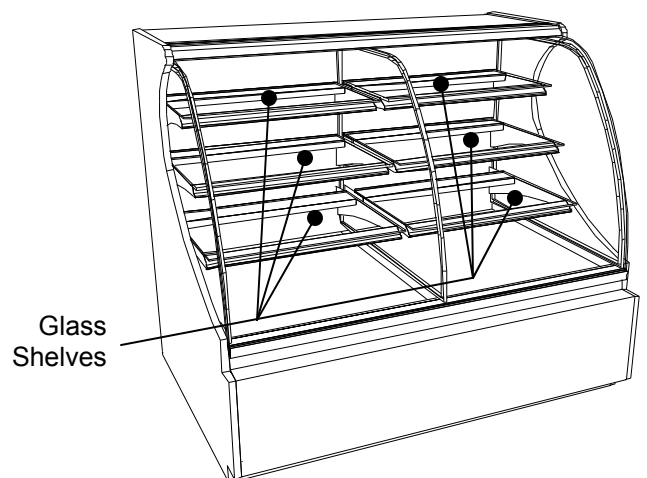

7. Electrical Connections

A. Rear Wire-Ways

- Remove screws from rear wire-way cover to access electrical leads.
- Wiring runs case to case through base cut-outs.
- Knockout is provided in bottom of wire-way for stub-up connection.
- See illustration at top-right.

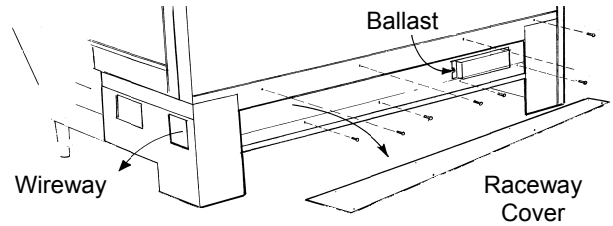

Note: Wiring process must be performed by certified electricians only.

- Voltage rating is on serial label at case rear.

B. Rear Ballast Box

- Remove 4 screws from ballast box face.
- Remove screws from rear panel (if any).
- Remove 3 screws from inner support.
- Knockouts are located on side and rear of box for making electrical connections.

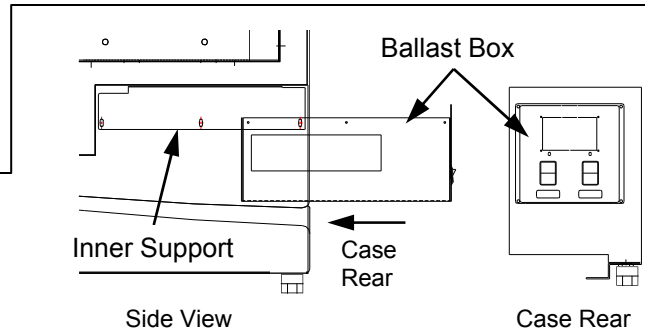

Note: Wiring process must be performed by certified electricians only.

- Serial label (at case rear) lists voltage rating.

C. Front Ballast Box

- Remove front panel.
- Stub-up connections are in ballast box.
- Remove ballast box covers.
- Knockouts are on sides and front of ballast assembly for making electrical connections.

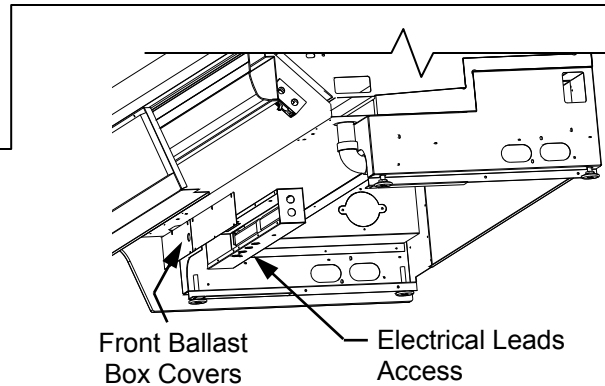

Note: Wiring process must be performed by certified electrician only.

- Voltage rating is on serial label at case rear.

8. Cases With Casters: Lock and Unlock

- To lock casters, press down on lever.
- To unlock casters, pull lever up.
- See illustration at right.

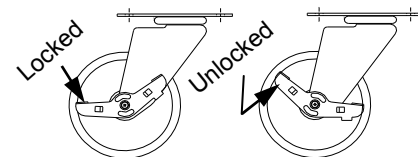

9. Cases With Levelers: Adjust Levelers

- After case is in position, adjust case so it is level and plumb (see illustration at right).
- You may need to remove front and/or rear Toe-Kick to access levelers.
- Use adjustable wrench (and possibly a pry bar) to adjust leveler.
- Do not use pry bar on toe-kick (it may buckle).
- Do not use pry bar on end panel (it may chip).
- Use pry bar ONLY on base frame to avoid damaging case.
- Use a block to reach base frames with pry bar.
- See illustrations at right.

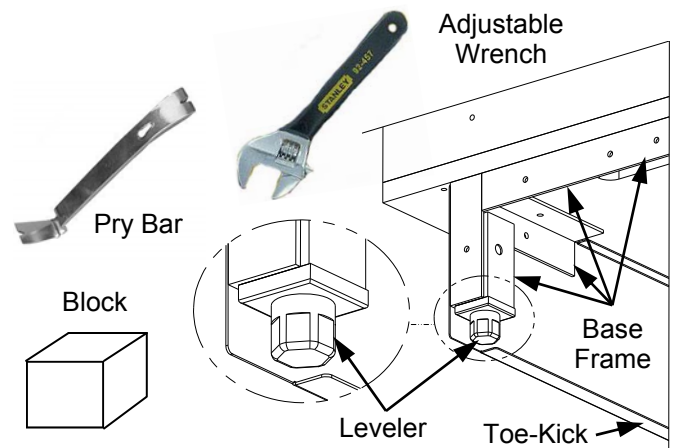

10. Front Glass Alignment & Adjustment via Levelers (For Curved and Flat Front Glass)

- Proper alignment of the front glass is important to create and maintain a seal inside the case.
- Improper alignment can cause air leaks compromising the environment inside the case and create condensation.
- Follow the five steps listed below to assure proper front glass alignment.

1. Side-to-Side Leveling: Place a level on top of display case (parallel to the front glass). Raise or lower either side of the case by rotating levelers to center the level bubble.

2. Front-to-Back Leveling: Place a level on top of case, perpendicular to front glass. Raise or lower either side of case by rotating levelers to center the level bubble. Double-check the side-to-side level.

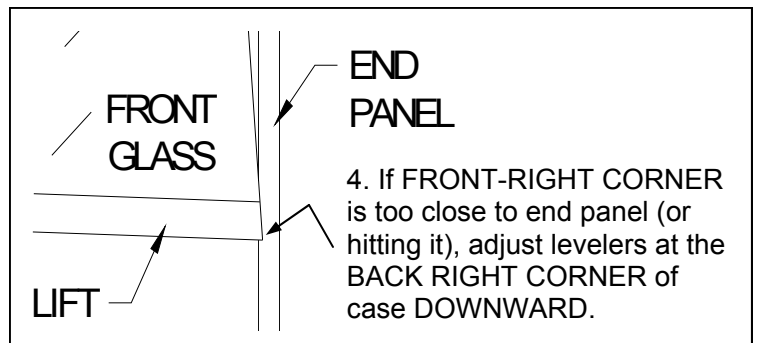
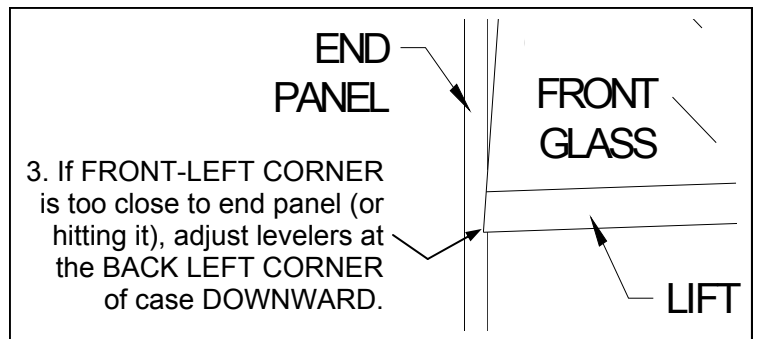
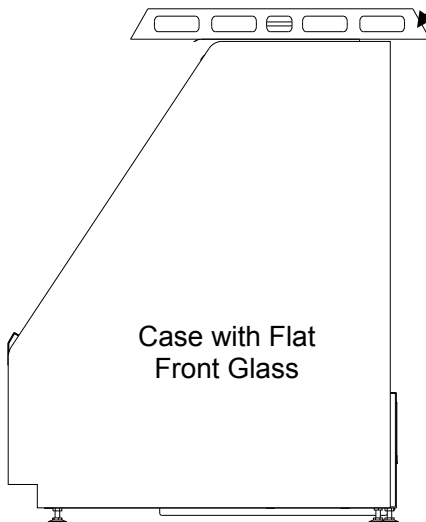
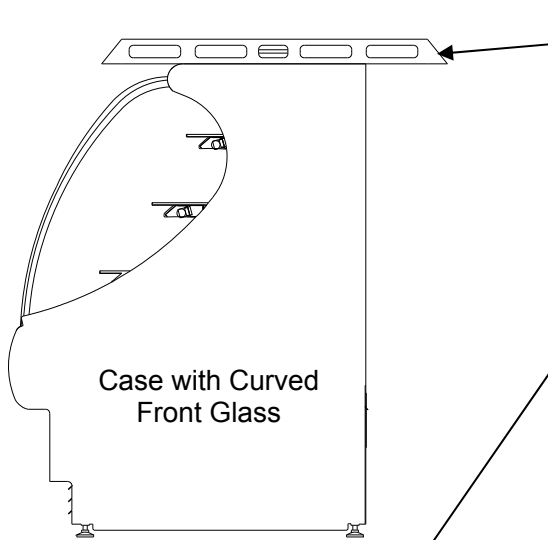
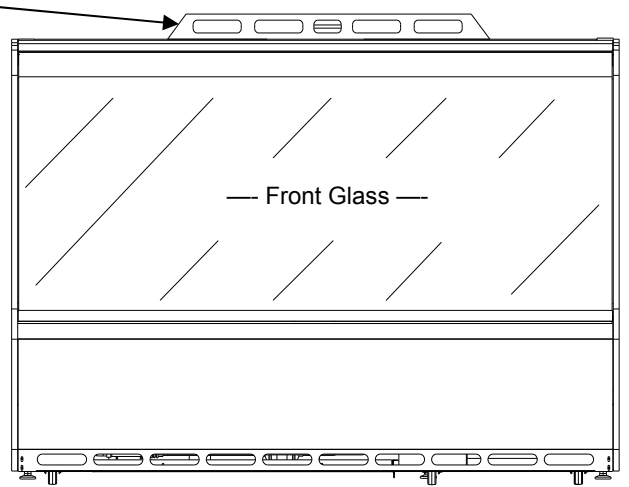

5. Verification: After inserting shims (or adjusting levelers), open and shut the front glass to confirm proper fit.

- Verify (again) that front glass is properly aligned at left-hand and right-hand side of the case.
- If not, repeat the shimming procedure (or leveler adjustment) until the front glass is properly aligned along both sides of the case.

11. Refrigeration Line Stub-Up Connections (Remote Units)

- Remove front panel.
- Refrigerant stub-up access opening is at the front on the left hand side of the base (see illustration at top-right).
- Stub-up connections are accessed from inside the case.
 - Remove interior ABS decks.
 - Remove fan shroud assembly.
- Line connections are in the tub front, on the left hand side
- Remove foam material from the entry hole provided in the tub drain trough.
- Route refrigerant lines through access hole.
 - Run case-to-case connections through cutouts in base.
 - Sweat the high and low pressure connections.
- Fill access hole with suitable filler to insure watertight integrity of tub.
- Illustration at top-right may not reflect every feature or option of your particular case.

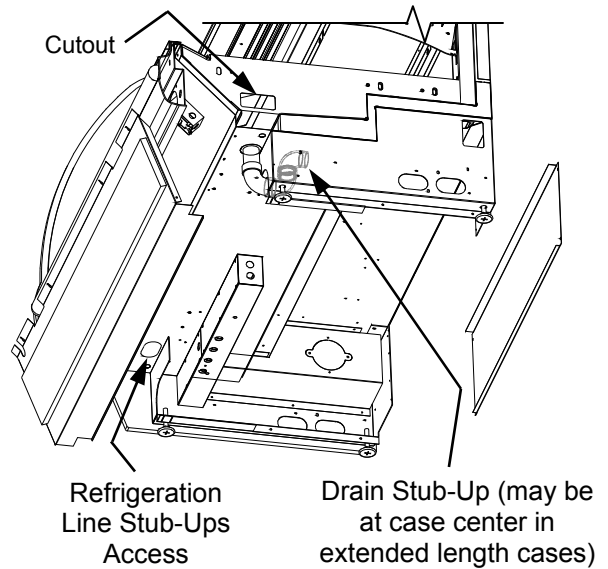

12. Refrigeration Drain Connection (Remote Units)

- Depending upon drain access needs, either front or rear panel may be removed to gain access to drain stub-up.
- 1.5" male PVC stub-up connection is under the case on the right hand side.
- Drain stub-up may be at case center in extended length cases.
- Connect tub drain to floor drain. Maintain 1/4"-fall per foot to provide proper drainage.
- Illustration at top-right may not reflect every feature or option of your particular case.

13. Evaporator Pan / Drain Position (Self-Contained Units)

- Remove the Rear Panel by lifting up & out.
- Slide the Condenser Unit out from case.
- Condenser Unit access is now available.
- Insure that the evaporator pan is installed under the PVC condensate drain trap.
- Insure that the evaporator pan is plugged into the receptacle inside base.
- Lower rear panel back into place.

- See ***Drain, Hose and Bracket Placement*** section in Operating Manual for details.

14. Electrical Wiring Diagram

- Each case has its own wiring diagram folded and in its own packet.
- Wiring diagram placement may vary; it may be placed near condenser fan cover, ballast box, raceway cover, or other related location.

15. Ventilation and Clearance

- **Self-Contained** refrigerated cases must maintain airflow clearance of 6" (minimum) to 12" (recommended) at front and rear.
- Restriction of air can void warranty.
- Illustration below may not reflect every feature or option of your particular case.

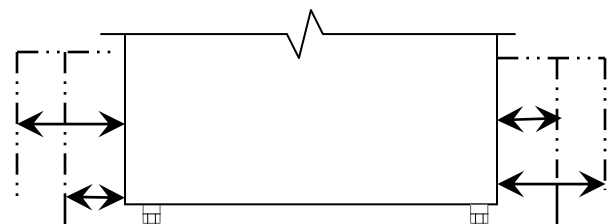

Check air grilles for obstructions. Maintain airflow clearance of 6" (min.) to 12" (recommended) at front & rear.

16. Display Case Start-Up

A. Case

- Turn main power on at case rear.
- From the front of the case, lift curved front glass by grasping lift handle and raising (see illustration at right).
- Lift deck to check that coil fans are running.
- Coil fans (and in self-contained units, compressor motor) should turn on.

B. Lights

- Turn lights on.
 - ⇒ Self-Contained Units: Switch is at rear.
 - ⇒ Remote Units [Standard]: NO SWITCH (lights will come on when main power switch is turned on).
 - ⇒ Remote Units [Optional]: Certain remote cases have switch that turns on lights.
- All lights should come on at the same time. If fluorescent bulbs (rather than LEDs), first time lighting may require a short warm-up period.
- Slightly dim / flickering of new bulbs is normal with fluorescent bulbs. If lights do not turn on, check raceway plugs.
- Lighting is wired in series so **all lights must be plugged in or receptacles capped** for case lights to be on. See illustration at right.
- LED Lights: If lights do not come on, check that plug is properly inserted into socket.

C. Temperature Controller (All Self-Contained Units and some Remote Units)

- Check that compressor symbol light is on.
- Compressor is identified with:



Compressor symbol (common in Carel® temperature controllers).

- After case has run for a few minutes, check that temperature starts to drop.
- If temperature controller does not begin cooling (in a few minutes) see temperature controller section in this operating manual for instructions.
- Remote units (without temperature controller on case): Verify that refrigeration requirements listed on serial label (found on the case) are being met.

D. Saturated Suction Temperature (Remote Units)

- See serial label on case for suction temperature requirements and BTU requirements.
- See serial label on case for defrost schedule and

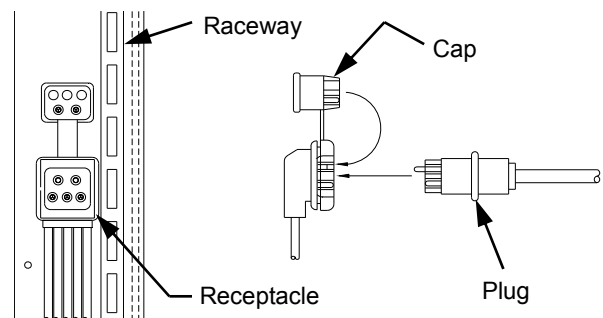
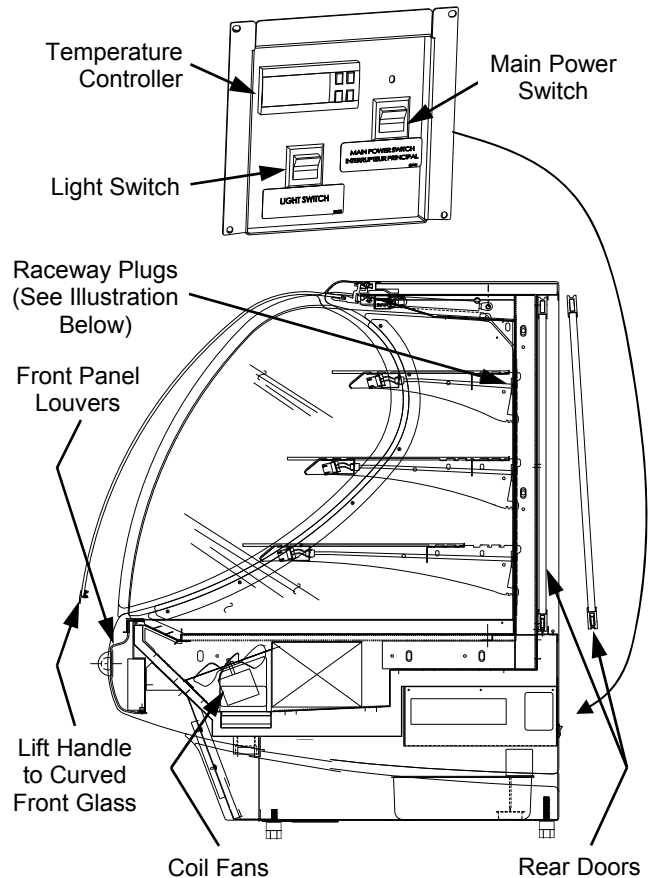

Raceway Receptacle, Plug and Cap

temperature termination parameters.



Sample Carel® Controller Face

OPTIONAL NIGHT AIR CURTAIN INSTALLATION & OPERATING INSTRUCTIONS - HVK MODELS

Night Air Curtain Installation & Operating Instructions

1. Use caution when handling Night Air Curtain.
2. Display case may come with Night Curtain already attached. If not, a retrofit kit will be provided. If using SCC-supplied retrofit kit, place night curtain on top of case as shown. Mark "keyslot" locations using night curtain as a template (you may have to retract the curtain from housing to reveal "keyslots". Drill $\text{Ø}11/32$ " holes in top board $1/2$ " deep. Press the "finserts" (shown below) into holes. Carefully tap in with flat object to prevent top board damage. Attach Night Air Curtain with #10-32 screws.
3. Grasp the handle and pull downward to desired location OUTSIDE acrylic sneeze guard (see illustration below).
4. To return Night Air Curtain to its retracted position, grasp handle, lift up and away from its magnetic attachment and carefully wind Night Air Curtain back into roll.
5. Caution! Do not allow spring-loaded Night Air Curtain to freely snap back into roll. Doing so can eventually destroy Night Air Curtain's tension and retractability.
6. To entirely detach Night Air Curtain from case, retract curtain (to access keyslots), remove screws. Lift Night Air Curtain upward and away from case.

NOTE: THE BELOW ILLUSTRATION MAY NOT EXACTLY REFLECT EVERY PARTICULAR CASE'S FEATURES OR OPTIONS.

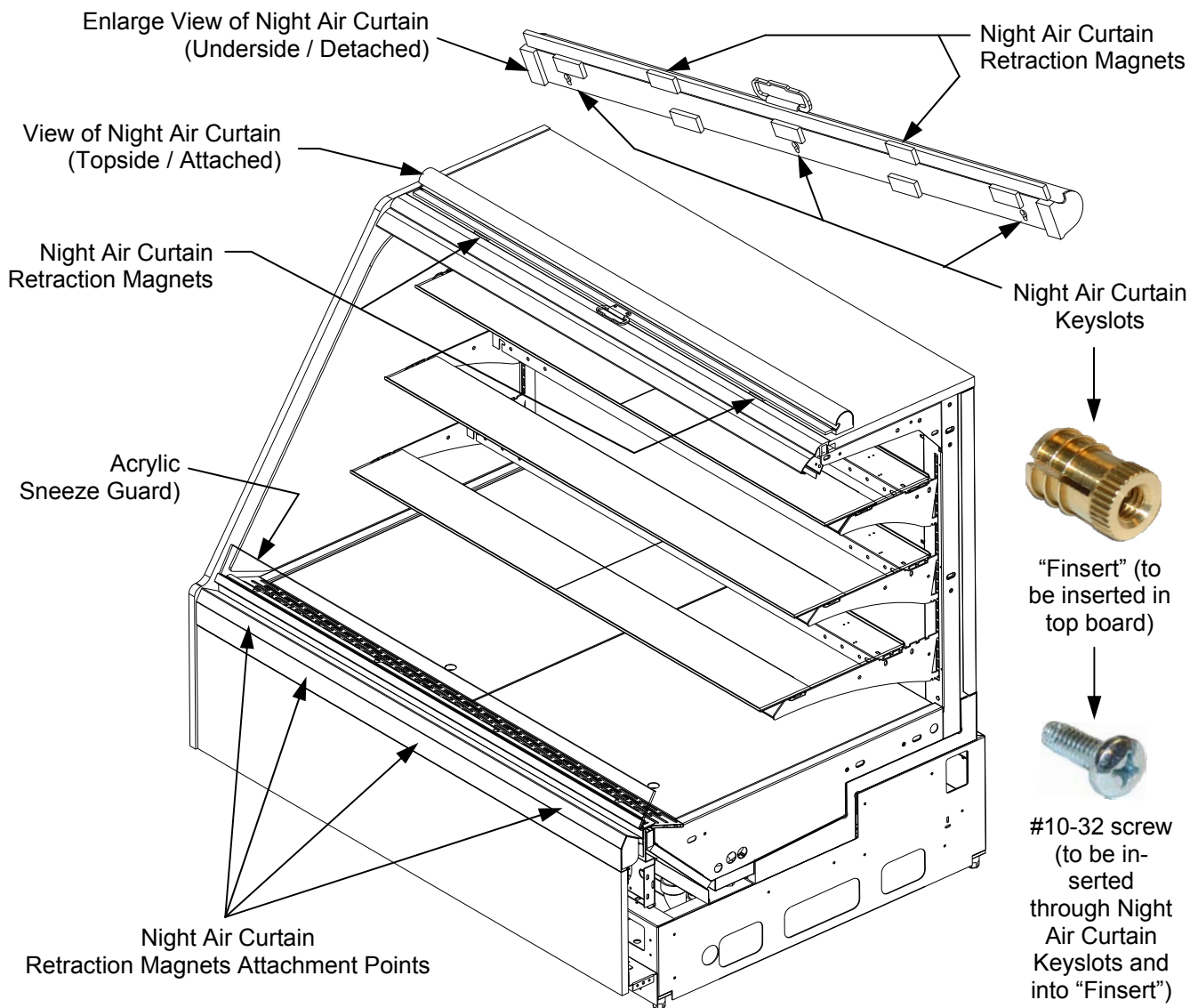

DRAIN, HOSE AND BRACKET PLACEMENT ILLUSTRATIONS

NOTE: BELOW ILLUSTRATIONS MAY NOT EXACTLY REFLECT EVERY PARTICULAR CASE'S FEATURES

Three Evaporator Systems Are Illustrated Below:

Illustration #1: Hot Gas "CopeVap" Evaporator System. "Copevap" is built into Compressor Unit.

Illustration #2: Hot Gas Evaporator System.

Illustration 3A/3B: Electrical Heat Rod Evaporator System. **Note:** Separate Evaporator Pan.

Warning! Regardless of Evaporator, the Hose and Drain Trap **MUST BE** secured and positioned over Evaporator Pan to prevent water seepage / spillage. When sliding out Condenser Unit, be careful that drain is not pulled from proper position.

2. Hot Gas Evaporator System.

- Hot gas serpentine coil is routed through a condensate reservoir allowing water to be heated. This system uses a wicking material (partially submersed) with warm condenser air passing through it for evaporation.
- Also incorporates an overflow reservoir with heating element to ensure complete condensate removal.

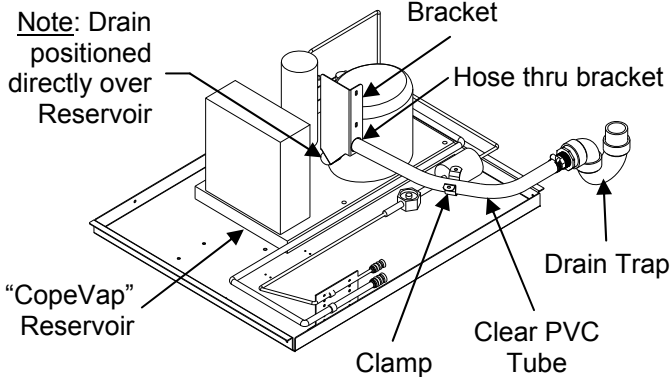
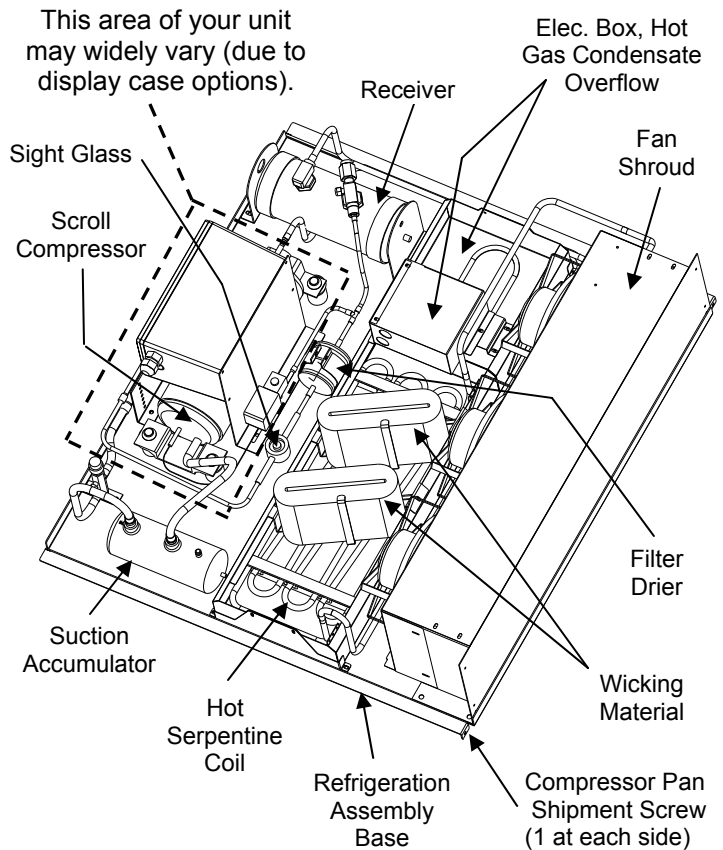

1. Hot Gas "CopeVap" Evaporator System.

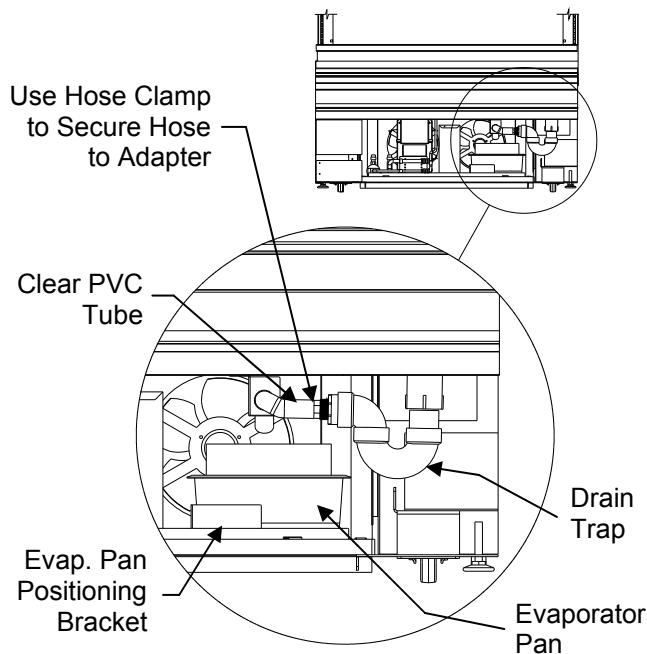

3A. Front View of Electrical Heat Rod Evaporator System

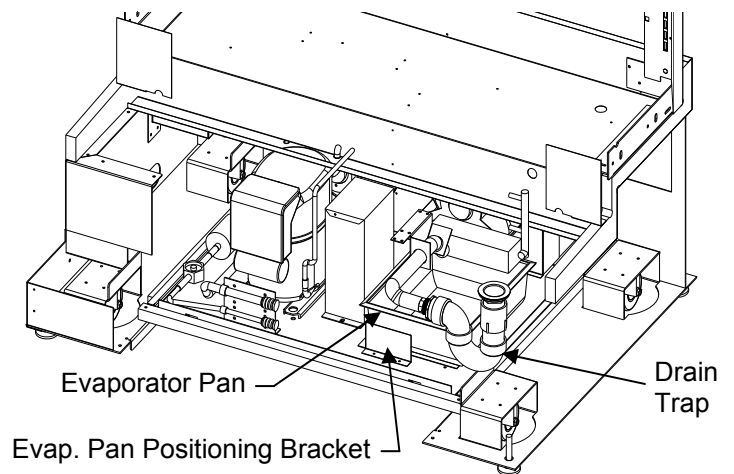

3B. Isometric View of Electrical Heat Rod Evaporator System

Note: See Installation section in this manual for:

- **Front Panel adjustment and removal**
- **Angled Base adjustment and removal**
- **Vertical Base adjustment and removal**

Light Fixtures

Warning! Disconnect power before providing maintenance and service to unit.

Caution: Lamps have been treated to resist breakage and must be replaced with similarly treated lamps.

Note: Warranty will be void if claims arise from negligence, misuse of goods, extreme environmental conditions or improper maintenance. See Overview And Warnings section in this operating manual.

Light fixtures are located on underside of shelf assemblies and at the top inside of case. See illustration at top-right for locations.

Removal of lamp:

- Rotate lamp (1/4-turn) either direction to disengage (upper or lower) pins/contacts from lamp-mounting sockets.
- Remove bulb by applying even pressure from back side at the bulb ends and pulling the remaining contact from sockets.
- See illustrations at mid and lower-right.

Installation of lamp:

- Align pins with slot.
- Insert pins into socket by rotating the bulb 1/4-turn to secure either the (upper or lower) pin contacts into the sockets.
- Rotate remaining bulb contacts (1/4-turn) into remaining lamp mounting socket contacts.
- See illustrations at right.

See next page for LED Light Fixture information

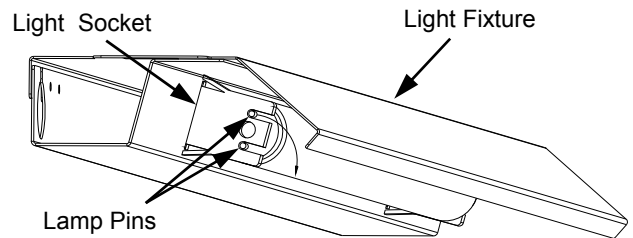
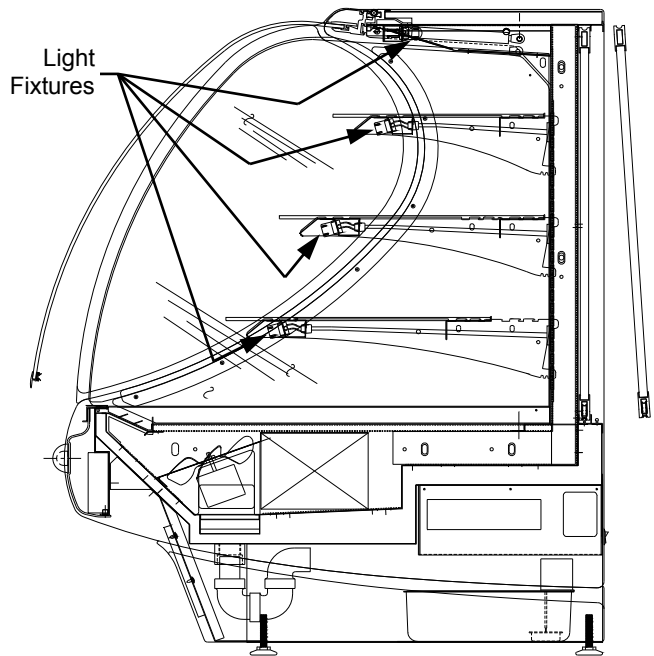

LED light removal / replacement:

- LED lights rarely require change-out.
- Contact Structural Concepts' Technical Service Department for replacement parts (see Technical Service section of this guide).
- To remove LED light fixture, disconnect existing LED light from its brackets & self-adhesive tape.
- Then, firmly grasp LED light while applying outward pressure to brackets.
- Twist the LED away from the bracket to release.

Plug and cord positioning:

- Plug is to connect to LED light at raceway side of case.
- Before attaching LED light to case, plug must connect to LED properly without cord doubling-back.
- See photos of proper vs. improper connections.

Proper plug insertion into LED light:

- Plug must be inserted into LED light properly or the LED will not light up.
- Oval form of plug is to connect to LED light oval form.
- See illustration at right.

See previous page for Standard Light Fixture information.

Bracket Retainer Removal

- To remove brackets, it may be necessary to remove the nylon shipping bracket retainers.
- Pliers will be required to accomplish this task.
- See illustration at top-right for location of bracket retainers.

Shelf Assembly Removal

- Remove glass shelves
- For lighted shelving, unplug the light cord.
- Remove rear shelf support.
- Remove shelf light cover from brackets.
- Lift brackets up and out.

Drain and Expansion Valve Access

- The drain and expansion valve are both accessible from the front of the case.
- Unplug the fans (one plug per side) and remove the fastener from the access panel in the front right (or left) corner of the unit.
- The drain and the expansion valve (TXV) are directly below the access panel.

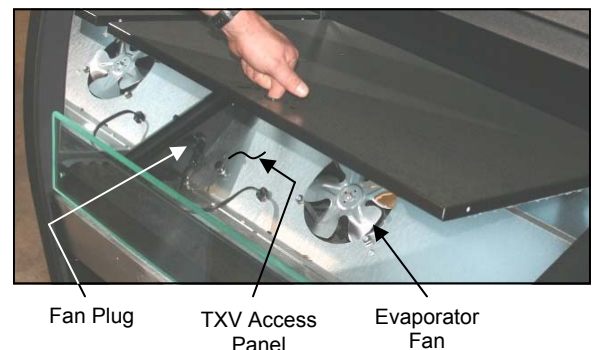
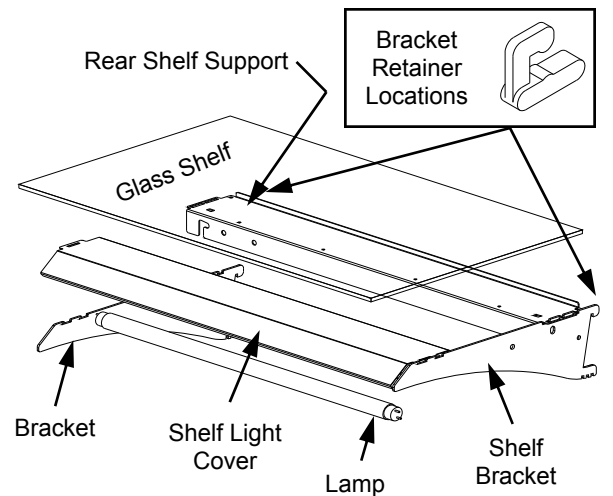
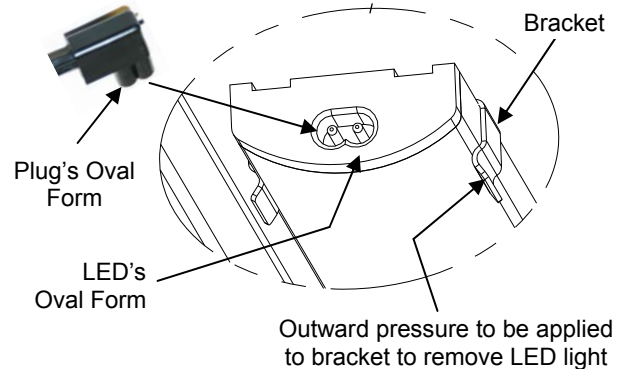
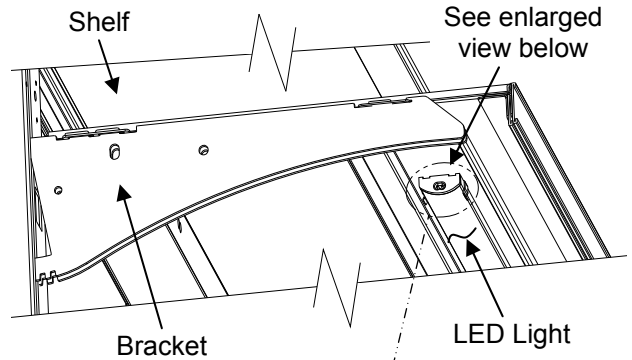

Refrigeration Package Access

Note: Servicing to be accomplished by licensed electrical / refrigeration contractor.

Air Filter

- Magnetic strips attached to the filter adhere the filter to the rear grille.
- Clean the nylon mesh filter by rinsing thoroughly with water against the air flow direction.
- Mild detergent removes smoke & grease stains.
- See illustration at top-right.

Pull Out Refrigeration Package

- Remove the rear grille. Grille may be slid upward and out or removal of two screws may be required.
- **Note:** At initial slide-out, it may be necessary to remove Compressor Pan Shipment Screws (see illustration at right for location).
- *Refrigerant lines are flexible to facilitate rear access maintenance.*
- Plastic glides are mounted at base to assist in sliding the condenser out for access.
- Service connections are at the left of compressor.
- Slide condenser unit out 12 to 18 inches to access high pressure service connection.

Temperature Controller (Self-Contained Units Only)

- Temperature Controller is located in the Ballast Box.
- Temperature / Defrost control settings are programmable from these locations.
- Case Temperature Set Point is set at the factory, as determined by case size & sensor probe location.
- Temperature is controlled by thermostat.
- If a temperature setting change is required, follow instructions regarding Temperature Control Programming Steps in the technical information section of this operating manual.
- If service is required to the temperature control unit, call Structural Concepts Corporation. Maintenance should be performed by a certified technician.
- The toll-free number is listed in the Technical Service section of this manual.
- See Temperature Controller section in this manual.

NOTE: Spirit-filled thermometers located in the refrigerated compartment are for monitoring warmest air temperature in accordance with NSF Std. 7

Evaporator Pan Access / Removal

- Turn off main power; allow evaporator pan to cool.

The illustration below may not depict an exact representation of your particular unit.

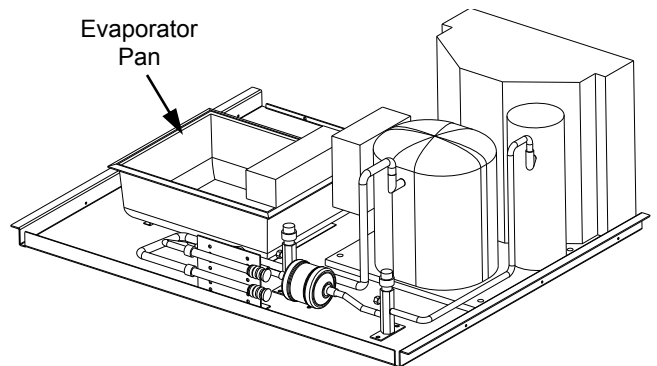
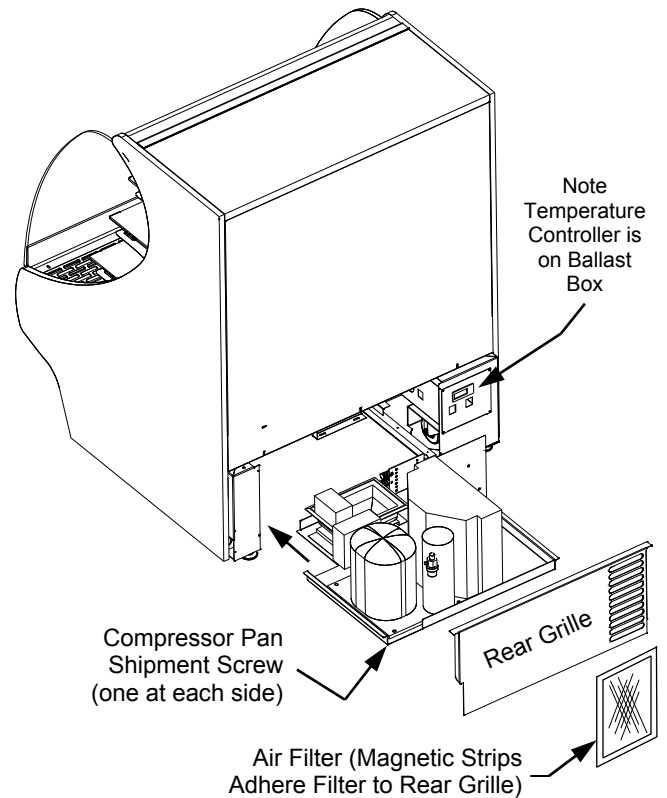

Note: Illustration shown may not exactly reflect your case's refrigeration package layout.

- Lift Rear Grille up and off (no tools required).
- **WARNING! Evaporator Pan May Be Hot!** Check temperature of pan prior to handling.
- Withdraw evaporator pan from the right side behind electrical box.
- Unplug evaporator pan from the electric outlet.
- Empty evaporator pan contents into suitable container. Replace rear panel when completed.

MAINTENANCE FUNDAMENTALS - REAR SLIDING DOORS

Removing the Rear Sliding Doors

Note: Doors are not interchangeable. There is an inner and outer door. The outer must be removed first and replaced last.

- The outer door is the right hand door (from the service side or rear of case).
- It is identified by a stop located at the lower right hand corner to the inside of the case.
- Move doors toward the center of the case.
- Individually lift each door up toward the top of the case; pivot the bottom of the door out.
- Carefully set rear sliding doors down to prevent them from falling.
- Replace rear sliding doors in reverse order they were removed.

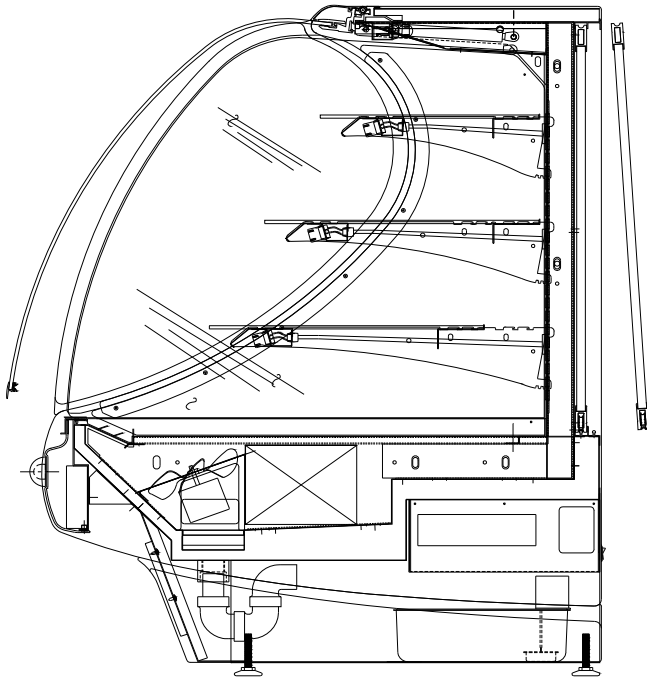

Case With Single Set of Rear Sliding Doors

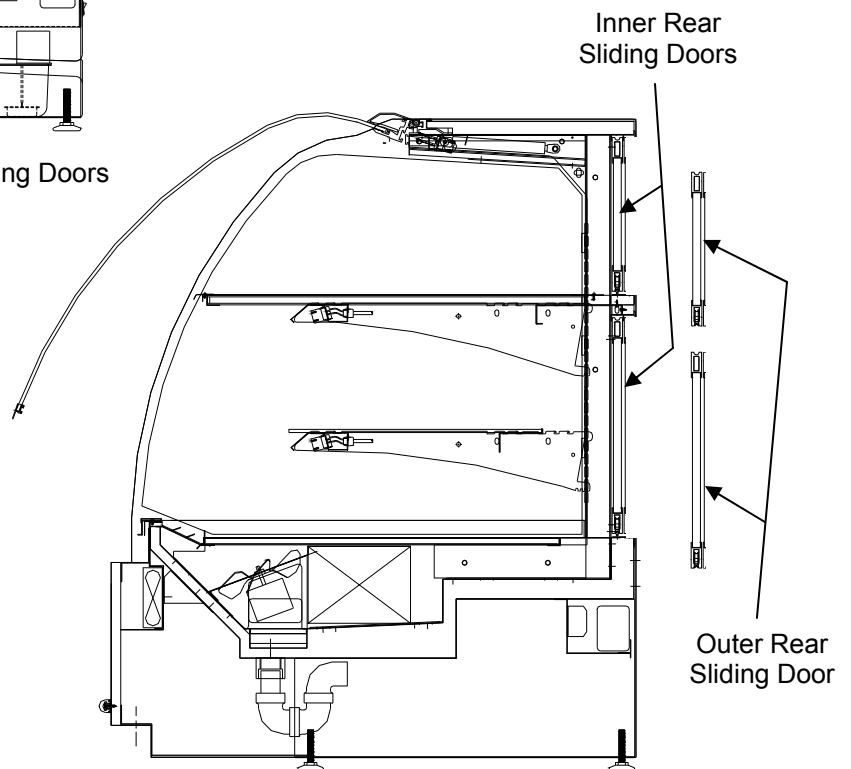

Case With Double Set of Rear Sliding Doors

CLEANING SCHEDULE - TO BE PERFORMED BY STORE PERSONNEL

AREA	FREQ.	INSTRUCTIONS
Exterior	Daily	All Glass / Mirrors: Clean side glass, front glass, glass shelves, and mirrors with household or commercial glass cleaner. Clean out door track with moist cloth.
	Daily	Rear Sliding Door Exterior Glass: Clean with household or commercial glass cleaner.
	Daily	End Panels, Front Panel, Toe-Kick, etc.: Wipe off all surfaces with warm water and mild soap solution and non-abrasive cloth.
	Weekly	Wood, Laminate and Painted Surfaces: Clean with mild soap and water solution and a soft cloth .
	Weekly	Acrylic: Clean with warm water, mild soap solution and soft cloth; acrylic cleaning solutions are also available. Caution! Never use ammonia-based cleaners on acrylic. Incorrect cleaning agents or abrasive cleaning cloths cause surface to 'cloud' over time.
	Weekly	Air Filter (with Magnetic Strips) on Rear Grille: Remove air filter. Rinse with hot water against air flow direction. Use mild detergent to remove smoke and grease stains.
	Monthly	Condensing Coil: Remove rear grille. Vacuum or brush grille area on back of case; clean dust and dirt collecting on condenser coil. Avoid damaging fins.
	Monthly	Under Case Cleaning: Remove front toe-kick (or rear grille). Vacuum under case to remove all dust and dirt. Replace front toe-kick (or rear grille) when complete.
Interior	Weekly	Decks: Wipe off decks with moist cloth dipped in mild soap and water solution.
	Monthly	Tub and Drain: Keep clean and free of debris which could clog tub and drain. To access drain area, remove the deck and fan shroud. <ul style="list-style-type: none"> • Vacuum tub under deck. • Direct the drain to a floor drain or a bucket. • Run hose into drain to flush out debris. Carefully hose out the tub. • Caution! Avoid splattering water over the case and surrounding areas!
	Monthly	Air Return Grille and Fan Shroud Area: 1) Turn off power. 2) Remove decks from case. 3) Clean with moist cloth.

CONDITION	TROUBLESHOOTING
Case Not Lining Up	See Installation Section for instructions on properly aligning case (alongside other cases) and adjusting levelers.
Water Is On The Floor	<p>Caution! Water on flooring can cause much damage! Until cause is determined (and repaired), following these procedures:</p> <ul style="list-style-type: none"> • Use wet-dry vacuum (or mop & bucket) to remove standing water. • Use 'catch pans' for water to drain into. Swap out regularly until case has completely drained. <p>Note: See <i>Drain, Hose and Bracket Placement Illustrations</i> sheet in this manual for views of different evaporator systems used in display cases.</p>
	Check that the drain trap is free of debris.
	Check that the drain hose is correctly positioned over evaporator pan (or floor drain, for remote units).
	Check store conditions. To prevent condensation in NSF® Type 1 environments, maximum conditions are to be 55% humidity / 75° Fahrenheit. For NSF® Type 2, maximum conditions are to be 60% humidity / 80° Fahrenheit. See serial label (at case rear near main power switch) for NSF® Type of your case.
	Check evaporator pan float for proper operation (Heat Rod Evaporator System only).
	Check that evaporator pan is plugged in.
	<p>Caution! Evaporator pan may be malfunctioning (Electrical Heat Rod Evaporator system). If so, water will overflow pan and seep onto flooring causing damage! Until evaporator pan is functioning (or is replaced), following these procedures:</p> <ul style="list-style-type: none"> • Use wet-dry vacuum (or mop & bucket) to remove standing water. • Use 'catch pans' for water to drain into. Swap out regularly until case has completely drained.
	<p>Caution! Disruption of power can cause water to overflow pan and seep onto flooring causing damage! Check that power to case is constant. Until power is restored, following these procedures:</p> <ul style="list-style-type: none"> • Use wet-dry vacuum (or mop & bucket) to remove standing water. • Use 'catch pans' for water to drainage. Swap out regularly until evaporation of case is complete (or until power is restored). <p>When power to case is restored, evaporator pan should function properly and water will no longer overflow onto flooring.</p>
	<p>Wicking material may be dirty or worn and need replacement (Hot Gas Evaporator system).</p> <ul style="list-style-type: none"> • Slide refrigeration system out from under unit. • After refrigeration system has been carefully slid out from under unit, replace wicking material with new. If wicking material is not available, contact Structural Concepts®. See toll-free number at last page of this operating manual.

CONDITION	TROUBLESHOOTING
Fan Emits Excessive Noise	Check that the case is aligned, level and plumb.
	Check evaporator fan for cleanliness.
	Unplug fan motors; check motor shaft for excessive bearing wear.
	Check that fan motors are securely mounted in brackets.
	Verify that fan blades are securely mounted to fan motor.
	Check that nothing is preventing blade rotation.
	Check that the fan shroud is properly secured.
Fans Are Not Working	Check that the MAIN power switch (if present) is on.
	Check that fans are plugged in to fan shroud.
	Check for foreign material obstructing fan performance.
	Check that fan blades freely rotate within fan shrouds.
	Check that power is going to fans.
	Check that fan wiring is connected on terminal blocks.
System Is Not Operating	Check that the utility power is on.
	Check the circuit breaker box for tripped circuits.
Case Is Not Holding Temperature	If a large amount of warm product was added to the case, it will take time for the temperature to adjust. Product should be pre-chilled before placing in display case.
	Check Temperature Controller section in this manual.
	Check that the case is not in the sun or near a heat or air conditioning vent.
	If case is located near outside doors, temperature fluctuation can hinder unit's ability to maintain temperature.
	Check air grilles for obstructions. Maintain airflow clearance of 6" (minimum) to 12" (recommended) at case front and rear.
	Check sight glass for flashing and/or low charge.
	Check Set Point Temperature; it may be adjusted too high.

CONDITION	TROUBLESHOOTING
Case Lights Are Not Working	Check that Light switch is in the ON position (self-contained cases only). Remote case lights come on at start-up.
	Check for burned out bulbs. Turn lights off & replace.
	Clean dirt and dust from the bulbs to prevent flickering.
	Check to insure voltage at ballasts. If voltage is entering but not exiting the ballast, ballast is faulty.
	Check that ALL lights are plugged in and receptacles capped.
	See MAINTENANCE FUNDAMENTALS - LED LIGHT FIXTURES section in this manual for illustrations.
Control Display Is Flashing	Check Temperature Controller section in this manual.
Condensing Unit Is Not Operating (Self-Contained Units Only)	Check Temperature Controller section in this manual.
	Check that the power is turned on.
	Review Temperature Controller's Settings for accuracy.

TROUBLESHOOTING - CONDENSING SYSTEM (QUALIFIED SERVICE TECHNICIANS ONLY)

CONDITION	TROUBLESHOOTING
Head Pressure Too High	Check that the Condensing Coil is not dirty or covered.
	Check that Condensing Fans are working.
	Check that the refrigeration system is not overcharged.
	Check that case is free of non-condensables.
	Check that the Liquid Line Drier Filter is not plugged.
	Check Set Point temperature; it may be adjusted too high.
	Check System Operating temperatures.
	Check that Store Ambient temperature isn't above maximum allowed. See <i>Overview and Warnings</i> Section.
Head Pressure Too Low	Check that Refrigerant Charge isn't too low.
	Check that Suction Pressure isn't too low.
	Check to verify that Compressor Valves aren't faulty.

TROUBLESHOOTING - EVAPORATOR SYSTEM (QUALIFIED SERVICE TECHNICIANS ONLY)

CONDITION	TROUBLESHOOTING
Low Suction Pressure	Check for low refrigerant.
	Check that Expansion Valve isn't restricted.
	Check that Liquid Line or Filter isn't restricted.
	Check that Evaporator Motors are working.
	Check for Superheat setting.
	Check that the Thermostatic Element charge isn't depleted.
	Check that the Coil is not iced up.
High Suction Pressure	Check that Refrigerant Charge isn't too high.
	Check that Compressor Valves aren't faulty.
	Check that there is no air seepage around Condensing Coil.
	Check that the Cooling Load isn't high.
	Check that Superheat adjustment isn't low.
	Check TXV Bulb Installation <ul style="list-style-type: none"> a. Poor thermal contact. b. Warm location.
	Check Compressor: Low capacity means it is undersized for its application.

PREVENTIVE MAINTENANCE (TO BE PERFORMED BY TRAINED SERVICE PROVIDER)

WARNING! TURN OFF CASE BEFORE PERFORMING PREVENTIVE MAINTENANCE!

PREVENTIVE MAINTENANCE	FREQUENCY	INSTRUCTIONS
Case Exterior	Monthly	<p><u>Condensing Coil:</u></p> <ul style="list-style-type: none"> • Remove Rear Grille (by removing 4 screws). • Use air pressure or industrial strength vacuum; clean dust and dirt that may collect on the Condenser Coil. See illustration below. • Caution! Coil fins are sharp. Handle with care! • Replace Rear Grille to case (4 screws).
	Quarterly	<p><u>Evaporator Pan:</u> <i>Caution! Disconnect from receptacle box.</i></p> <ul style="list-style-type: none"> • Remove mounting screws from base. • Use de-scaling solution (such as CLR® that will prevent corrosion, lime and rust) to clean pan. • Rinse thoroughly; do not submerge in water. • Reattach pan to case with same mounting screws. • Reconnect power cord to receptacle box.
	Quarterly	<p><u>Compressor Area:</u> <i>Caution! Be certain to disconnect power from case before cleaning Compressor Area!</i></p> <ul style="list-style-type: none"> • Slide/Roll compressor package out from under case. • Use moist cloth to wipe off dust & debris that collects on various parts. • Slide/Roll compressor package back under case.
	Quarterly	<p><u>Under Case Cleaning:</u> Once refrigeration package is clear of unit, vacuum under case to remove all dust and dirt that may collect under case.</p>
Case Interior	Quarterly	<p><u>Tub, Coil, Drain, Fan Blades, Motors, Brackets:</u> <i>Disconnect power from the case before cleaning the Tub, Coil, Fan, Motor and Drain Area!</i></p> <ul style="list-style-type: none"> • Remove Decking, Sub-Deck and Fan Shroud. • Use vacuum to clean Evaporator Coils. • Clean Tub, Coil and Drain with warm water, clean cloth, brush and mild soap solution. • Remove any debris that may clog drain. • Clean Fan Blades, Motors and Brackets by wiping down with moist cloth.

Serial Label Location & Information Listed / Technical Information & Service

- Serial labels are located near the electrical access on your case.
- Serial labels contain electrical, temperature & refrigeration information, as well as regulatory standards to which the case conforms.
- For additional technical information and service, see the *TECHNICAL SERVICE* page in this manual for instructions on contacting Structural Concepts' Technical Service Department.
- See images below for samples of both refrigerated and non-refrigerated serial labels.



888 E. Porter Rd · Muskegon, MI 49441

ENCORE[®] MODEL HV74RSS SCROLL
SERIES SERIAL NO.

FOR PARTS AND SERVICE
CALL 1-800-433-9489



3048256
CONFORMS TO UL STD 471
CONFORMS TO NSF STD 7
CERTIFIED TO CAN/CSA
STD C22.2 NO 120

ELECTRICAL RATING 120/1/60 24A
REFRIGERANT R404A AMOUNT ?? OZ
DESIGN PRESSURE HIGH 450 LOW 200
MINIMUM CIRCUIT 30A
MAXIMUM OVERCURRENT 30A

SAMPLE ONLY

Super Heat Temp 8-10°F
BTUH Requirements 9,738 BTUH @ 20° F SST
Defrost 6 defrosts per day, 45° F termination, 45 min. failsafe

SAMPLE ONLY

SAMPLE ONLY

----- Sample Serial Label For Refrigerated Case -----



888 E. Porter Rd · Muskegon, MI 49441

Addenda[®] PC5682 txtRemote
txtSerialNumber

120 VOLTS 60 HZ SINGLE PHASE 1.84AMP

FOR PARTS OR SERVICE CALL
STRUCTURAL CONCEPTS
AT
1-800-433-9489



3048256
CONFORMS TO UL STD 65
CERTIFIED TO CAN/CSA
STD C22.2 NO 120

SAMPLE ONLY

N/A

----- Sample Serial Label For Non-Refrigerated Case -----

CAREL

ir33 platform

Integrated Electronic
Microprocessor Controller



Programming The Instrument

To Modify The Setpoint

Set Press and hold the "SET" key for at least 1 second.

▲/aux **def/▼** 2. Use arrow keys ▲ ▼ on temperature controller to increase (or decrease) the setpoint.

Set 3. Quickly press and release the "SET" key again.

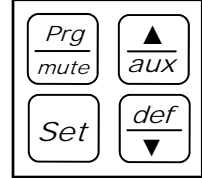

To Modify Defrost, Differential or Other Parameters

Prg/mute **Set** 1. Press & hold "Prg" & "SET" keys together for five (5) seconds; display will flash "0", representing password prompt.

Set 2. Confirm by pressing "SET" key.

▲/aux **def/▼** 3. Press ▲ or ▼ to reach the category to be modified.

Set 4. Press "SET" to modify this selected parameter.

▲/aux **def/▼** 5. Increase or decrease the value using the ▲ or ▼ button respectively.

Set 6. Press the "SET" key to temporarily save the new value and return to the display of the parameter.

Prg/mute 7. Press & hold the "Prg" key for at least 5 seconds to save changes. This action will also mute the audible alarm (buzzer) & deactivate the alarm relay.

How To Change Reading From Fahrenheit (°F) To Celsius (°C)

Prg/mute **Set** 1. Press and hold "Prg" and "SET" keys together for at least 5 seconds; display will show "0", representing password prompt.

Set 2. Confirm by pressing "SET" key.

▲/aux **def/▼** 3. Press ▲ or ▼ until reaching the parameter "15".

Set 4. Press "SET" to modify this selected parameter.

▲/aux **def/▼** 5. Press ▲ or ▼ to change value to desired setting: "0" for Celsius (°C) or "1" for Fahrenheit (°F).

Set 6. Press "SET" key to temporarily save the new value and return to the display of the parameter.

Prg/mute 7. Press & hold "Prg" key for at least 5 seconds to save changes. **Note! All values will automatically convert to new scale. No conversion is required.**

Warning! Save Your Parameter Settings!

1. To store the new parameter values, PRESS and HOLD the "Prg" key for at least 5 seconds.
2. All modifications made to parameters will be lost if you do NOT press a button within 60 seconds. Should this "timeout" occur, normal operational settings (prior to modifications being made) will resume.
3. If the instrument is switched off before pressing the "Prg" key, all modifications to parameters will be lost.

def/▼ **To Activate Manual Defrost**
Press and hold the "def" key for at least 5 seconds.

▲/aux **To Activate / Deactivate Auxiliary Output**
Press and hold the "aux" key for 1 second.

Prg/mute **▲/aux** **To Reset Any Alarms With Manual Reset**
Press and hold the "Prg" and "aux" key for at least 1 second.

CAREL

ir33 platform
**Integrated Electronic
 Microprocessor Controller**



User Interface - Display

ICON	FUNCTION	DESCRIPTION	ON	Normal operation OFF	BLINK	Start up
	COMPRESSOR	ON when the compressor starts. Flashes when the activation of the compressor is delayed by safety times.	Compressor on	Compressor off	awaiting activation	
	FAN	ON when the fan starts. Flashes when the activation of the fan is prevented due to external disabling or procedures in progress.	Fan on	Fan off	awaiting activation	
	DEFROST	ON when the defrost is activated. Flashes when the activation of the defrost is prevented due to external disabling or procedures in progress.	Defrost in progress	Defrost not in progress	awaiting activation	
	AUX	Flashes if the anti-sweat heater function is active, ON when the auxiliary output (1 and/or 2) selected as AUX (or LIGHT in firmware version 3.6) is activated.	AUX auxiliary output active (version 3.6 light auxiliary output active)	AUX auxiliary output not active	Anti-sweat heater function active	
	ALARM	ON following pre-activation of the delayed external digital input alarm. Flashes in the event of alarms during normal operation (e.g. high/low temperature) or in the event of alarms from an immediate or delayed external digital input.	Delayed external alarm (before the time 'A7' elapses)	No alarm present	Alarms in norm. operation (e.g. High/low temperature) or immediate or delayed alarm from external digital input	
	CLOCK	ON if at least one timed defrost has been set. At start-up, comes ON for a few seconds to indicate that the Real Time Clock is fitted.	If at least 1 timed defrost event has been set	No timed defrost event set	Alarm clock	ON if real-time clock present
	LIGHT	Flashes if the anti-sweat heater function is active, ON when the auxiliary output (1 and/or 2) selected as LIGHT is activated (in firmware version 3.6 it does not flash in anti-sweat heater mode and comes on when the dead band output is active).	Light auxiliary output on (version 3.6 dead band auxiliary output active)	Light auxiliary output off	Anti-sweat heater function active (version 3.6 does not flash in anti-sweat heater mode)	
	SERVICE	Flashes in the event of malfunctions, for example E2PROM errors or probe faults.		No malfunction	Malfunction (e.g. E2PROM error or probe fault). Contact service	
	CONTINUOUS CYCLE	ON when the CONTINUOUS CYCLE function is activated. Flashes if the activation of the function is prevented due to external disabling or procedures in progress (E.g.: minimum compressor OFF time).	CONTINUOUS CYCLE operation activated	CONTINUOUS CYCLE function not activated	CONTINUOUS CYCLE operation requested	

Summary Table of Alarm and Signals: Display, Buzzer and Relay

Code	Icon on the display	Alarm relay	Buzzer	Reset	Description
rE	flashing	on	on	automatic	virtual control probe fault
E0	flashing	off	off	automatic	room probe S1 fault
E1	flashing	off	off	automatic	defrost probe S2 fault
E2	flashing	off	off	automatic	probe S3 fault
E3	flashing	off	off	automatic	probe S4 fault
E4	flashing	off	off	automatic	probe S5 fault
'	No	off	off	automatic	probe not enabled
LO	flashing	on	on	automatic	low temperature alarm
HI	flashing	on	on	automatic	high temperature alarm
AFr	flashing	on	on	manual	antifreeze alarm
IA	flashing	on	on	automatic	immediate alarm from external contact
dA	flashing	on	on	automatic	delayed alarm from external contact
dEF	on	off	off	automatic	defrost running
Ed1	No	off	off	automatic/manual	defrost on evaporator 1 ended by timeout
Ed2	No	off	off	automatic/manual	defrost on evaporator 2 ended by timeout
Pd	flashing	on	on	automatic/manual	maximum pump down time alarm
LP	flashing	on	on	automatic/manual	low pressure alarm
AtS	flashing	on	on	automatic/manual	autostart in pump down
cht	No	off	off	automatic/manual	high condenser temperature pre-alarm
CHT	flashing	on	on	manual	high condenser temperature alarm
dor	flashing	on	on	automatic	door open too long alarm
EE	flashing	off	off	automatic	E2prom error, unit parameters
EF	flashing	off	off	automatic	E2prom error, operating parameters
ccb	Signal				start continuous cycle request
ccE	Signal				end continuous cycle request
dFb	Signal				start defrost call
dFE	Signal				end defrost call
On	Signal				switch ON
off	Signal				switch OFF
rES	Signal				reset alarms w/manual reset / reset HACCP alarms / reset temp. monitoring

CAREL

ir33 platform
 Integrated Electronic
 Microprocessor Controller



Summary Table of Operating Parameters

CODE	PARAMETER	UOM*	TYPE	MINIMUM	MAXIMUM	DEFAULT
/5	Select Celcius (°C) or Fahrenheit (°F)	flag	C	0	1	For Case Specific Defaults See Serial Label Located Near Electrical Access On Your Case. For Additional Technical Information Call Structural Concepts Technical Service Dept. at 1(800) 433.9489
/c1	Calibration of probe 1	°C/°F	C	-20	20	
/c2	Calibration of probe 2	°C/°F	C	-20	20	
St	Temperature set point	°C/°F	F	r2	r1	
rd	Control delta	°C/°F	F	20	0.1	
dl	Interval between defrosts	hours	F	0	250	
dt1	End defrost temperature, evaporator	°C/°F	F	-50	200	
dP1	Maximum defrost duration, evaporator	min	F	1	250	
d6	Display on hold during defrost	-	C	0	2	
dd	Dripping time after defrost	min	F	0	15	
d/1	Display of defrost probe 1	°C/°F	F	-	-	

* Unit Of Measure

STRUCTURAL CONCEPTS CORPORATION TECHNICAL SERVICE
PHONE NUMBER: 1.800.433.9489 or For Your Master Service Agent See
WWW.STRUCTURALCONCEPTS.COM/Contact/Master_Service_Agents.asp

WARRANTY INFORMATION

(Note: Standard Limited Warranty can be found at www.StructuralConcepts.com)

All sales by Structural Concepts Corporation (SCC) are subject to the following limited warranty. "Goods" refers to the product or products being sold by SCC.

Warranty Scope: Warranty is for equipment sold in the United States, Canada, Mexico and Puerto Rico. Equipment sold elsewhere may carry modified warranty.

Warranty; Remedies; Limitations. SCC warrants that if any Goods are found by an authorized representative of SCC not to be of good material or workmanship within one year of the date of shipments SCC will, at its option after inspection by an authorized representative, replace any defective Good or pay the reasonable cost of replacement for any such defective Goods, provided that written notice of the defect is given to SCC within 30 days of the appearance of such defect. If notice is not given within such period, any claim for breach of warranty shall be conclusively deemed to have been waived and SCC shall not be liable under this warranty. If SCC is unable to repair or replace the defective Goods, SCC shall issue a credit to the Purchaser for all or part of the purchase price, as SCC shall determine. The replacement or payment in the manner described above shall be the sole and exclusive remedy of Purchaser for a breach of this warranty. If any Goods are defective or fail to conform to this warranty, SCC will furnish instructions for their disposition. No Goods shall be returned to SCC without its prior consent.

SCC's liability for any defect in the Goods shall not exceed the purchase price of the Goods. SCC SHALL HAVE NO LIABILITY TO PURCHASE FOR CONSEQUENTIAL DAMAGES OF ANY KIND WHATSOEVER, INCLUDING, BUT NOT LIMITED TO, PERSONAL INJURY, PROPERTY DAMAGE, LOST PROFITS, OR OTHER ECONOMIC INJURY DUE TO ANY DEFECT IN THE GOODS OR ANY BREACH OF SCC. SCC SHALL NOT BE LIABLE TO THE PURCHASER IN TORT FOR ANY NEGLIGENT DESIGN OR MANUFACTURE OF THE GOODS, OR FOR THE OMISSION OF ANY WARNING THEREFROM.

SCC shall have no obligation or liability under this warranty for claims arising from any other party's (including Purchaser's) negligence or misuse of the Goods or environmental conditions. This warranty does not apply to any claim or damage arising for or cause by improper storage, handling, installation, maintenance, or from fire, flood, accidents, structural defects, building settlement or movement, acts of God, or other causes beyond SCC's control.

Except as expressly stated herein, SCC makes no warranty, express, implied, statutory or otherwise as to any parts or goods not manufactured by SCC. SCC shall warrant such parts or Goods only (I) against such defects, (II) for such periods of time, and (III) with such remedies, as are expressly warranted by the manufacturer of such parts of Goods. Notwithstanding the foregoing, any warranty with respect to such parts of Goods and any remedies available as a result of a breach thereof shall be subject to all of the procedures, limitations, and exclusions set forth herein.

THE WARRANTIES HEREIN ARE IN LIEU OF ALL WARRANTIES, EXPRESS, IMPLIED, STATUTORY, OR OTHERWISE. IN PARTICULAR, SCC MAKES NO WARRANTY OF MERCHANTABILITY OR FITNESS FOR A PARTICULAR PURPOSE.

No representative, agent or dealer of SCC has authority to modify, expand, or extend this Warranty, to waive any of the limitations or exclusions, or to make any different or additional warranties with respect to Goods.

Period of Limitations. No claim, suit or other proceeding may be brought by Purchaser for any breach of the foregoing warranty or this Agreement by SCC or in any way arising out of this Agreement or relating to the Goods after one year from the date of the breach. In the interpretation of this limitation on action for a breach by SCC, it is expressly agreed that there are no warranties of future performance of the goods that would extend that period of limitation herein contained for bringing an action.

Indemnifications. Purchaser agrees to indemnify, hold harmless, and defend SCC if so requested, from any and all liabilities, as defined herein, suffered, or incurred by SCC as a result of, or in connection with, any act, omission, or use of the Goods by Purchaser, its employees or customers, or any breach of this Agreement by Purchaser. Liabilities shall include all costs, claims, damages, judgments, and expenses (including reasonable attorney fees and costs).

Remedies of SCC. SCC's rights and remedies shall be cumulative and may be exercised from time to time. In a proceeding or action relating to the breach of this Agreement by Purchaser, Purchaser shall reimburse SCC for reasonable costs and attorney's fees incurred by SCC. No waiver by SCC of any breach of Purchaser shall be effective unless in writing nor operate as a waiver of any other breach of the same term thereafter. SCC shall not lose any right because it has not exercised it in the past.

Applicable Law. This Agreement is made in Michigan and shall be governed by and interpreted according to Michigan law. Any lawsuit arising out of this Agreement or the Goods may be handled by a federal or state court whose district includes Muskegon County, Michigan, and Purchaser consents that such court shall have personal jurisdiction over Purchaser.

Miscellaneous. If any provision of this Agreement is found to be invalid or unenforceable under any law, the provision shall be ineffective to that extent and for the duration of the illegality, but the remaining provisions shall be unaffected. Purchaser shall not assign any of its rights nor delegate any of this obligations under this Agreement without prior written of SCC. This Agreement shall be binding upon and inure to the benefit of SCC and Purchaser and each of their legal representatives, successors and assigns.

SCC warrants its products to be free of defects in materials and workmanship under normal use and service for a period of one (1) year from the date of delivery.

This warranty is extended only to the original purchaser for use of the Goods. It does not cover normal wear parts such as plastic tongs, tong holders, tong cables, bag holders, or acrylic dividers.

General Conditions. All service labor and/or parts charges are subject to approval by SCC. Contact the Customer Service Department in writing or call 231-798-8888.

All claims must contain the following information: (1) model & serial code number of equipment; (2) the date and place of installation; (3) the name and address of the agency which performed the installation; (4) the date of the equipment failure; and (5) a complete description of the equipment failure and all circumstances relating to that failure.

Once the claim has been determined to be a true warranty claim by SCC's Customer Service Department, the following procedure will be taken: (1) replacement parts will be sent at no charge from SCC on a freight prepaid basis; (2) reimbursement for service labor will be paid if the following conditions have been met— (a) prior approval of service agency was awarded from the Customer Service Department; and (b) an itemized statement of all labor charges incurred is received by the Customer Service Department. The cost of the service labor reimbursement will be based on straight time rates and reasonable time for the repair of the defect.

If problems occur with any compressor, notify SCC's Customer Service Department immediately. Any attempt to repair or alter the unit without prior consent from the Customer Service Department will render any warranty claim null and void. This warranty and protection plan does not apply to any condensing unit or any part thereof which has been subject to accident, negligence, misuse, or abuse, or which has not been operated in accordance with the manufacturer's recommendations or if the serial number of the unit has been altered, defaced, or removed.

Limit of Liability. The limit of liability of SCC toward the exchange cost of the original condensing unit, F.O.B. SCC, Norton Shores, MI, of each motor-compressor assembly replaced during the warranty shall not exceed manufacturer's current established wholesaler's exchange price and in no case shall the labor of removing or replacing the motor-compressor or parts thereof be the responsibility of SCC.