

FS Series - FSE End Cap Cases

Models

FSE45R

FSE65R



Applications

- Packaged products at end of counters, check-outs or grocery aisles
- Great for convenience stores & gas stations

Refrigerated self-service end cap

Standard Features

- Black interior
- Painted exterior
- Full end panel with mirror interior
- Open reach-in front
- Non-lighted sheet metal shelves
- T-8 top light
- Price tag molding
- Side electrical access
- Levelers
- Standard evaporator fans
- Double strip 1" bumper on front
- Remote refrigeration
- ETL Certified to CAN/CSA 22.2, conforms to UL 471 & NSF 7

Options

- White or stainless steel interior
- Laminate or stainless steel exterior
- White or gray trim at header
- Full end panel with cutaway glass
- Stainless steel lower panel
- Lighted sheet metal shelves
- Casters
- Breeze™ self contained refrigeration with 6' power cord
- Clean Sweep® coil cleaner
- Energy efficient evaporator fans

ONE PART PASSION, TWO PARTS SCIENCE



Specifications - FSE Cases

Model	LxDxH
FSE45R	36 5/8"x51 5/16"x61"
FSE65R	68 1/16"x34 3/16"x61"

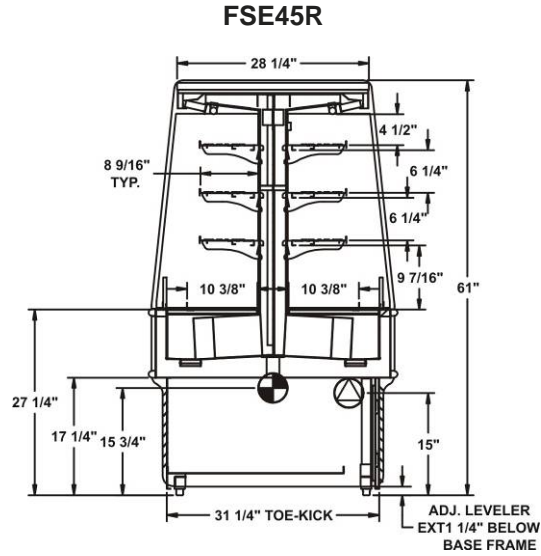
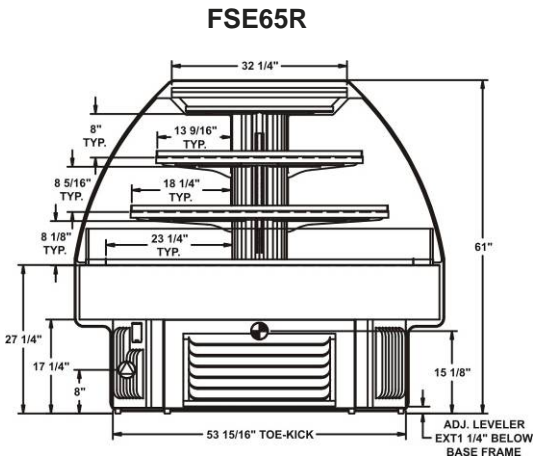

IMPORTANT NOTES

Compressor air side intake and side discharge.

INTENDED ENVIRONMENT

Designed to operate in ambient conditions of 75°F with 55% relative humidity.

Integrated average product temperature of 41°F.

INTENDED ENVIRONMENT

Packaged refrigerated products.

For more information on any of our products or services please visit us on the web at: www.structuralconcepts.com

INFORMATION IS SUBJECT TO CHANGE WITHOUT NOTICE.

