

# FS Series - FSIMT Multi-Temperature Island Cases



Self-service island merchandiser with temperature controlled display areas.

## Models CMIA

### Applications

- Four merchandising areas in one display—heated shelves, soup wells, back to back refrigerated grab & go
- Forced air refrigeration
- Medium temperature integrated average 41°F
- Heated end displays—160° F.

### Standard Features

- Black interior
- Painted exterior
- Refrigerated middle section: T-8 top light, two non-lighted solid shelves, removable deck pans to access evaporator coil
- Heated end section: two non-lighted heated shelves, individual heat controls for each level, stainless steel finish
- Soup end: two 7-qt stainless steel soup kettles, individual heat controls, shared on/off switch, storage area for supplies, suspended glass sneeze guard
- Glass top
- Electrical leads
- Standard evaporator fans
- Rails with shims
- Double strip 1" bumper all sides
- Remote refrigeration with TXV
- ETL certified to CAN/CSA 22.2, conforms to UL197, UL471, NSF 4 & NSF 7

### Options

- Stainless steel interior
- Stainless steel or laminated exterior
- Corian® soup display surface
- Lighted shelves in refrigerated section
- Breeze™ self-contained refrigeration with 6' power cord
- Clean Sweep® condenser coil cleaner
- Price tag molding
- Energy efficient evaporator fan

ONE PART PASSION, TWO PARTS SCIENCE



# Specifications - FSIMT Cases

Model	LxDxH
CMIA	87-9/16"x53-9/16"x63-7/16"

## STANDARD - Refrigerated View

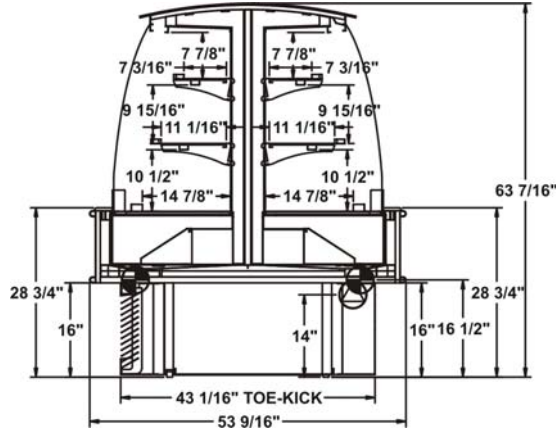

## Hot view

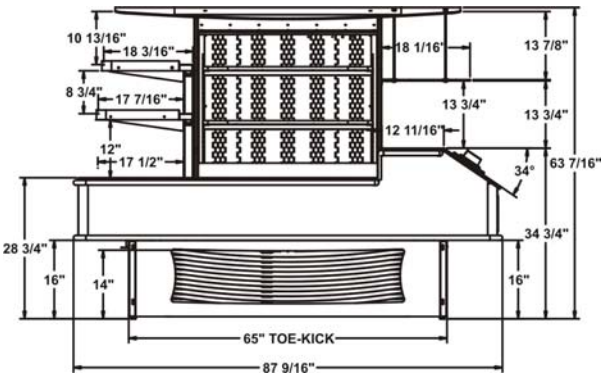

## Plan view

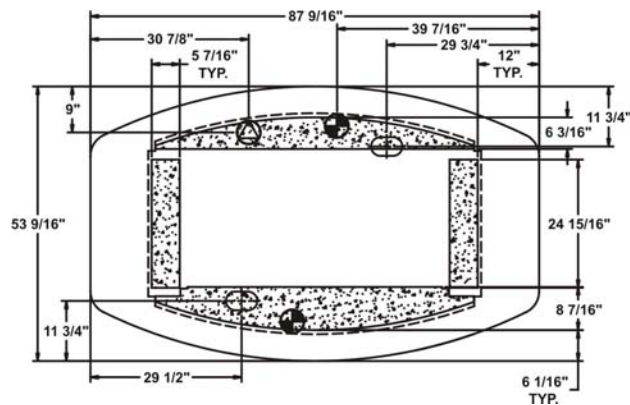

## IMPORTANT NOTES

Units are supplied with levelers which must be adjusted during installation to ensure the unit is level and plumb.

Dimensions reflect levelers extended 1-1/4".

## INTENDED ENVIRONMENT

Designed to operate in ambient conditions of 75°F with 55% relative humidity.

Refrigerated section: Integrated average product temperature of 41°F.

Heated section & Soup area: Integrated average product temperature of 160°F.

## INTENDED USE

Packaged refrigerated products.  
Packaged/unpackaged heated products.

For more information on any of our products or services please visit us on the web at:

[www.structuralconcepts.com](http://www.structuralconcepts.com)

INFORMATION IS SUBJECT TO CHANGE WITHOUT NOTICE.

