

FS Series - FSPS Refrigerated Prep Cases

Models

FSPS48
FSPS72



Refrigerated Preparation Cases

Applications

- Interactive preparation station
- Refrigerated condiment pans and storage allow product to be made for immediate consumption
- Medium temperature integrated average 41°F

Standard Features

- Curved single pane glass with lift assist cylinders
- Front glass in up position during operation; down to cover condiment pans
- Refrigerated wells for condiment pans
- Refrigerated rear storage
- Black trim
- Remote refrigeration with TXV
- Black toe kick
- Sanalite rear work ledge
- Laminated exterior
- ETL certified to CAN/CSA 22.2, conforms to UL 471 & NSF 7

Options

- Silver trim
- Stainless steel toe kick
- Richlite rear work ledge
- Choice of laminate colors
- Self-contained refrigeration with 6' power cord

ONE PART PASSION, TWO PARTS SCIENCE



Specifications - FSPS Cases

Model	LxDxH
FSPS48	48x39-3/4"x42-1/4"
FSPS72	72-1/8"x39-3/4"x42-1/4"

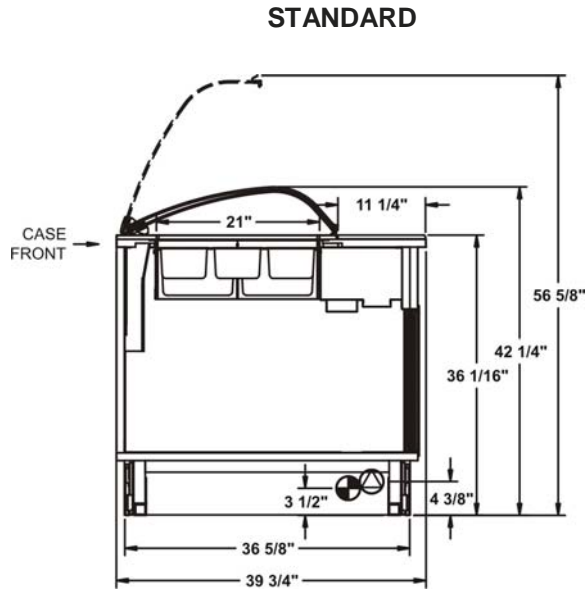

IMPORTANT NOTES

INTENDED ENVIRONMENT

Designed to operate in ambient conditions of 75° F. and 55% relative humidity.

Integrated average product temperature of 41° F.

INTENDED USE

Unpackaged refrigerated product

INFORMATION IS SUBJECT TO CHANGE WITHOUT NOTICE.



For more information on any of our products or services please visit us on the web at:

www.structuralconcepts.com