

FUSION INSTALLATION & OPERATING MANUAL

REFRIGERATED PREP CASE WITH REFRIGERATED REAR STORAGE

PN 63244



Model FSPS72

Model FSPS48



Model FSPS48
48" L x 39 7/8" D x 42 1/4" H*
Model FSPS60.4858
60" L x 39 7/8" D x 42 1/4" H*
Model FSPS72
72" L x 39 7/8" D x 42 1/4" H*
*36 1/16" To Top of Countertop
(Without Cover)



TABLE OF CONTENTS

TABLE OF CONTENTS	2
OVERVIEW AND WARNINGS	3
INSTALLATION: REMOVAL FROM SKID / ELECTRICAL CONNECTIONS (REMOTE CASES)	4
INSTALLATION: REFRIG. LINES / STUB-UPS / DRAIN / WIRING DIAGRAMS / START-UP	5
INSTALLATION: ELECTRICAL CONNECTIONS / MAIN POWER SWITCH (SELF-CONTAINED) ..	6
TXV VALVE ACCESS	7
MAINTENANCE FUNDAMENTALS - REAR SLIDING DOORS	8
CLEANING SCHEDULE - TO BE PERFORMED BY STORE PERSONNEL	9
CLEANING SCHEDULE - [RICHLITE® CUTTING BOARD]	10
TROUBLESHOOTING - GENERAL CASE ISSUES	11-12
TROUBLESHOOTING - CONDENSING SYSTEM (QUALIFIED SERVICE TECHNICIANS ONLY) ..	13
TROUBLESHOOTING - EVAPORATOR SYSTEM (QUALIFIED SERVICE TECHNICIANS ONLY) .	14
PREVENTIVE MAINTENANCE (TO BE PERFORMED BY TRAINED SERVICE PROVIDER)	15
CAREL TEMPERATURE CONTROLLER INFORMATION	16-18
SERIAL LABEL INFORMATION & LOCATION	19
TECHNICAL SERVICE CONTACT INFORMATION & WARRANTY INFORMATION	20

OVERVIEW AND WARNINGS

OVERVIEW

- These Structural Concepts cases are designed to merchandise packaged products at 41°F or less product temperatures.
- These cases should be installed and operated according to this operating manual's instructions to insure proper performance. Improper use will void warranty.

This unit is designed for the display of products in ambient store conditions where temperatures and humidity are maintained within a specific range.

- For NSF® Type 1 Conditions (most cases): ambient conditions are to be at 55% max. humidity / 75°F.
- For NSF® Type 2 Conditions: ambient conditions are to be at 60% maximum humidity / 80°F.
- If unsure if your case is Type 1 or Type 2, contact Structural Concepts Technical Service (see Technical Service section in this manual for phone number).

Caution: Do not allow air conditioning, electric fans, open doors or windows to create air currents around display case as this may detrimentally affect proper case temperatures and operation.



ATTENTION INSTALLER

This equipment must be installed in compliance with all applicable NEC, federal, state and local plumbing codes.



WARNING

Risk of electric shock.
Disconnect power before servicing unit



WARNING

More than one source of electrical supply may be employed with units that have separate circuits.
Disconnect all sources before servicing.



WARNING

Hazardous moving parts. Do not operate unit with covers removed.
Fan blades may be exposed when deck panel is removed.
Disconnect power before removing deck panel.



WARNING

Evaporator pan is Hot! Disconnect and allow to cool before cleaning or removing from case.

INSTALLATION: REMOVAL FROM SKID / ELECTRICAL CONNECTIONS (REMOTE CASES)

1. Remove Case (With Levelers or Frame Support Rails) From Skid

- To prevent damage, support case while sliding it toward edge of skid.
- When case is at edge of skid, carefully lower to floor so that two levelers (or one frame support tube) rests on floor.
- Carefully slide skid out from under case.
- After case is off skid, place into position.
- *Note: Illustration at right reflects general outline of sample case and does not reflect any particular model or options).*

- Voltage rating is on serial label at case rear.
- See next page for view of similar information on self-contained cases.

2. Remote Cases: Field Wiring Box, Probes Wiring Box and Receptacle Box are accessible at either front or rear.

- Front and/or rear toe-kick is removable by simply lifting up and off (no screws).
- Caution! Only certified electricians are to access electrical components!

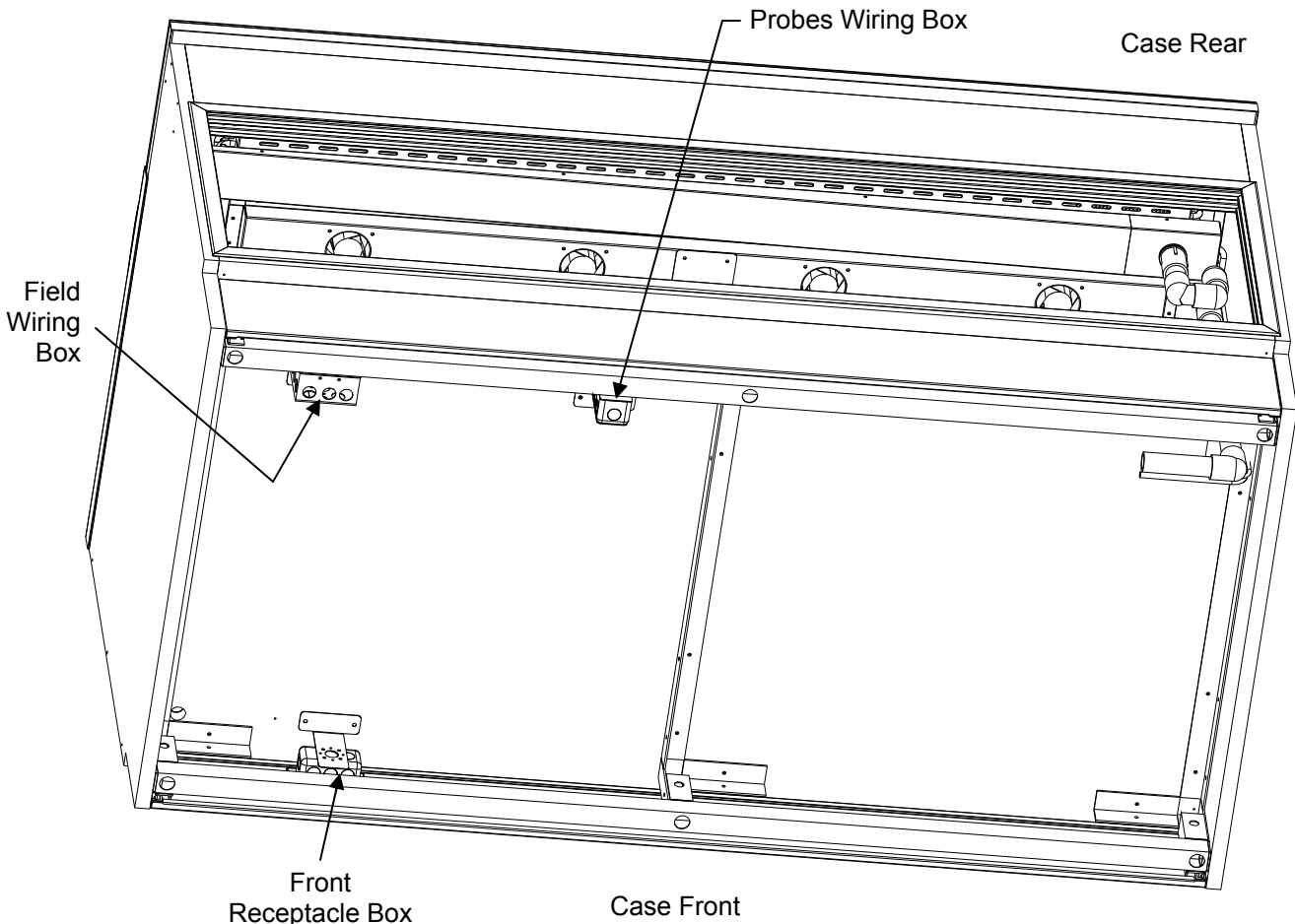
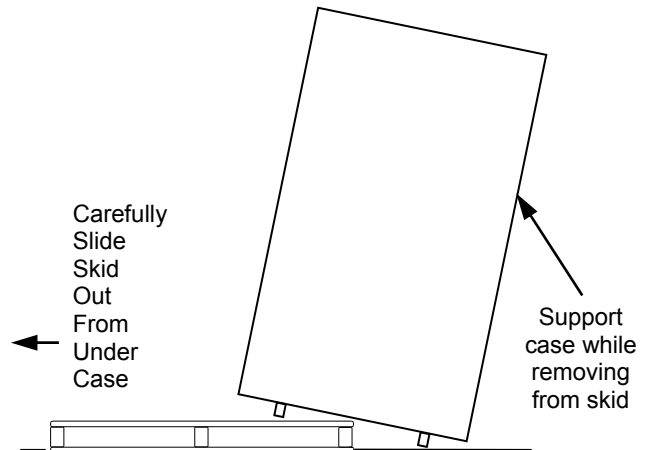

INSTALLATION: ELECTRICAL CONNECTIONS / MAIN POWER SWITCH (SELF-CONTAINED CASES)

Self-Contained Cases: Field Wiring Box, Probes Wiring Box and Receptacle Box are Accessible at Either Front or Rear

- Front and/or rear toe-kick is removable by simply lifting up and off (no screws).
- Caution! Only certified electricians are to access electrical components!
- Voltage rating is on serial label at case rear.
- See previous page for view of similar information on remote cases.

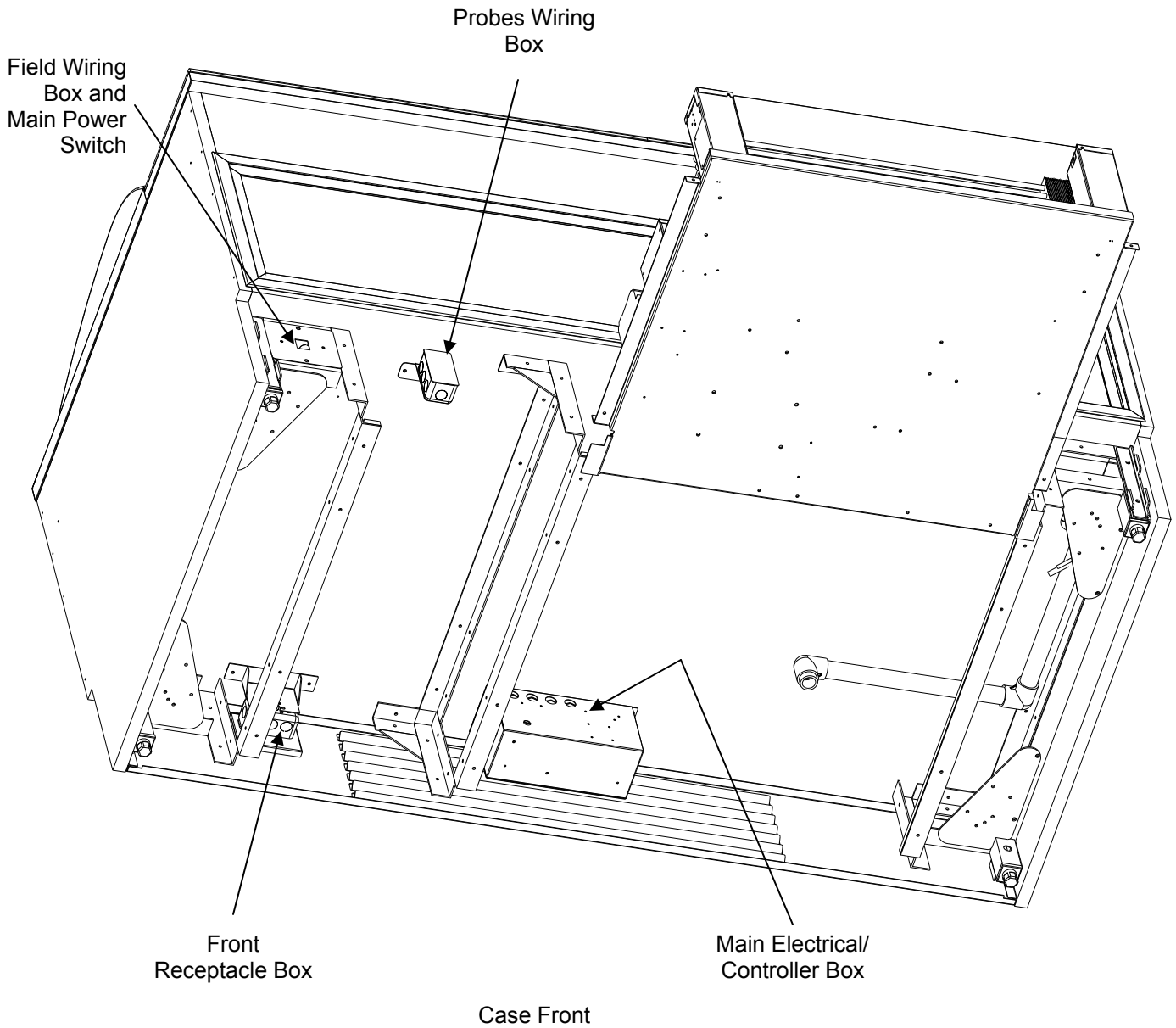

1. Refrigeration Line Stub-Up Connections

- Remove rear panel by simply lifting up and off (no screws). See illustration below.
- Stub-up connections are accessed at rear-right.

2. Refrigeration Drain Connection (Remote Units)

- Remove rear panel by simply lifting up and off (no screws). See illustration below.
- 1.5" male PVC stub-up connection is under the case at rear-right.
- Connect tub drain to floor drain. Maintain 1/4"-fall per foot to provide proper drainage.
- Illustration below may not reflect every feature or option of your particular case.

3. Electrical Wiring Diagram

- Each case has its own wiring diagram folded and in its own packet.
- Wiring diagram placement may vary; it may be placed near condenser fan cover, ballast box, raceway cover, or other related location.

4. Display Case Start-Up

- **Remote Cases:** Case will energize upon being properly field wired.
- **Self-Contained Cases:** Main power switch is located at rear of case, at lower left (see previous page for exact location).
- Lift glass cover and check that the coil fans are functioning properly (by detecting airflow through side airflow baffles).
- Evaporator fans should be on and airflow should be circulating.

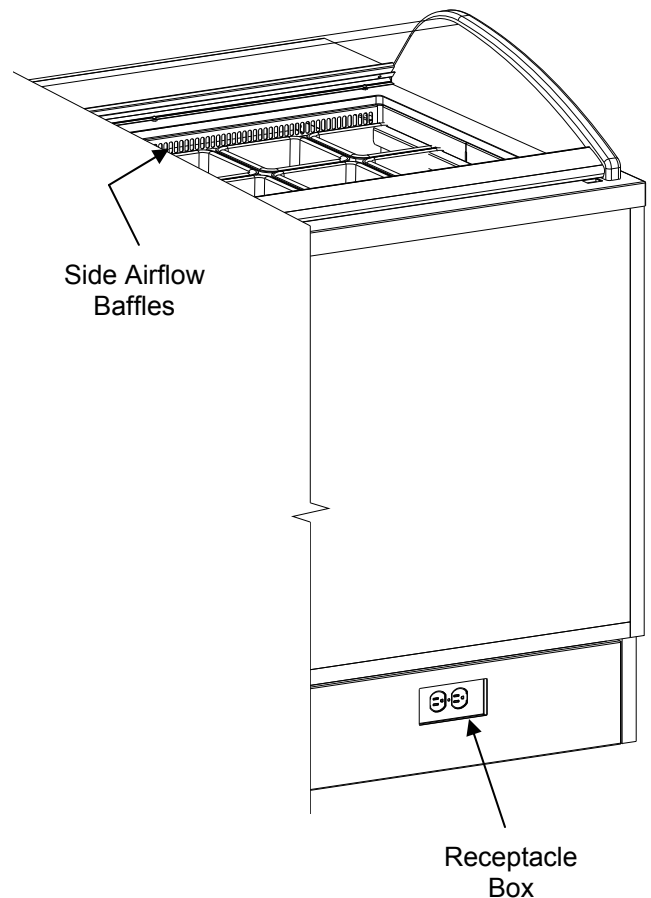
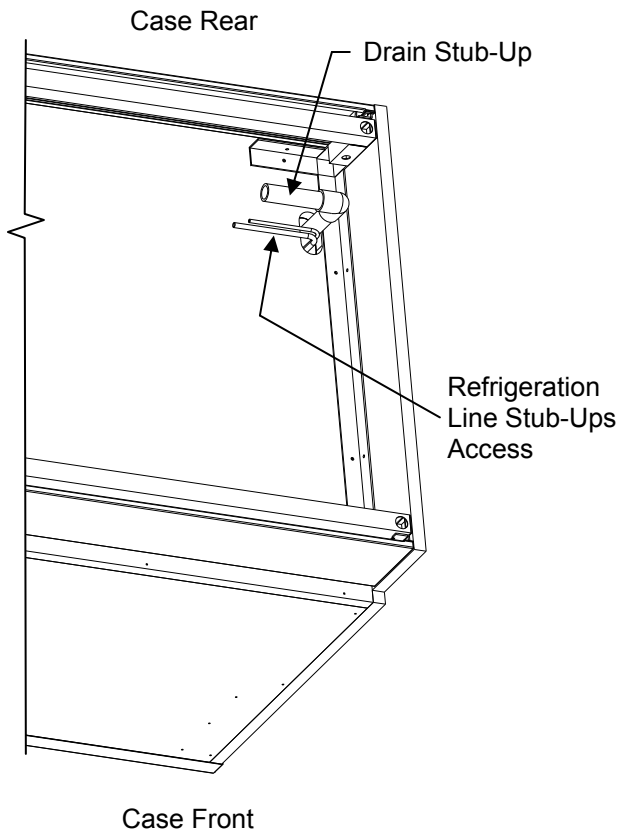

TXV VALVE ACCESS

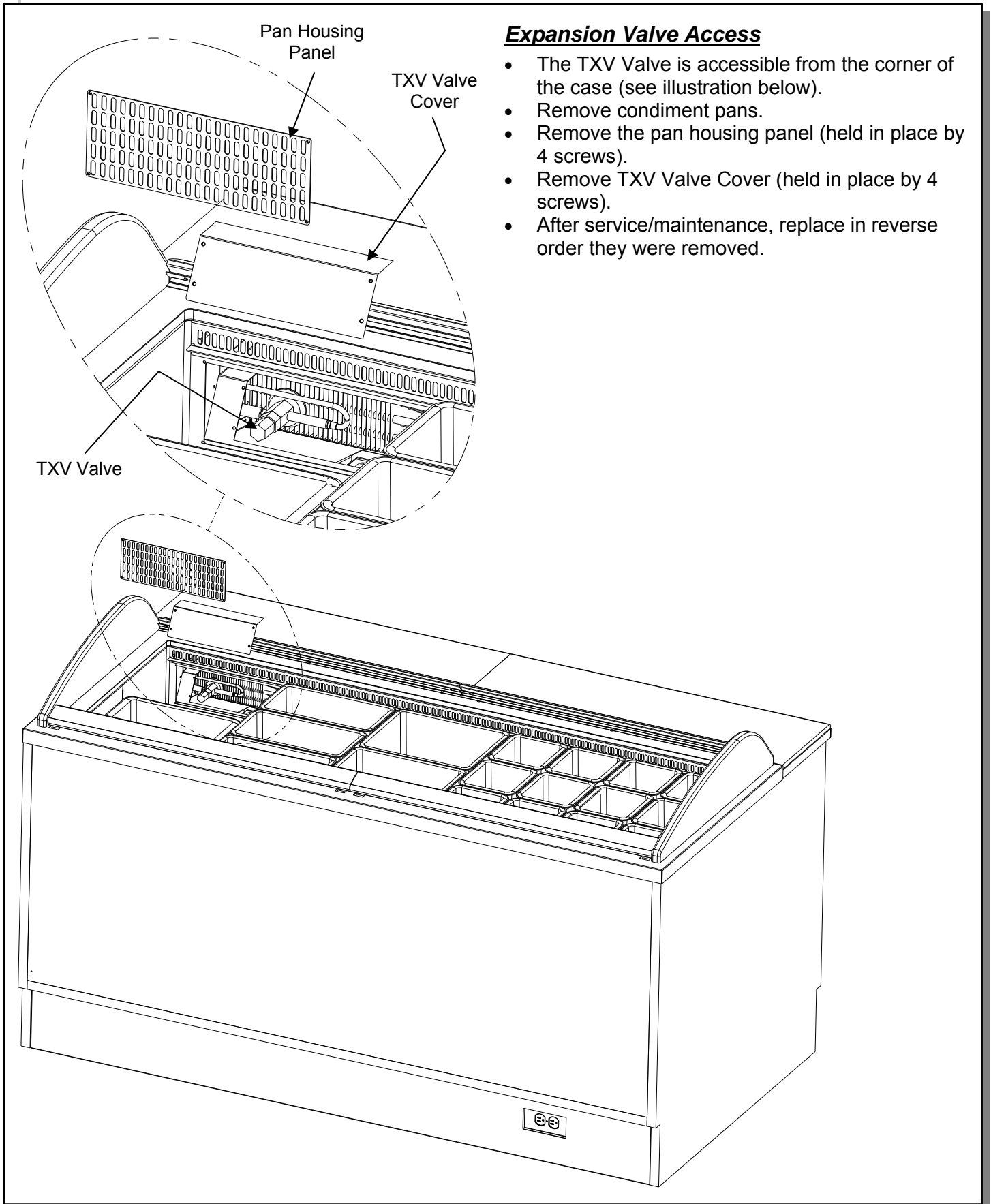

Expansion Valve Access

- The TXV Valve is accessible from the corner of the case (see illustration below).
- Remove condiment pans.
- Remove the pan housing panel (held in place by 4 screws).
- Remove TXV Valve Cover (held in place by 4 screws).
- After service/maintenance, replace in reverse order they were removed.

MAINTENANCE FUNDAMENTALS - REAR SLIDING DOORS

Removing the Rear Sliding Doors

Refrigeration Note: As rear storage area is refrigerated, be sure to keep sliding doors closed when not in use!

Non-Interchangeability: Doors are not interchangeable. There is an inner and outer door. The outer must be removed first and replaced last.

- The outer door is the left hand door (from the service side or rear of case).
- Move doors toward the center of the case.

- Individually lift each door up toward the top of the case; pivot the bottom of the door out.
- Carefully set rear sliding doors down to prevent them from falling.
- Removable/adjustable shelving exists in areas behind sliding doors. See illustration below.
- Replace in reverse order they were removed.
- Reverse to reinstall. See illustration below.
- **Caution:** Gently set doors down to avoid marring, scraping, scratching or breakage.

View of case with doors intact.

Doors are to be lifted up, pivoted out and away from case.

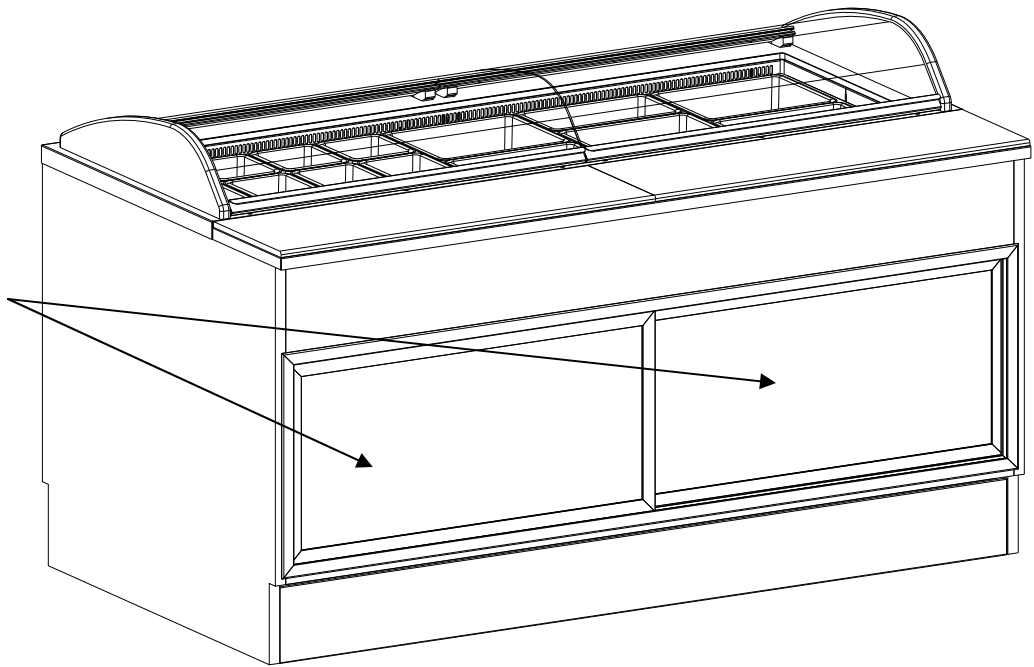

Removable/
Adjustable
Shelving

View of case with doors removed.
Note: Rear grille removed for illustrative purposes only.

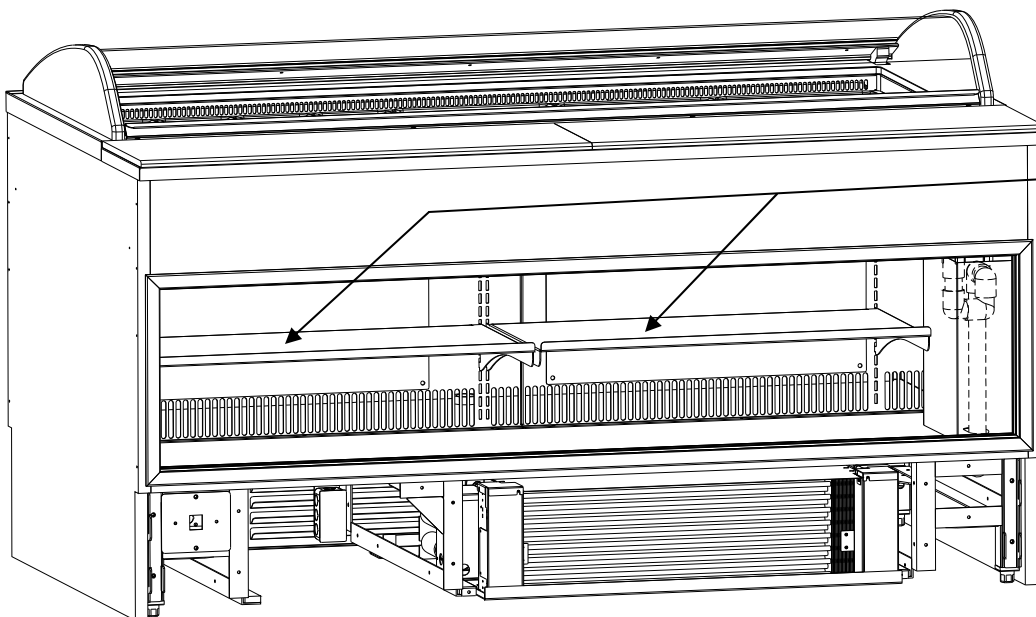

CLEANING SCHEDULE - TO BE PERFORMED BY STORE PERSONNEL

FREQ.	INSTRUCTIONS
Daily	<u>Pans and Pan Dividers:</u> Remove from case and submerge in warm water and mild soap solution. Dry with a non-abrasive cloth.
Daily	<u>Glass Pan Covers:</u> Clean glass pan covers with a household or commercial glass cleaner.
Daily	<u>Rear Sliding Door and Door Track:</u> Wipe off all surfaces with warm water and mild soap solution and non-abrasive cloth.
Daily	<u>End Panels, Front Panel, Toe-Kick, etc.:</u> Wipe off all surfaces with warm water and mild soap solution and non-abrasive cloth.
Daily	<u>Rear Cutting Board (Richlite®):</u> Wipe off surface with warm water and mild soap solution and non-abrasive cloth. See next page for Richlite® guidelines on routine care and upkeep, stain removal, scratch removal, and general precautions.
Daily	<u>Condenser Coil:</u> Remove rear panel. Clean condenser coil with dry brush to remove dust and debris. Return rear panel to case
Daily	<u>Magnetic Filter:</u> Magnetic filter at case rear (attached to rear panel). This filter prevents dust from entering refrigeration package's condenser coil. Remove from case. Submerge in water and mild detergent solution. Use soft-bristled brush to remove smoke and grease from filter. Rinse thoroughly and allow to dry.
Weekly	<u>Rear Storage Area:</u> Remove all items. Wipe down storage area with moist cloth dipped in mild soap and water solution.
Weekly	<u>Pan Reservoir (Main Tub):</u> Remove all pans and pan dividers. Wipe down with moist cloth dipped in mild soap and water solution.
Weekly	<u>Rear Cutting Board (Richlite®):</u> Lift up and off rear surface. Submerge in warm water and mild soap solution. Clean thoroughly. Dry with a clean, non-abrasive cloth. See next page for Richlite® guidelines on routine care and upkeep, stain removal, scratch removal, and general precautions. Note: Clean rear work area (where the cutting board sits) before returning Richlite® cutting board to display case.
Monthly	<u>Under Case Cleaning:</u> Remove front and/or rear toe-kick. Vacuum (or broom) under case to remove all dust and dirt. Replace front and/or rear toe-kick when complete.



Care & Maintenance

Routine Cleaning and Upkeep

Richlite® surface is a durable, attractive material designed to stay beautiful for the lifetime of your kitchen, bath or office space. A simple wipe up with soap and warm water on a regular basis will maintain its beauty.

Richlite's testing laboratory recommends that fabricators finish the surface with a non-oil-based sealant to provide a rich, polished finish that requires minimum care.

Removing Stains

Generally speaking, Richlite® resists stains quite well. As with most any material, there is a potential for some staining. With stubborn stains, try a non-abrasive household cleaner – Richlite® highly recommends SimpleGreen®* All-Purpose Cleaner because of its effectiveness and earth friendly ingredients.

Repairing Scratches & Burn Marks

Richlite® is extremely dense and durable. The material is resistant to scratches and burns but, like most surfaces, can potentially be damaged by cutting directly on the surface or setting a red-hot frying pan on the surface. Richlite recommends the use of cutting boards, hot pads and trivets to protect the surface from potential damage.

Before you decide to refinish your counter, please contact your dealer or fabricator who installed the counter for advice. In most cases, it is preferable if the installer refinishes the surface for you. Light scratch marks and burn marks can be refinished using a Scotch-Brite®* pad (#7447/ Red Color). It is important to note, the refinished area will noticeably lighten compared to the surrounding surface area. Richlite® is made of paper which, like wood, patinas – or darkens – over time, especially in the lighter colors. The area will eventually patina and match the remainder of the counter surrounding it. [Click here for more information on Patina.](#) In order to avoid affecting one spot, lightly refinish the entire section of the counter.

General Precautions

Your countertop is stain resistant to most all kitchen related substances with the exception of some raw meat juice (such as liver), high-alkaline fruit or vegetables (such as papaya and red beet), and high-alkaline soaps (such as automatic dishwasher powder) when left in contact for a prolonged time. Additionally grout (which is a high alkaline product) will lighten darker-colored Richlite® counters and darken the lighter tones. Cover the surface with a protective sheet when you are installing tile around countertop area.

* SimpleGreen is a registered trademark of Sunshine Makers, Inc.; and Scotch-Brite is a registered trademark of 3M Company.

CONDITION	TROUBLESHOOTING
Case Not Level	See FRAME SUPPORT RAILS section in this manual for information on shims (to leveling case).
Water Is On The Floor	<p>Caution! Water on flooring can cause much damage! Until cause is determined (and repaired), following these procedures:</p> <ul style="list-style-type: none"> • Use wet-dry vacuum (or mop & bucket) to remove standing water. • Use 'catch pans' for water to drain into. Swap out regularly until case has completely drained.
	Check that the drain trap is free of debris.
	Check that the drain hose is correctly positioned over floor drain (or, in self-contained units, the evaporator pan).
	Check store conditions. To prevent condensation in NSF® Type 1 environments, maximum conditions are to be 55% humidity / 75° Fahrenheit. For NSF® Type 2, maximum conditions are to be 60% humidity / 80° Fahrenheit. See serial label (at case rear near main power switch) for NSF® Type of your case.
	Check evaporator pan float for proper operation (Heat Rod Evaporator System only).
	For cases with evaporator pan, check that it is plugged in.
	<p>Caution! Evaporator pan may be malfunctioning (Electrical Heat Rod Evaporator system). If so, water will overflow pan and seep onto flooring causing damage! Until evaporator pan is functioning (or is replaced), following these procedures:</p> <ul style="list-style-type: none"> • Use wet-dry vacuum (or mop & bucket) to remove standing water. • Use 'catch pans' for water to drain into. Swap out regularly until case has completely drained.
	<p>Caution! Disruption of power can cause water to overflow pan and seep onto flooring causing damage! Check that power to case is constant. Until power is restored, following these procedures:</p> <ul style="list-style-type: none"> • Use wet-dry vacuum (or mop & bucket) to remove standing water. • Use 'catch pans' for water to drainage. Swap out regularly until evaporation of case is complete (or until power is restored). • When power to case is restored, evaporator pan should function properly and water will no longer overflow onto flooring.
	<p>Wicking material may be dirty or worn and need replacement (hot gas evaporator system).</p> <ul style="list-style-type: none"> • Slide refrigeration system out from under unit. • After refrigeration system has been carefully slid out from under unit, replace wicking material with new. If wicking material is not available, contact Structural Concepts®. See toll-free number at last page of this operating manual.
	If unable to resolve water drainage issues, contact Structural Concepts Technical Service (see telephone number and website at last page of this operating manual).

CONDITION	TROUBLESHOOTING
Fan Emits Excessive Noise	Check that the case is aligned, level and plumb.
	Check evaporator fans for cleanliness.
	Check that fan motors are securely mounted in brackets.
	Check that nothing is preventing blade rotation.
	Check that the fan shroud is properly secured.
Fans Are Not Working	Check that the MAIN power switch (if present) is on.
	Check for foreign material obstructing fan performance.
	Check that fan blades freely rotate within fan shrouds.
	Check that power is going to fans.
	Check that fan wiring is connected on terminal blocks.
System Is Not Operating	Check that the utility power is on.
	Check the store's circuit breaker box for tripped circuits.
Case Is Not Holding Temperature	If a large amount of warm product was added to the case, it will take time for the temperature to adjust. Product should be pre-chilled before placing in the display case.
	Check Temperature Controller section in this manual.
	Check that the case is not in the sun or near a heat or air conditioning vent.
	If case is located near outside doors, temperature fluctuation can hinder unit's ability to maintain temperature.
	Check that product is not obstructing air flow. If product is 'piled too high', air flow can be obstructed, preventing proper temperatures.
	Maintain airflow clearance of at least 6" at rear of case.
	Check sight glass for flashing and/or low charge.
	Check Set Point Temperature; it may be adjusted too high.

TROUBLESHOOTING - CONDENSING SYSTEM (QUALIFIED SERVICE TECHNICIANS ONLY)

CONDITION	TROUBLESHOOTING
Head Pressure Too High	Check that the Condensing Coil is not dirty or covered.
	Check that Condensing Fans are working.
	Check that the refrigeration system is not overcharged.
	Check that case is free of non-condensables.
	Check that Liquid Line Drier Filter is not plugged.
	Check Set Point temperature; it may be adjusted too high.
	Check System Operating temperatures.
	Check that Store Ambient temperature isn't above maximum allowed. See <i>Overview and Warnings</i> Section.
Head Pressure Too Low	Check that Refrigerant Charge isn't too low.
	Check that Suction Pressure isn't too low.
	Check to verify that Compressor Valves aren't faulty.

TROUBLESHOOTING - EVAPORATOR SYSTEM (QUALIFIED SERVICE TECHNICIANS ONLY)

CONDITION	TROUBLESHOOTING
Control Display Is Flashing	Check Temperature Controller section in this manual.
Condensing Unit Is Not Operating (Self-Contained Units Only)	Check Temperature Controller section in this manual.
	Check that the power is turned on.
	Review Temperature Controller's Settings for accuracy.
Low Suction Pressure	Check for low refrigerant.
	Check that Expansion Valve isn't restricted.
	Check that Liquid Line or Filter isn't restricted.
	Check that Evaporator Motors are working.
	Check for Superheat setting.
	Check that the Thermostatic Element charge isn't depleted.
	Check that the Coil is not iced up.
High Suction Pressure	Check that Refrigerant Charge isn't too high.
	Check that Compressor Valves aren't faulty.
	Check that there is no air seepage around Condensing Coil.
	Check that the Cooling Load isn't high.
	Check that Superheat adjustment isn't low.
	Check TXV Bulb Installation a. Poor thermal contact. b. Warm location.
	Check Compressor: Low capacity means it is undersized for its application.

PREVENTIVE MAINTENANCE (TO BE PERFORMED BY TRAINED SERVICE PROVIDER)

WARNING! TURN OFF CASE BEFORE PERFORMING PREVENTIVE MAINTENANCE!

PREVENTIVE MAINTENANCE	FREQUENCY	INSTRUCTIONS
Case Exterior	Monthly	<p><u>Condensing Coil:</u></p> <ul style="list-style-type: none"> • Remove Rear Grille (by simply lifting up and off). No screw removal required. • Use air pressure or industrial strength vacuum; clean dust and dirt that may collect on the Condenser Coil. • <i>Caution! Coil fins are sharp. Handle with care!</i> • Replace Rear Grille to case (4 screws).
	Monthly	<p><u>Evaporator Pan:</u> <i>Caution! Disconnect from receptacle box.</i></p> <ul style="list-style-type: none"> • Remove mounting screws from base. • Use de-scaling solution (such as CLR® that will prevent corrosion, lime and rust) to clean pan. • Rinse thoroughly; do not submerge in water. • Reattach pan to case with same mounting screws. • Reconnect power cord to receptacle box.
	Quarterly	<p><u>Compressor Area:</u> <i>Caution! Be certain to disconnect power from case before cleaning Compressor Area!</i></p> <ul style="list-style-type: none"> • Slide/Roll compressor package out from under case. • Use moist cloth to wipe off dust & debris that collects on various parts. • Slide/Roll compressor package back under case.
	Quarterly	<p><u>Under Case Cleaning:</u> Once refrigeration package is clear of unit, vacuum under case to remove all dust and dirt that may collect under case.</p>
Case Interior	Quarterly	<p><u>Tub, Coil, Drain, Fan Blades, Motors, Brackets:</u> <i>Disconnect power from the case before cleaning the Tub, Coil, Fan, Motor and Drain Area!</i></p> <ul style="list-style-type: none"> • Remove Pans, Decking, Sub-Deck and Fan Shroud. • Use vacuum to clean Evaporator Coils. • Clean Tub, Coil and Drain with warm water, clean cloth, brush and mild soap solution. • Remove any debris that may clog drain. • Remove Fan Brackets. Clean Blades by wiping down with moist cloth.

CAREL

ir33 platform
 Integrated Electronic
 Microprocessor Controller



Programming The Instrument

To Modify The Setpoint

Set Press and hold the "SET" key for at least 1 second.

▲/aux **def/▼** 2. Use arrow keys ▲ ▼ on temperature controller to increase (or decrease) the setpoint.

Set 3. Quickly press and release the "SET" key again.

To Modify Defrost, Differential or Other Parameters

Prg/mute **Set** 1. Press & hold "Prg" & "SET" keys together for five (5) seconds; display will flash "0", representing password prompt.

Set 2. Confirm by pressing "SET" key.

▲/aux **def/▼** 3. Press ▲ or ▼ to reach the category to be modified.

Set 4. Press "SET" to modify this selected parameter.

▲/aux **def/▼** 5. Increase or decrease the value using the ▲ or ▼ button respectively.

Set 6. Press the "SET" key to temporarily save the new value and return to the display of the parameter.

Prg/mute 7. Press & hold the "Prg" key for at least 5 seconds to save changes. This action will also mute the audible alarm (buzzer) & deactivate the alarm relay.

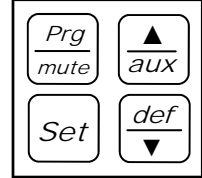

How To Change Reading From Fahrenheit (°F) To Celsius (°C)

Prg/mute **Set** 1. Press and hold "Prg" and "SET" keys together for at least 5 seconds; display will show "0", representing password prompt.

Set 2. Confirm by pressing "SET" key.

▲/aux **def/▼** 3. Press ▲ or ▼ until reaching the parameter "15".

Set 4. Press "SET" to modify this selected parameter.

▲/aux **def/▼** 5. Press ▲ or ▼ to change value to desired setting: "0" for Celsius (°C) or "1" for Fahrenheit (°F).

Set 6. Press "SET" key to temporarily save the new value and return to the display of the parameter.

Prg/mute 7. Press & hold "Prg" key for at least 5 seconds to save changes. **Note! All values will automatically convert to new scale. No conversion is required.**

Warning! Save Your Parameter Settings!

1. To store the new parameter values, PRESS and HOLD the "Prg" key for at least 5 seconds.
2. All modifications made to parameters will be lost if you do NOT press a button within 60 seconds. Should this "timeout" occur, normal operational settings (prior to modifications being made) will resume.
3. If the instrument is switched off before pressing the "Prg" key, all modifications to parameters will be lost.

def/▼ **To Activate Manual Defrost**
 Press and hold the "def" key for at least 5 seconds.

▲/aux **To Activate / Deactivate Auxiliary Output**
 Press and hold the "aux" key for 1 second.

Prg/mute **▲/aux** **To Reset Any Alarms With Manual Reset**
 Press and hold the "Prg" and "aux" key for at least 1 second.

CAREL

ir33 platform
**Integrated Electronic
 Microprocessor Controller**



User Interface - Display

ICON	FUNCTION	DESCRIPTION	ON	Normal operation OFF	BLINK	Start up
	COMPRESSOR	ON when the compressor starts. Flashes when the activation of the compressor is delayed by safety times.	Compressor on	Compressor off	awaiting activation	
	FAN	ON when the fan starts. Flashes when the activation of the fan is prevented due to external disabling or procedures in progress.	Fan on	Fan off	awaiting activation	
	DEFROST	ON when the defrost is activated. Flashes when the activation of the defrost is prevented due to external disabling or procedures in progress.	Defrost in progress	Defrost not in progress	awaiting activation	
	AUX	Flashes if the anti-sweat heater function is active, ON when the auxiliary output (1 and/or 2) selected as AUX (or LIGHT in firmware version 3.6) is activated.	AUX auxiliary output active (version 3.6 light auxiliary output active)	AUX auxiliary output not active	Anti-sweat heater function active	
	ALARM	ON following pre-activation of the delayed external digital input alarm. Flashes in the event of alarms during normal operation (e.g. high/low temperature) or in the event of alarms from an immediate or delayed external digital input.	Delayed external alarm (before the time 'A7' elapses)	No alarm present	Alarms in norm. operation (e.g. High/low temperature) or immediate or delayed alarm from external digital input	
	CLOCK	ON if at least one timed defrost has been set. At start-up, comes ON for a few seconds to indicate that the Real Time Clock is fitted.	If at least 1 timed defrost event has been set	No timed defrost event set	Alarm clock	ON if real-time clock present
	LIGHT	Flashes if the anti-sweat heater function is active, ON when the auxiliary output (1 and/or 2) selected as LIGHT is activated (in firmware version 3.6 it does not flash in anti-sweat heater mode and comes on when the dead band output is active).	Light auxiliary output on (version 3.6 dead band auxiliary output active)	Light auxiliary output off	Anti-sweat heater function active (version 3.6 does not flash in anti-sweat heater mode)	
	SERVICE	Flashes in the event of malfunctions, for example E2PROM errors or probe faults.		No malfunction	Malfunction (e.g. E2PROM error or probe fault). Contact service	
	CONTINUOUS CYCLE	ON when the CONTINUOUS CYCLE function is activated. Flashes if the activation of the function is prevented due to external disabling or procedures in progress (E.g.: minimum compressor OFF time).	CONTINUOUS CYCLE operation activated	CONTINUOUS CYCLE function not activated	CONTINUOUS CYCLE operation requested	

Summary Table of Alarm and Signals: Display, Buzzer and Relay

Code	Icon on the display	Alarm relay	Buzzer	Reset	Description
rE	flashing	on	on	automatic	virtual control probe fault
E0	flashing	off	off	automatic	room probe S1 fault
E1	flashing	off	off	automatic	defrost probe S2 fault
E2	flashing	off	off	automatic	probe S3 fault
E3	flashing	off	off	automatic	probe S4 fault
E4	flashing	off	off	automatic	probe S5 fault
'	No	off	off	automatic	probe not enabled
LO	flashing	on	on	automatic	low temperature alarm
HI	flashing	on	on	automatic	high temperature alarm
AFr	flashing	on	on	manual	antifreeze alarm
IA	flashing	on	on	automatic	immediate alarm from external contact
dA	flashing	on	on	automatic	delayed alarm from external contact
dEF	on	off	off	automatic	defrost running
Ed1	No	off	off	automatic/manual	defrost on evaporator 1 ended by timeout
Ed2	No	off	off	automatic/manual	defrost on evaporator 2 ended by timeout
Pd	flashing	on	on	automatic/manual	maximum pump down time alarm
LP	flashing	on	on	automatic/manual	low pressure alarm
AtS	flashing	on	on	automatic/manual	autostart in pump down
cht	No	off	off	automatic/manual	high condenser temperature pre-alarm
CHT	flashing	on	on	manual	high condenser temperature alarm
dor	flashing	on	on	automatic	door open too long alarm
EE	flashing	off	off	automatic	E2prom error, unit parameters
EF	flashing	off	off	automatic	E2prom error, operating parameters
ccb	Signal				start continuous cycle request
ccE	Signal				end continuous cycle request
dFb	Signal				start defrost call
dFE	Signal				end defrost call
On	Signal				switch ON
off	Signal				switch OFF
rES	Signal				reset alarms w/manual reset / reset HACCP alarms / reset temp. monitoring

CAREL

ir33 platform
 Integrated Electronic
 Microprocessor Controller



Summary Table of Operating Parameters

CODE	PARAMETER	UOM*	TYPE	MINIMUM	MAXIMUM	DEFAULT
/5	Select Celcius (°C) or Fahrenheit (°F)	flag	C	0	1	For Case Specific Defaults See Serial Label Located Near Electrical Access On Your Case. For Additional Technical Information Call Structural Concepts Technical Service Dept. at 1(800) 433.9489
/c1	Calibration of probe 1	°C/°F	C	-20	20	
/c2	Calibration of probe 2	°C/°F	C	-20	20	
St	Temperature set point	°C/°F	F	r2	r1	
rd	Control delta	°C/°F	F	20	0.1	
dl	Interval between defrosts	hours	F	0	250	
dt1	End defrost temperature, evaporator	°C/°F	F	-50	200	
dP1	Maximum defrost duration, evaporator	min	F	1	250	
d6	Display on hold during defrost	-	C	0	2	
dd	Dripping time after defrost	min	F	0	15	
d/1	Display of defrost probe 1	°C/°F	F	-	-	

* Unit Of Measure

Serial Label Location & Information Listed / Technical Information & Service

- Serial labels are located near the electrical access on your case.
- Serial labels contain electrical, temperature & refrigeration information, as well as regulatory standards to which the case conforms.
- For additional technical information and service, see the *TECHNICAL SERVICE* page in this manual for instructions on contacting Structural Concepts' Technical Service Department.
- See images below for samples of both refrigerated and non-refrigerated serial labels.



888 E. Porter Rd · Muskegon, MI 49441

ENCORE[®] MODEL HV74RSS SCROLL
SERIES SERIAL NO.

FOR PARTS AND SERVICE
CALL 1-800-433-9489



3048256
CONFORMS TO UL STD 471
CONFORMS TO NSF STD 7
CERTIFIED TO CAN/CSA
STD C22.2 NO 120

ELECTRICAL RATING 120/1/60 24A
REFRIGERANT R404A AMOUNT ?? OZ
DESIGN PRESSURE HIGH 450 LOW 200
MINIMUM CIRCUIT 30A
MAXIMUM OVERCURRENT 30A

SAMPLE ONLY

Super Heat Temp 8-10°F
BTUH Requirements 9,738 BTUH @ 20° F SST
Defrost 6 defrosts per day, 45° F termination, 45 min. failsafe

SAMPLE ONLY

----- Sample Serial Label For Refrigerated Case -----



888 E. Porter Rd · Muskegon, MI 49441

Addenda[®] PC5682 txtRemote
txtSerialNumber

120 VOLTS 60 HZ SINGLE PHASE 1.84AMP

FOR PARTS OR SERVICE CALL
STRUCTURAL CONCEPTS
AT
1-800-433-9489



3048256
CONFORMS TO UL STD 65
CERTIFIED TO CAN/CSA
STD C22.2 NO 120

SAMPLE ONLY

----- Sample Serial Label For Non-Refrigerated Case -----

STRUCTURAL CONCEPTS CORPORATION TECHNICAL SERVICE
PHONE NUMBER: 1.800.433.9489 or For Your Master Service Agent See
WWW.STRUCTURALCONCEPTS.COM/Contact/Master_Service_Agents.asp

WARRANTY INFORMATION

(Note: Standard Limited Warranty can be found at www.Structuralconcepts.com)

All sales by Structural Concepts Corporation (SCC) are subject to the following limited warranty. "Goods" refers to the product or products being sold by SCC.

Warranty Scope: Warranty is for equipment sold in the United States, Canada, Mexico and Puerto Rico. Limited warranty may apply to equipment sold elsewhere.

Warranty; Remedies; Limitations. SCC warrants that if any Goods are found by an authorized representative of SCC not to be of good material or workmanship within one year of the date of shipments SCC will, at its option after inspection by an authorized representative, replace any defective Good or pay the reasonable cost of replacement for any such defective Goods, provided that written notice of the defect is given to SCC within 30 days of the appearance of such defect. If notice is not given within such period, any claim for breach of warranty shall be conclusively deemed to have been waived and SCC shall not be liable under this warranty. If SCC is unable to repair or replace the defective Goods, SCC shall issue a credit to the Purchaser for all or part of the purchase price, as SCC shall determine. The replacement or payment in the manner described above shall be the sole and exclusive remedy of Purchaser for a breach of this warranty. If any Goods are defective or fail to conform to this warranty, SCC will furnish instructions for their disposition. No Goods shall be returned to SCC without its prior consent.

SCC's liability for any defect in the Goods shall not exceed the purchase price of the Goods. SCC SHALL HAVE NO LIABILITY TO PURCHASE FOR CONSEQUENTIAL DAMAGES OF ANY KIND WHATSOEVER, INCLUDING, BUT NOT LIMITED TO, PERSONAL INJURY, PROPERTY DAMAGE, LOST PROFITS, OR OTHER ECONOMIC INJURY DUE TO ANY DEFECT IN THE GOODS OR ANY BREACH OF SCC. SCC SHALL NOT BE LIABLE TO THE PURCHASER IN TORT FOR ANY NEGLIGENT DESIGN OR MANUFACTURE OF THE GOODS, OR FOR THE OMISSION OF ANY WARNING THEREFROM.

SCC shall have no obligation or liability under this warranty for claims arising from any other party's (including Purchaser's) negligence or misuse of the Goods or environmental conditions. This warranty does not apply to any claim or damage arising for or cause by improper storage, handling, installation, maintenance, or from fire, flood, accidents, structural defects, building settlement or movement, acts of God, or other causes beyond SCC's control.

Except as expressly stated herein, SCC makes no warranty, express, implied, statutory or otherwise as to any parts or goods not manufactured by SCC. SCC shall warrant such parts or Goods only (I) against such defects, (II) for such periods of time, and (III) with such remedies, as are expressly warranted by the manufacturer of such parts of Goods. Notwithstanding the foregoing, any warranty with respect to such parts of Goods and any remedies available as a result of a breach thereof shall be subject to all of the procedures, limitations, and exclusions set forth herein.

THE WARRANTIES HEREIN ARE IN LIEU OF ALL WARRANTIES, EXPRESS, IMPLIED, STATUTORY, OR OTHERWISE. IN PARTICULAR, SCC MAKES NO WARRANTY OF MERCHANTABILITY OR FITNESS FOR A PARTICULAR PURPOSE.

No representative, agent or dealer of SCC has authority to modify, expand, or extend this Warranty, to waive any of the limitations or exclusions, or to make any different or additional warranties with respect to Goods.

Period of Limitations. No claim, suit or other proceeding may be brought by Purchaser for any breach of the foregoing warranty or this Agreement by SCC or in any way arising out of this Agreement or relating to the Goods after one year from the date of the breach. In the interpretation of this limitation on action for a breach by SCC, it is expressly agreed that there are no warranties of future performance of the goods that would extend that period of limitation herein contained for bringing an action.

Indemnifications. Purchaser agrees to indemnify, hold harmless, and defend SCC if so requested, from any and all liabilities, as defined herein, suffered, or incurred by SCC as a result of, or in connection with, any act, omission, or use of the Goods by Purchaser, its employees or customers, or any breach of this Agreement by Purchaser. Liabilities shall include all costs, claims, damages, judgments, and expenses (including reasonable attorney fees and costs).

Remedies of SCC. SCC's rights and remedies shall be cumulative and may be exercised from time to time. In a proceeding or action relating to the breach of this Agreement by Purchaser, Purchaser shall reimburse SCC for reasonable costs and attorney's fees incurred by SCC. No waiver by SCC of any breach of Purchaser shall be effective unless in writing nor operate as a waiver of any other breach of the same term thereafter. SCC shall not lose any right because it has not exercised it in the past.

Applicable Law. This Agreement is made in Michigan and shall be governed by and interpreted according to Michigan law. Any lawsuit arising out of this Agreement or the Goods may be handled by a federal or state court whose district includes Muskegon County, Michigan, and Purchaser consents that such court shall have personal jurisdiction over Purchaser.

Miscellaneous. If any provision of this Agreement is found to be invalid or unenforceable under any law, the provision shall be ineffective to that extent and for the duration of the illegality, but the remaining provisions shall be unaffected. Purchaser shall not assign any of its rights nor delegate any of its obligations under this Agreement without prior written of SCC. This Agreement shall be binding upon and inure to the benefit of SCC and Purchaser and each of their legal representatives, successors and assigns.

SCC warrants its products to be free of defects in materials and workmanship under normal use and service for a period of one (1) year from the date of delivery.

This warranty is extended only to the original purchaser for use of the Goods. It does not cover normal wear parts such as plastic tongs, tong holders, tong cables, bag holders, or acrylic dividers.

General Conditions. All service labor and/or parts charges are subject to approval by SCC. Contact the Customer Service Department in writing or call 231-798-8888.

All claims must contain the following information: (1) model & serial code number of equipment; (2) the date and place of installation; (3) the name and address of the agency which performed the installation; (4) the date of the equipment failure; and (5) a complete description of the equipment failure and all circumstances relating to that failure.

Once the claim has been determined to be a true warranty claim by SCC's Customer Service Department, the following procedure will be taken: (1) replacement parts will be sent at no charge from SCC on a freight prepaid basis; (2) reimbursement for service labor will be paid if the following conditions have been met— (a) prior approval of service agency was awarded from the Customer Service Department; and (b) an itemized statement of all labor charges incurred is received by the Customer Service Department. The cost of the service labor reimbursement will be based on straight time rates and reasonable time for the repair of the defect.

If problems occur with any compressor, notify SCC's Customer Service Department immediately. Any attempt to repair or alter the unit without prior consent from the Customer Service Department will render any warranty claim null and void. This warranty and protection plan does not apply to any condensing unit or any part thereof which has been subject to accident, negligence, misuse, or abuse, or which has not been operated in accordance with the manufacturer's recommendations or if the serial number of the unit has been altered, defaced, or removed.

Limit of Liability. The limit of liability of SCC toward the exchange cost of the original condensing unit, F.O.B. SCC, Norton Shores, MI, of each motor-compressor assembly replaced during the warranty shall not exceed manufacturer's current established wholesaler's exchange price and in no case shall the labor of removing or replacing the motor-compressor or parts thereof be the responsibility of SCC.