

FS Series - GF Service Freezer Cases



Models

G12F
G18F
G24F

Applications

- Frozen products -2°F temperature
- Designed for gelato pans & pan inserts
- Forced air refrigeration
- Two coil design ensures proper temperature

Service freezer merchandisers for gelato products

Standard Features

- Stainless steel interior
- Painted interior
- Black trim
- Full end panels with mirror interior
- Curved double pane lift-up front glass
- Open upper rear
- Stainless steel rear ledge
- Gelato stainless steel 5 liter pans
- T-8 top light
- Electrical leads
- Levelers
- Breeze self-contained refrigeration w/ 6' power cord. (requires floor drain)
- ETL certified to CAN/CSA 22.2, conforms to UL 471 & NSF 7

Options

- Silver trim
- Cutaway end panels
- Clear glass rear sliding doors
- Night curtain
- Stainless steel 1/3 foodservice pans
- 1" bumper on front & ends
- 10" Dipwell
- Extra pan set
- Electric condensate pan (self-contained refrigeration only) (requires floor drain for weekly manual defrost)
- Price tag molding

ONE PART PASSION, TWO PARTS SCIENCE



Specifications - GF Cases

Model	LxDxH
G12F	47-3/4"Lx43-7/16"Dx53-3/4"H
G18F	67-3/4"Lx43-7/16"Dx53-3/4"H
G24F	84-3/4"Lx43-7/16"Dx53-3/4"H

Standard

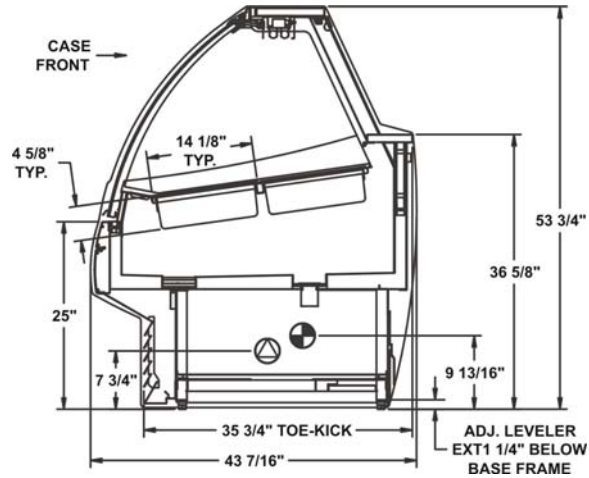

IMPORTANT NOTES

Requires floor drain.

Unit requires weekly manual defrost.

INTENDED ENVIRONMENT

Designed to operate in ambient conditions of 75°F with 55% relative humidity.

Integrated average product temperature of -2°F.

INTENDED USE

Packaged frozen products

For more information on any of our products or services please visit us on the web at: www.structuralconcepts.com

INFORMATION IS SUBJECT TO CHANGE WITHOUT NOTICE.

