

G Series - GHSSH Heated Self-Service Cases



Models

GHSS3H
GHSS4H
GHSS6H
GHSS8H

Applications

- Dry heat - 160°F
- Individually heated shelves
- For heated packaged food items

Heated self-service multi-shelf merchandisers for deli items

Standard Features

- Stainless steel interior
- Painted exterior
- Black trim
- No end panels (specify ends per lineup)
- Stainless steel rear exterior
- Lighted solid heated shelves
- Individual control for each shelf
- Front electrical access
- Electrical leads
- ETL conforms to UL 197 & NSF 4
- Meets DOE 2012 Energy Standards

Options

- Stainless steel or laminated exterior
- Silver trim
- Full w/mirror or cutaway end panels.
- Black rear exterior or clear glass rear sliding doors
- Rear electrical access (recommended with rear doors)
- 1" bumper on front
- Additional profile heights available - see back page

ONE PART PASSION, TWO PARTS SCIENCE



Specifications - GHSSH Heated Cases

Model	L*xDxH
GHSS3H	36-3/4"x 35"x 51-1/4"
GHSS4H	48-3/4"x 35"x 51-1/4"
GHSS6H	73-1/8"x 35"x 51-1/4"
GHSS8H	97-1/2"x 35"x 51-1/4"

*without 1" end panels

STANDARD

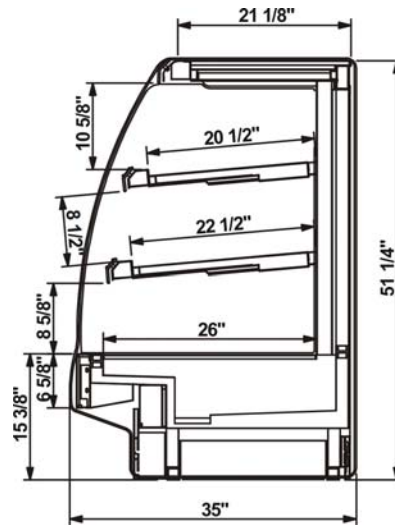

OPTIONAL HEIGHT

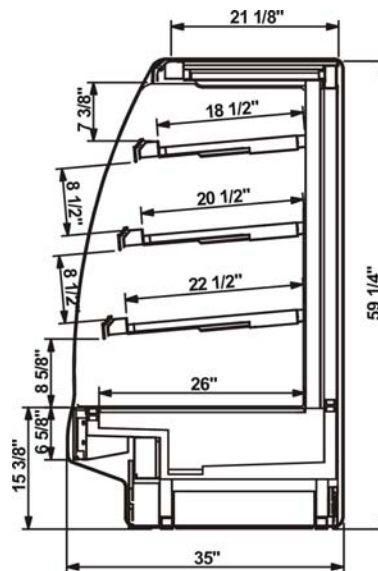

IMPORTANT NOTES

Units must be shimmed during installation to ensure the unit is level and plumb.

INTENDED ENVIRONMENT

Designed to operate in ambient conditions of 75°F with 55% relative humidity.

Integrated average product temperature of 160°F.

Designed for dry heat.

INTENDED USE

Packaged heated products.

For more information on any of our products or services please visit us on the web at:

www.structuralconcepts.com

INFORMATION IS SUBJECT TO CHANGE WITHOUT NOTICE.

