

G Series – GMBS Refrigerated Service Cases



Service mid-capacity merchandisers for bakery items

Models

GMBS3
GMBS4
GMBS6
GMBS8
GMBS12
GMBSX2
GMBSX4
GMBSX9
GMBSN2
GMBSN4
GMBSN9

Applications

- Forced air refrigeration
- Medium temperature integrated average of 41°F
- Single deck display with shelving and riser options
- For refrigerated bakery items
- Corrosion resistant stainless steel tub & fan shroud
- Designed to be used with GMBSS, GMDS & GMDSS models

Standard Features

- Black interior
- Painted exterior
- Black trim
- No end panels (specify ends per lineup)
- Curved single pane lift-up front glass
- Straight clear glass rear sliding doors - includes two shelves for increased capacity
- T-8 top & nose lights
- Electrical leads
- Energy-efficient evaporator fans
- Remote refrigeration with TXV
- ETL certified to CAN/CSA 22.2, conforms to UL 471 & NSF 7
- Meets DOE 2012 Energy Standards

Options

- White or stainless steel interior
- Stainless steel or laminated exterior
- Silver trim
- Full w/mirror, cutaway or case to case glass end panels
- Straight single pane lift-up front glass
- Straight reflective rear sliding doors
- Lighted or non-lighted solid shelf, angled display steps or 3"H full depth display risers
- LED lights
- Breeze™ self-contained refrigeration with 6' power cord - specify levelers, casters or 6"H legs
- Coated evaporator coil
- Clean Sweep® condenser coil cleaner
- Top mount scale stand with receptacle
- Rear wrapping board
- Front glass & rear door locks
- 1" bumper on front
- Price tag molding for deck and shelving
- Non-refrigerated for ambient display

ONE PART PASSION, TWO PARTS SCIENCE



Specifications - GMBS Refrigerated Cases

Model	L*xDxH
GMBS3	36-3/4"x43-3/8"x51-1/4"
GMBS4	48-3/4"x43-3/8"x51-1/4"
GMBS6	73-1/8"x43-3/8"x51-1/4"
GMBS8	97-1/2"x43-3/8"x51-1/4"
GMBS12	146-1/4"x43-3/8"x51-1/4"
GMBSX2	47-1/4"x43-3/8"x51-1/4"
GMBSX4	39-1/8"x43-3/8"x51-1/4"
GMBSX9	72-1/4"x43-3/8"x51-1/4"
GMBSN2	38-5/8"x43-3/8"x51-1/4"
GMBSN4	53-1/4"x43-3/8"x51-1/4"
GMBSN9	98-3/8"x43-3/8"x51-1/4"

STANDARD

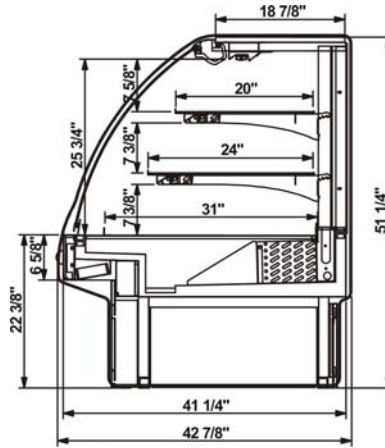

IMPORTANT NOTES

Units must be shimmed during installation to ensure the unit is level and plumb.

INTENDED ENVIRONMENT

Designed to operate in ambient conditions of 75°F with 55% relative humidity.

Integrated average product temperature of 41°F.

INTENDED USE

Unpackaged refrigerated products.

*without 1" end panels GMBSX models = convex/outside curve
GMBSN models = concave/inside curve

GMBSX2 PLAN VIEW

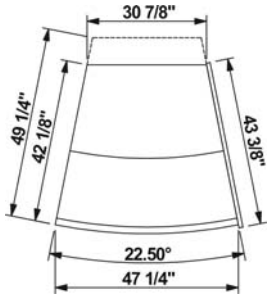

GMBSX4 PLAN VIEW

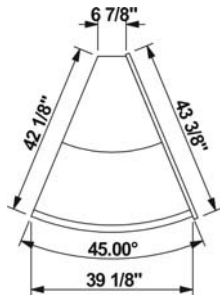

GMBSX9 PLAN VIEW

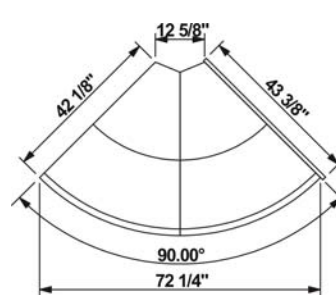

GMBSN2 PLAN VIEW

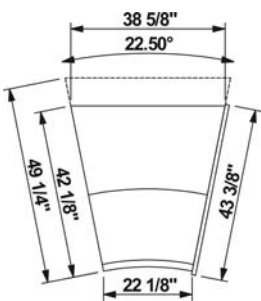

GMBSN4 PLAN VIEW

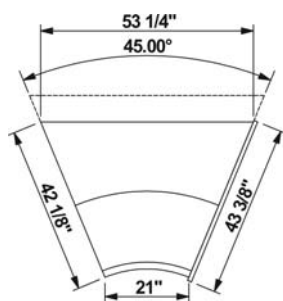

GMBSN9 PLAN VIEW

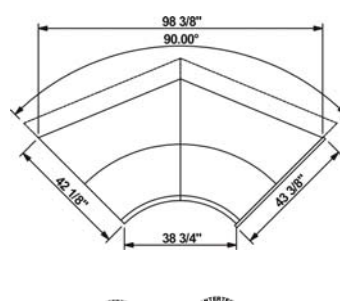

INFORMATION IS SUBJECT TO CHANGE WITHOUT NOTICE.



For more information on any of our products or services please visit us on the web at:
www.structuralconcepts.com