

G Series - GMBSS Refrigerated Self-Service Cases



Models

GMBSS3
GMBSS4
GMBSS6
GMBSS8
GMBSS12
GMBSSX2
GMBSSX4
GMBSSX9
GMBSSN2
GMBSSN4
GMBSSN9

Self-service multi-shelf merchandisers for bakery items

Applications

- Forced air refrigeration
- Medium temperature integrated average of 41°F
- For refrigerated packaged bakery items
- Designed to be used with GMBS, GMDS & GMDS models

Standard Features

- Black interior
- Painted exterior
- Black trim
- No end panels (specify ends per lineup)
- Open reach-in front
- Solid back panel
- Non-lighted solid shelves
- T-8 top light
- Electrical leads
- 19"D top header
- Energy-efficient evaporator fans
- Remote refrigeration with TXV
- ETL Certified to CAN/CSA 22.2, Conforms to UL 471 & NSF 7
- Meets DOE 2012 Energy Standards

Options

- White or stainless steel interior
- Stainless steel or laminated exterior
- Silver trim
- Full w/mirror, cutaway or case to case glass end panels.
- Clear glass rear sliding doors
- Lighted solid shelves (specify T-8 or LED)
- 1" bumper on front
- Breeze™ self-contained refrigeration with 6' power cord - specify levelers, casters, or 6"H legs
- Clean Sweep® condenser coil cleaner
- Night curtain or wire security cover
- 13" D top header
- Price tag molding
- Non-refrigerated for ambient display
- Additional profiles available - see back page

ONE PART PASSION, TWO PARTS SCIENCE



Specifications - GMBSS Refrigerated Cases

Model	L*xDxH
GMBSS3	36-3/4"x42-7/8"x51-1/4"
GMBSS4	48-3/4"x42-7/8"x51-1/4"
GMBSS6	73-1/8"x42-7/8"x51-1/4"
GMBSS8	97-1/2"x42-7/8"x51-1/4"
GMBSS12	146-1/4"x42-7/8"x51-1/4"
GMBSSX2	47-1/4"x43-3/8"x51-1/4"
GMBSSX4	39-1/8"x43-3/8"x51-1/4"
GMBSSX9	72-1/4"x43-3/8"x51-1/4"
GMBSSN2	38-5/8"x43-3/8"x51-1/4"
GMBSSN4	53-1/4"x43-3/8"x51-1/4"
GMBSSN9	98-3/8"x43-3/8"x51-1/4"

*without 1" end panels GMBSSX models = convex/outside curve
 GMBSSN models = concave/inside curve

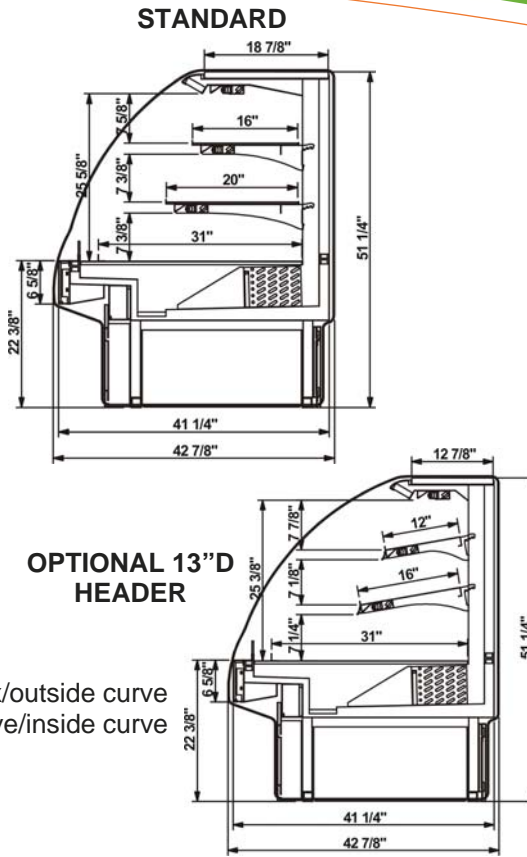

IMPORTANT NOTES

Units must be shimmed during installation to ensure the unit is level and plumb.

INTENDED ENVIRONMENT

Designed to operate in ambient conditions of 75°F with 55% relative humidity.

Integrated average product temperature of 41°F.

INTENDED USE

Packaged refrigerated products.

GMBSSX2 PLAN VIEW

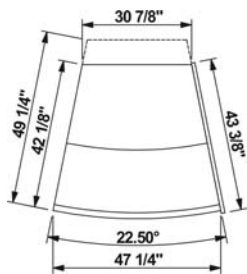

GMBSSX4 PLAN VIEW

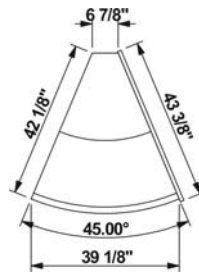

GMBSSX9 PLAN VIEW

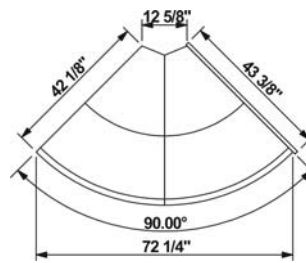

GMBSSN2 PLAN VIEW

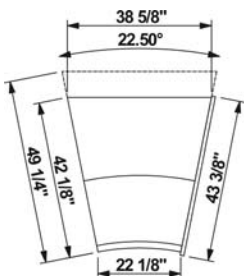

GMBSSN4 PLAN VIEW

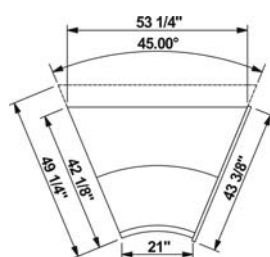

GMBSSN9 PLAN VIEW

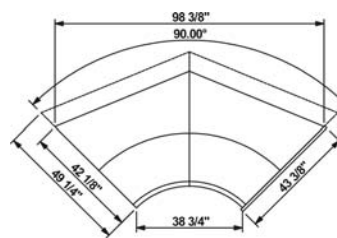

INFORMATION IS SUBJECT TO CHANGE WITHOUT NOTICE.

