

HV Series - HV Island Bakery Display Cases



Models

HV.4534
HV.4534A
HV.4534B
HV.4534C

Applications

- Self-service non-refrigerated bakery products - packaged & unpackaged

Non-refrigerated bakery island

Standard Features

- Back to back slat shelving for packaged products - 2 to 4 shelves depending on model
- Adjustable shelving with price channel
- Glass top for maximum visibility
- Laminated base
- Stainless steel toe kick
- Stainless steel bumper
- Adjustable shelves on ends - 2 to 3 depending on model
- Round baskets on ends - models HV.4534A & HV.4534B
- Self-closing glass doors - one side - model HV.4534

Options

- Choice of laminate colors
- Choice of wood finish for slatted shelves

ONE PART PASSION, TWO PARTS SCIENCE



Specifications - HV Cases

Model	LxDxH
HV.4534	108"x68"x61-1/4"
HV.4534A	112"x70-7/8"x61-1/4"
HV.4534B	112"x70-7/8"x73-1/4"
HV.4534C	130"x68"x68"

Standard
HV.4534A SIDE VIEW

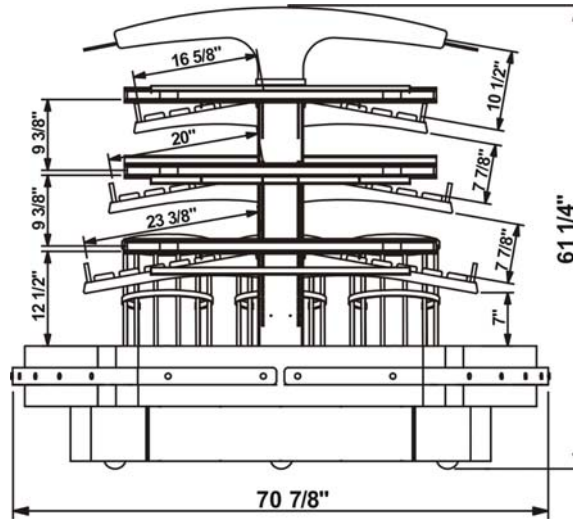

HV.4534B SIDE VIEW

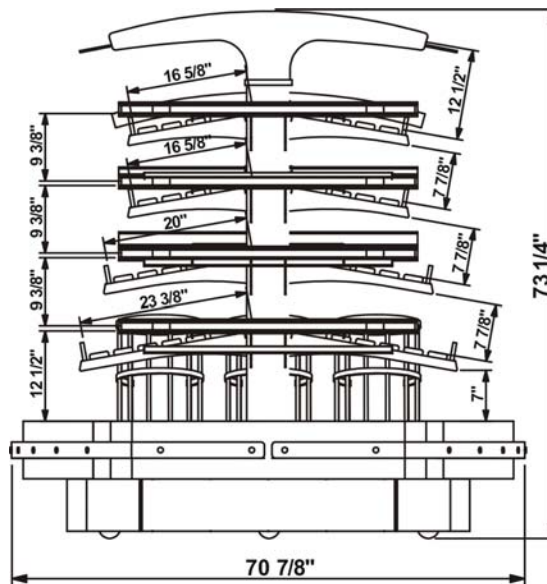

IMPORTANT NOTES

INTENDED ENVIRONMENT

Designed to operate in ambient conditions of 75°F with 55% relative humidity.

Integrated average product temperature of 41°F.

INTENDED USE

Unpackaged refrigerated products.

For more information on any of our products or services please visit us on the web at:
www.structuralconcepts.com

INFORMATION IS SUBJECT TO CHANGE WITHOUT NOTICE.

