

HV Series - HVCB In-Line Crusty Bread Cases



Models

HVCB48
HVCB56
HVCB74

Applications

- In-line merchandising of packaged bread products
- Designed to be used with HV bakery merchandisers to create continuous lineups

Low profile self-service non-refrigerated merchandisers for bread products

Standard Features

- Black interior
- Painted exterior
- White rear exterior
- Black trim
- No end panels (specify ends per lineup)
- Open front
- Open upper rear
- Non-lighted top & middle oak shelves
- Price tag molding
- Solid deck
- Levelers
- ETL certified to CAN/CSA 22.2, conforms to UL 65 & NSF 2

Options

- White interior
- Laminated exterior
- Black rear exterior
- Full or cutaway end panels
- Solid back panel
- Non-lighted or lighted top shelf with flip-up hood
- 1" bumper on front & ends
- Solid deck with product stops
- Wicker baskets for deck
- Additional profile heights available - see back page

ONE PART PASSION, TWO PARTS SCIENCE



Specifications - HVCB Cases

Model	L*xDxH
HVCB48	48"x41-1/4"x51-1/4"
HVCB56	56"x41-1/4"x51-1/4"
HVCB74	74"x41-1/4"x51-1/4"

*without 1" end panels

STANDARD

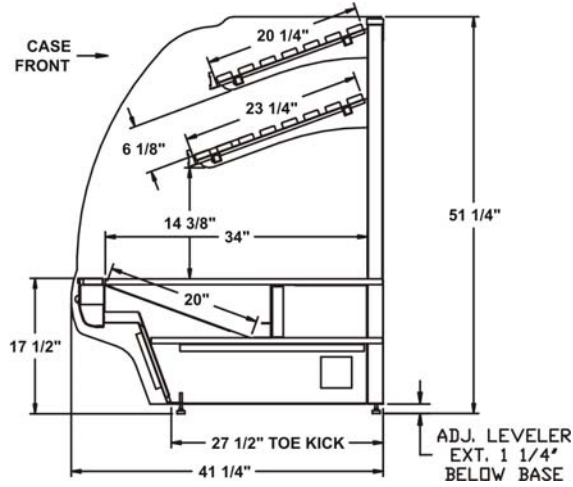

IMPORTANT NOTES

42" minimum door entry clearance required (without shipping skid).

Units are supplied with levelers which must be adjusted during installation to ensure the unit is level and plumb.

Dimensions reflect levelers extended 1-1/4".

INTENDED ENVIRONMENT

Designed to operate in ambient conditions of 75°F with 55% relative humidity.

Integrated ambient product temperature.

INTENDED USE

Packaged non-refrigerated products.

Multi Level Option

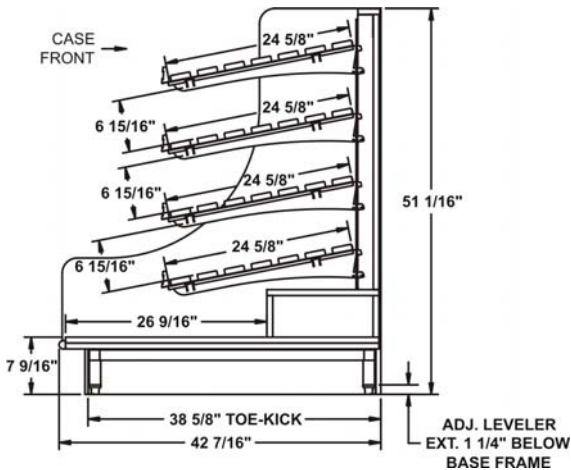

INFORMATION IS SUBJECT TO CHANGE WITHOUT NOTICE.



888 E. Porter Rd. Muskegon, MI 49441 231-798-8888

5/6/2010 REV: A

For more information on any of our products or services please visit us on the web at: www.structuralconcepts.com