

HV Series - HVOU Combination Over / Under Refrigerated Cases

Models

HVOU56RSS
HVOU74RSS
HVOU96RSS
HVOU144RSS



Refrigerated service/self-service merchandisers for bakery items

Applications

- Refrigerated service dome over refrigerated self-service base
- Forced air refrigeration
- Medium temperature integrated average 41°F

Standard Features

- Black interior
- White rear exterior
- Black trim
- Curved lift-up front glass
- Open reach-in front
- ABS curved front panel
- Clear glass rear sliding doors
- Lighted clear glass shelf in lower display
- T-8 top & shelf lights
- Electrical leads
- Levelers
- Remote refrigeration with TXV
- Non-refrigerated rear storage without door
- ETL certified to CAN/CSA 22.2, conforms to UL 471 & NSF 7

Options

- White or stainless steel interior
- Laminated or stainless steel exterior
- Black or stainless steel rear exterior
- Silver trim
- Reflective glass rear sliding doors
- All non-refrigerated or all refrigerated upper display (no convertible baffle)
- Clear glass or smoked shelf in upper display
- 6"H legs or casters
- 1" bumper front & ends
- Breeze self-contained refrigeration with 6' power cord - specify levelers, casters or 6"H legs
- Smoked glass shelf in lower display
- Price tag molding for upper & lower display areas
- Full end panels with mirror interior
- Refrigerated rear storage with doors

ONE PART PASSION, TWO PARTS SCIENCE



Specifications - HVOU Combination Over / Under Refrigerated Case

Standard

Model	L*xDxH
HVOU56RSS	56"x53-1/2"x52-5/8"
HVOU74RSS	74"x53-1/2"x52-5/8"
HVOU96RSS	96"x53-1/2"x52-5/8"
HVOU144RSS	144"x53-1/2"x52-5/8"

*without 1" end panels

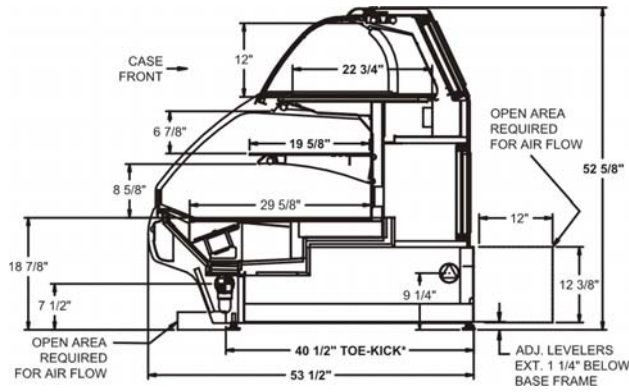

IMPORTANT NOTES

43" minimum door entry clearance required (without shipping skid).

Units are supplied with levelers which must be adjusted during installation to ensure the unit is level and plumb.

Dimensions reflect levelers extended 1-1/4".

INTENDED ENVIRONMENT

Designed to operate in ambient conditions of 75°F with 55% relative humidity.

Integrated average product temperature of 41°F.

INTENDED USE

Packaged/unpackaged refrigerated products.

For more information on any of our products or services please visit us on the web at:

www.structuralconcepts.com

INFORMATION IS SUBJECT TO CHANGE WITHOUT NOTICE.

