



# INSTALLATION & OPERATING MANUAL

PN 55009

## 33" and 35" DEEP SERVICE REFRIGERATED DISPLAY CASES

### PLEASE NOTE THE FOLLOWING:

1. YOUR SPECIFIC MODEL NUMBER IS ON THE SERIAL LABEL ON CASE REAR (NEAR MAIN POWER SWITCH).
2. SEE "MODELS (AND THEIR RESPECTIVE CASE DIMENSIONS) LISTED IN THIS MANUAL" SECTION FOR ADDITIONAL INFORMATION REGARDING SPECIFIC CASE DIMENSIONS OF STANDARD MODELS AND CDRs.

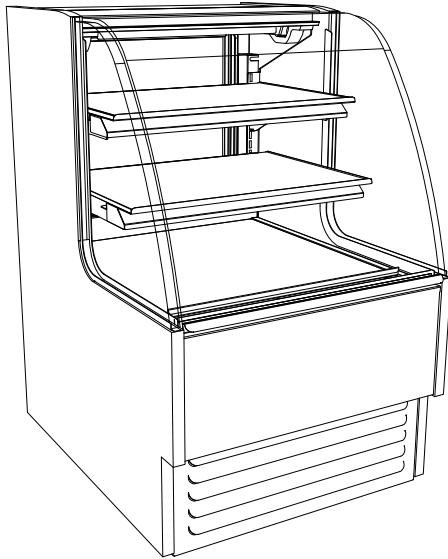

(HMG2642R.4439)  
[35" Deep Model]

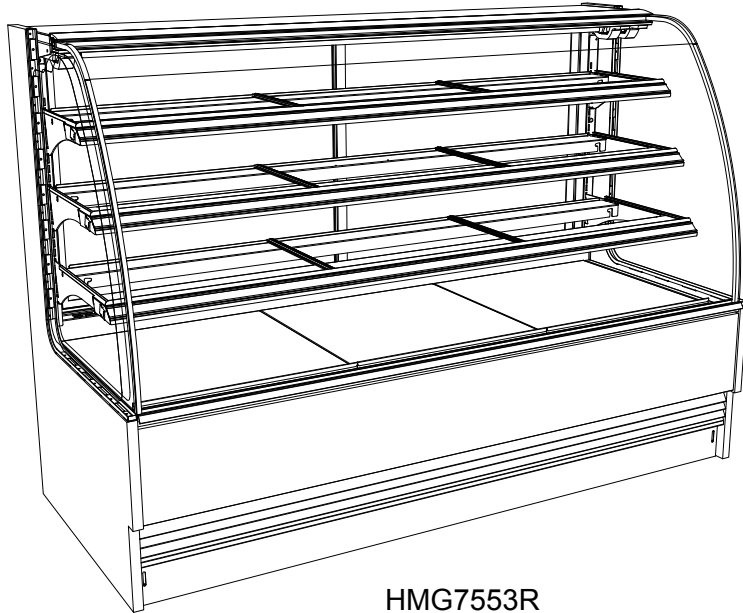

HMG7553R  
[33" Deep Model]

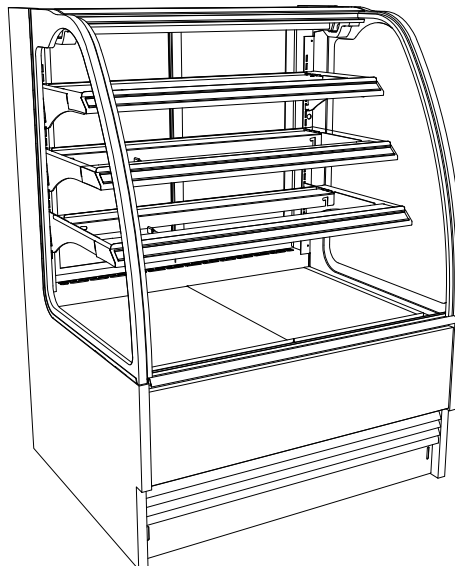

HMG3953R  
[33" Deep Model]

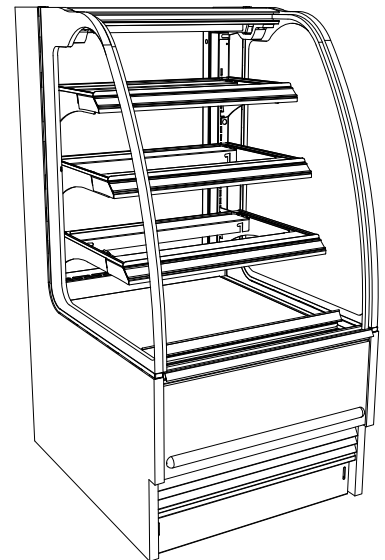

HMG2653R  
[33" Deep Model]



## TABLE OF CONTENTS

TABLE OF CONTENTS .....	2
MODELS LISTED IN MANUAL (AND DETERMINING THEIR RESPECTIVE CASE DIMENSIONS) .....	3
OVERVIEW AND WARNINGS .....	4
INSTALLATION: SKID REMOVAL, ADJUSTABLE FRONT TOE-KICK / REMOVABLE FRONT GRILLE.....	5
INSTALLATION: GLASS SHELVING / ELECTRICAL CONNECTIONS.....	6
INSTALLATION: REFRIG. LINES / STUB-UPS / DRAINS / WIRING DIAGRAMS / VENTILATION...	7
INSTALLATION: ELECTRICAL CONNECTIONS / CASTERS / ADJUSTING LEVELERS.....	8
INSTALLATION: TEMPERATURE CONTROLLER .....	9
INSTALLATION: FRONT GLASS ALIGNMENT & ADJUSTMENT.....	10
RAISING THE CURVED GLASS / OPENING REAR DOOR / REMOVING REAR DOORS .....	11
DRAIN, HOSE AND BRACKET PLACEMENT ILLUSTRATIONS .....	12
MAINTENANCE FUNDAMENTALS - STANDARD LIGHT FIXTURES .....	13
MAINTENANCE: REFRIGERATION PKG., TEMP. CONTROLLER, EVAPORATOR PAN ACCESS	14
CLEANING SCHEDULE - TO BE PERFORMED BY STORE PERSONNEL .....	15
TROUBLESHOOTING - GENERAL ISSUES .....	16-18
TROUBLESHOOTING - CONDENSING SYSTEM .....	19
TROUBLESHOOTING - EVAPORATOR SYSTEM .....	20
PREVENTIVE MAINTENANCE (TO BE PERFORMED BY TRAINED SERVICE PROVIDER) .....	21
SERIAL LABEL INFORMATION & LOCATION .....	22
TEMPERATURE CONTROLLER - CAREL® .....	23-25
TECHNICAL SERVICE CONTACT INFORMATION & WARRANTY INFORMATION .....	26

## MODELS LISTED IN THIS MANUAL (AND DETERMINING THEIR RESPECTIVE CASE DIMENSIONS)

### ***DETERMINING YOUR MODEL AND ITS CASE DIMENSIONS:***

Note 1. Your model number can be found on serial label at rear of case (near main power switch).

Note 2. Dimensions of most models can be found at [www.structuralconcepts.com](http://www.structuralconcepts.com). Simply enter the case model number into the Product Number Search box. Click the ***product specification*** link for complete dimensions.

Note 3. If your specific model is not found, contact technical service (phone number is listed at Technical Service section in this manual) for dimensions.

Note 4. CDRs (Customer Design Requests) are listed with a 4-digit number. All CDR dimensions are identical to standard model dimensions.

### ***THIS OPERATING MANUAL ENCOMPASSES THE FOLLOWING MODELS (AND THEIR RESPECTIVE CDRs):***

**Model HMG2653R  
Model HMG3953R  
Model HMG5153R  
Model HMG6353R  
Model HMG7553R  
(33" Deep Models)**

**Model HMG2642R.4439  
(35" Deep Model)**

## OVERVIEW AND WARNINGS

### OVERVIEW

- These Structural Concepts Harmony® service cases are designed to merchandise packaged products at 41°F or less product temperatures.
- These cases should be installed and operated according to this operating manual's instructions to insure proper performance. Improper use will void warranty.

This unit is designed for the display of products in ambient store conditions where temperatures and humidity are maintained within a specific range.

- For NSF® Type 1 Conditions (most cases): ambient conditions are to be at 55% max. humidity / 75°F.
- For NSF® Type 2 Conditions: ambient conditions are to be at 60% maximum humidity / 80°F.
- If unsure if your case is Type 1 or Type 2, contact Structural Concepts Technical Service (see Technical Service section in this manual for phone number).

**Caution:** Do not allow air conditioning, electric fans, open doors or windows to create air currents around display case as this may detrimentally affect proper case temperatures and operation.



**ATTENTION INSTALLER**  
This equipment must be installed in compliance with all applicable NEC, federal, state and local plumbing codes.



**WARNING**  
Risk of electric shock.  
Disconnect power before servicing unit



**WARNING**  
More than one source of electrical supply is employed with units that have separate circuits.  
Disconnect all sources before servicing.



**WARNING**  
Hazardous moving parts. Do not operate unit with covers removed.  
Fan blades may be exposed when deck panel is removed.  
Disconnect power before removing deck panel.



**WARNING**  
Evaporator Pan is Hot! Disconnect and allow to cool before cleaning or removing from case.



**CAUTION**  
Lamps have been treated to resist breakage and must be replaced with similarly treated lamps.

## INSTALLATION: SKID REMOVAL, ADJUSTABLE FRONT TOE-KICK / REMOVABLE FRONT GRILLE

### 1. Remove Case From Skid (Levelers)

- Remove shipping brace that may be securing case to skid.
- Support case to prevent tipping.
- **Caution! Levelers can be damaged if case hits floor with heavy force!**
- Carefully slide unit to rear of skid and tip backward off skid.
- Illustration may not reflect every feature or option of your particular case.

← Slide Skid Out

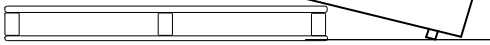

Case can be repositioned with pallet truck when front lower panel is removed. Blocking may be necessary to obtain adequate height.

### 2. Remove Case From Skid (Casters)

Remove shipping brackets that may be securing casters to skid

- Place ramp up against skid (to allow case to smoothly slide off from skid).
- Maintain support of case at all times or center of gravity may cause case to fall.
- Unlock Casters. Roll unit to rear of skid.

Roll down ramp and off from skid.

*Note: Illustrations shown reflect a general outline of sample cases and do not reflect features or options of your particular model.*

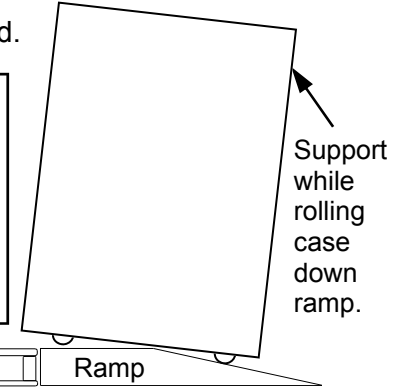

### 3. Adjustable Front Toe-Kick / Removable Front Grille

- Front toe-kick is adjustable. Simply loosen screws (one at each end) and adjust accordingly.
- To remove front grille, remove screws located at underside of front panel. This will allow access to drain line or refrigeration lines.
- Front Grille will fall forward and can be lifted up and away from case.
- Replace Front Grille in reverse order it was removed from case.
- **Note:** Illustration below may not reflect every feature or option of your particular case.

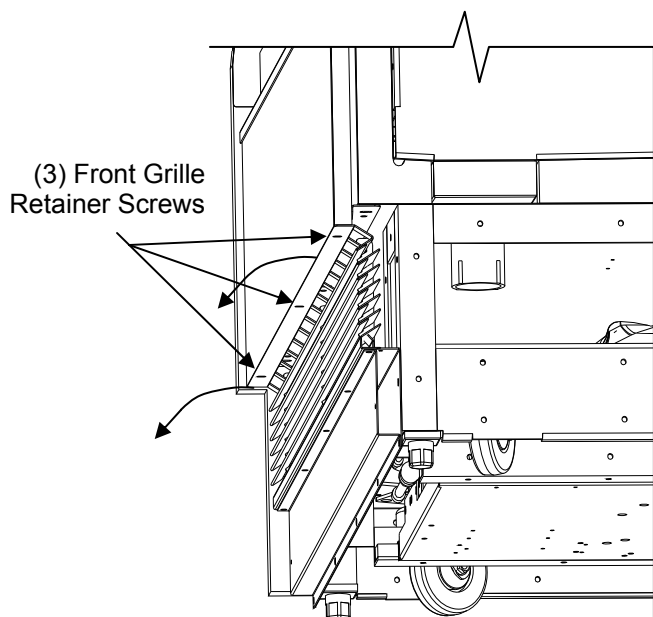
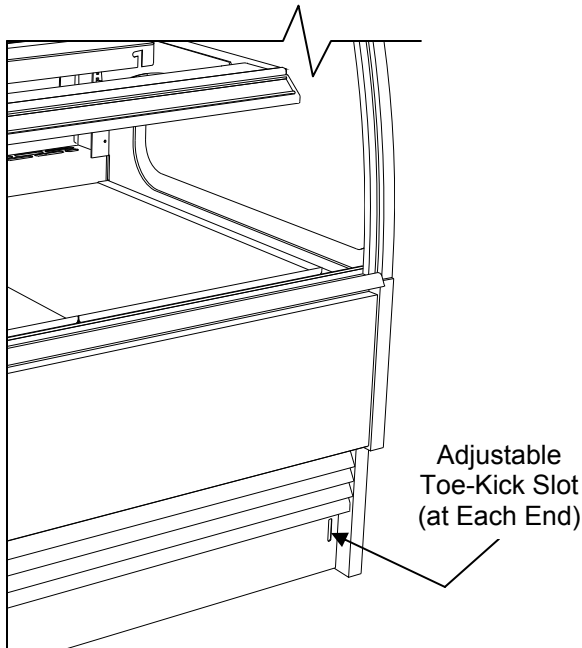

## INSTALLATION: GLASS SHELVING / ELECTRICAL CONNECTIONS

### 4. Glass Shelving

Glass shelving will be packed separately.

- Caution! Carefully remove from packaging.
- Grasp firmly and carefully install.
- *Caution! Check that plastic edging is intact before placing glass shelving onto brackets!*
- Plastic edging must NOT be removed from glass shelves. Contact Structural Concepts for replacement edging (see *TECHNICAL SERVICE CONTACT INFORMATION* section).
- Check that glass shelving is in proper position before placing product in case.
- See illustration at mid-right.

### 5. Electrical Connections

#### Remote Units

- Remove front or rear panel (by removing screws and lifting off case)

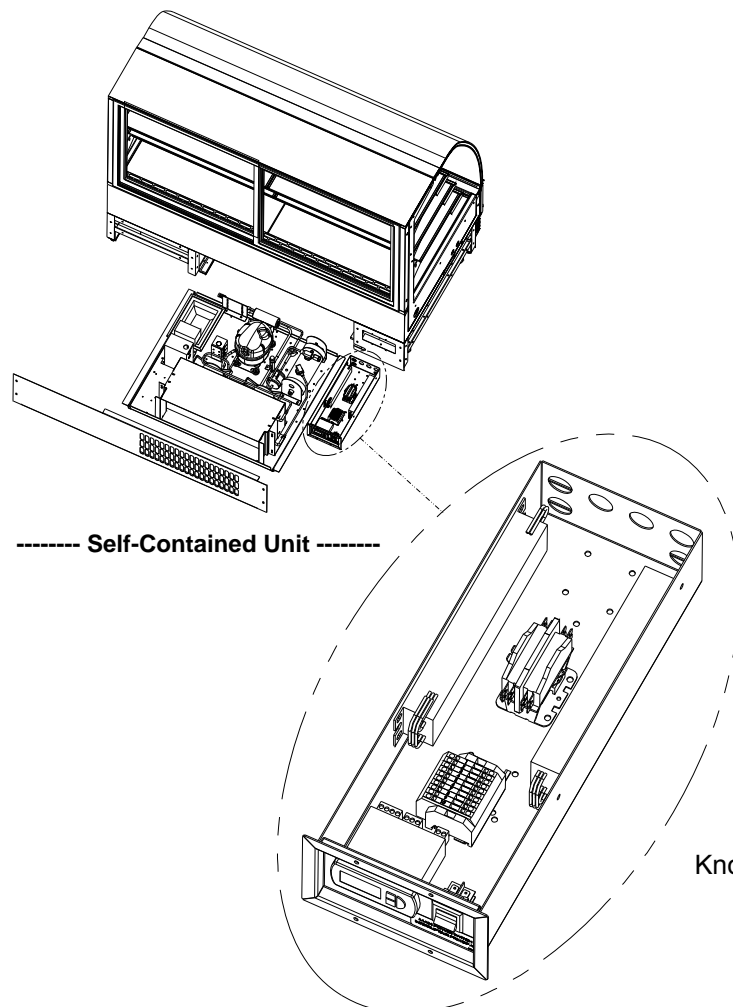

- Knockouts are located on side and rear of electrical box.
- Single phase leads are provided.
- See serial label (at case rear) for voltage rating.
- See illustration at lower-right.

#### Self-Contained Units

Field wiring connection / junction box location is at rear-right of case.

- See illustration at below-left.
- Single phase leads are provided.
- Plug unit into wall outlet.
- See serial label (at case rear) for voltage rating.

**Note:** Wiring process must be performed by certified electricians only.

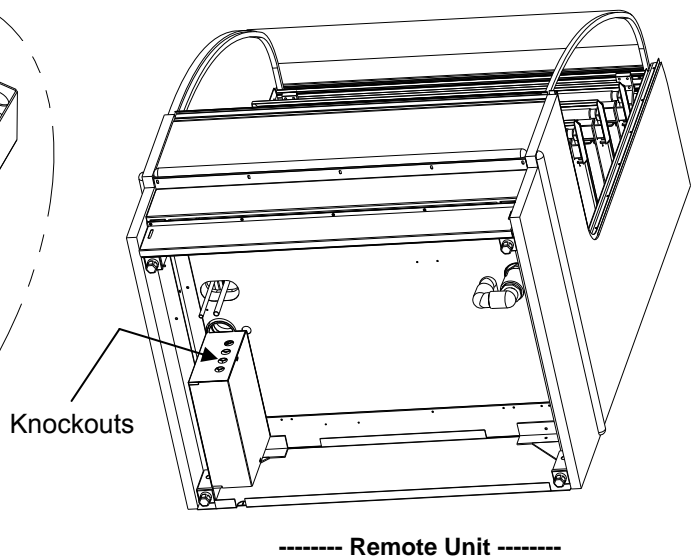
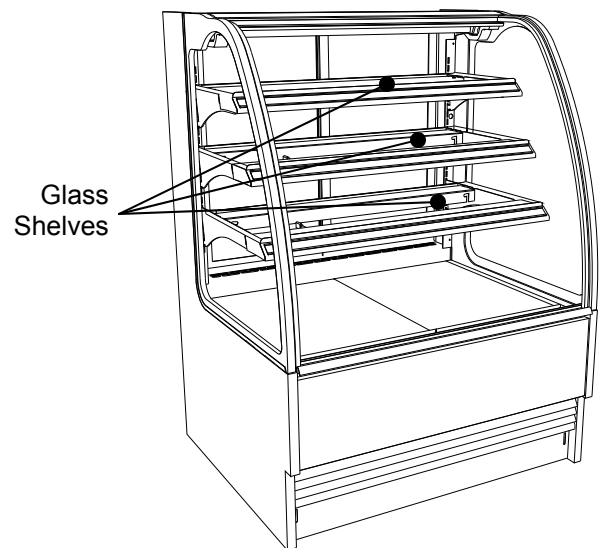

**6. Refrigeration Line Stub-Up Connections (Remote Units)**

- Remove front panel.
- Refrigerant stub-up access opening is at the front on the left hand side of the base (see illustration at top-right).
- Stub-up connections are accessed from inside the case.
  - Remove interior ABS decks.
  - Remove fan shroud assembly.
- Line connections are in the tub front, on the left hand side
- Remove foam material from the entry hole provided in the tub drain trough.
- Route refrigerant lines through access hole.
  - Run case-to-case connections through cutouts in base.
  - Sweat the high and low pressure connections.
- Fill access hole with suitable filler to insure watertight integrity of tub.
- Illustration at top-right may not reflect every feature or option of your particular case.

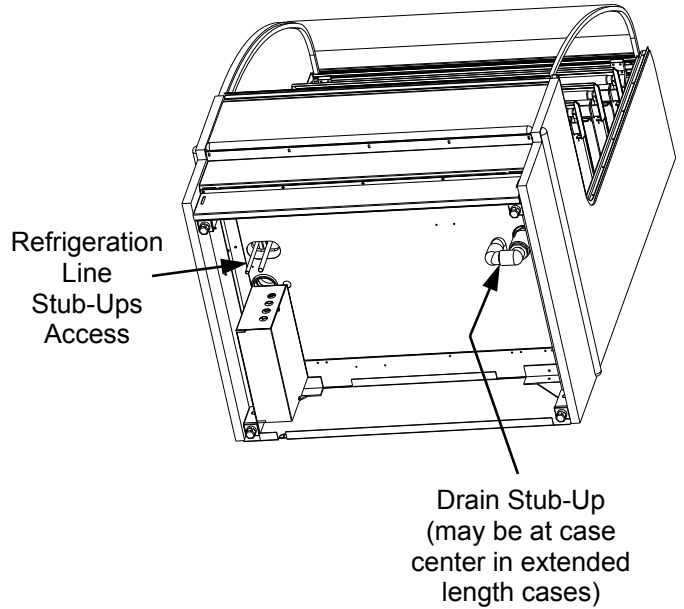

**7. Refrigeration Drain Connection (Remote Units)**

- Depending upon drain access needs, either front or rear panel may be removed to gain access to drain stub-up.
- 1.5" male PVC stub-up connection is under the case on the right hand side.
- Drain stub-up may be at case center in extended length cases.
- Connect tub drain to floor drain. Maintain 1/4"-fall per foot to provide proper drainage.
- Illustration at top-right may not reflect every feature or option of your particular case.

**8. Evaporator Pan / Drain Position (Self-Contained Units)**

- Remove rear panel (by removing screws).
- Slide the Condenser Unit out from case.
- Condenser Unit access is now available.
- Insure that the evaporator pan is installed under the PVC condensate drain trap.
- Insure that the evaporator pan is plugged into the receptacle inside base.
- Lower rear panel back into place.

- See ***Drain, Hose and Bracket Placement*** section in Operating Manual for details.

**9. Electrical Wiring Diagram**

- Each case has its own wiring diagram folded and in its own packet.
- Wiring diagram placement may vary; it may be placed near condenser fan cover, ballast box, raceway cover, or other related location.

**10. Ventilation and Clearance**

- **Self-Contained** refrigerated cases must maintain airflow clearance of 6" (minimum) to 12" (recommended) at front and rear.
- Restriction of air can void warranty.
- Illustration below may not reflect every feature or option of your particular case.

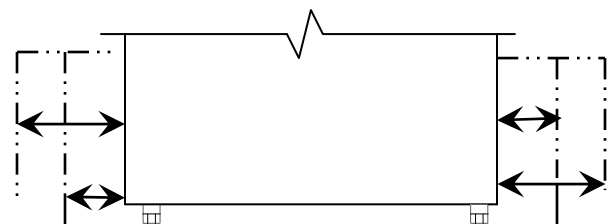

Check air grilles for obstructions. Maintain airflow clearance of 6" (min.) to 12" (recommended) at front & rear.

### 11. Display Case Start-Up

- Remote Units: Case is hard-wired. When power is supplied, case will power-up.
- Self-Contained: Main Power switch on all units are located at case rear, lower right.
- Self-Contained: Temperature Controller is located at case rear, lower right.
- Turn on the lights. Whether Remote or Self-Contained, light switch is located on inside of case at top right, from case rear.
- All lights should come on at same time. First time lighting may require short warm up period for bulbs. Slightly dim/flickering of new bulbs is normal.
- The lighting is wired in series so **all lights must be plugged in or receptacles capped** to turn on.

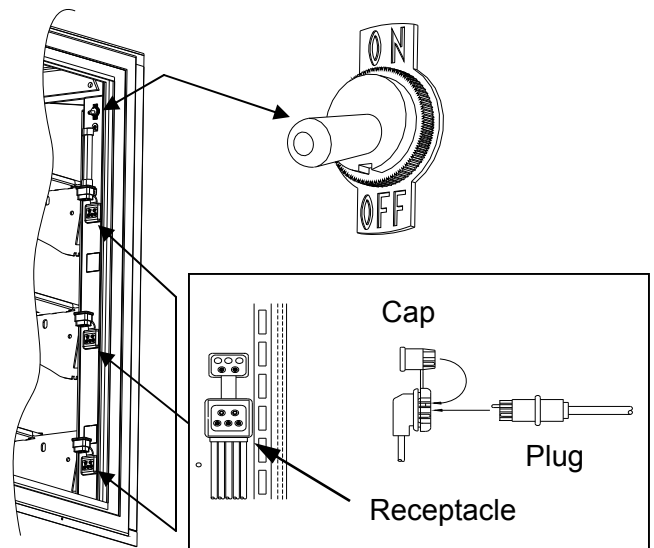

### 12. Cases With Casters: Lock and Unlock

- To lock casters, press down on lever.
- To unlock casters, pull lever up.
- See illustration at lower right.

### 13. Cases With Levelers: Adjust Levelers

- After case is in position, adjust case so it is level and plumb (see illustration at right).
- You may need to remove front and/or rear Toe-Kick to access levelers.
- Use adjustable wrench (and possibly a pry bar) to adjust leveler.
- Do not use pry bar on toe-kick (it may buckle).
- Do not use pry bar on end panel (it may chip).
- Use pry bar ONLY on base frame to avoid damaging case.
- Use a block to reach base frames with pry bar.
- See illustrations below.

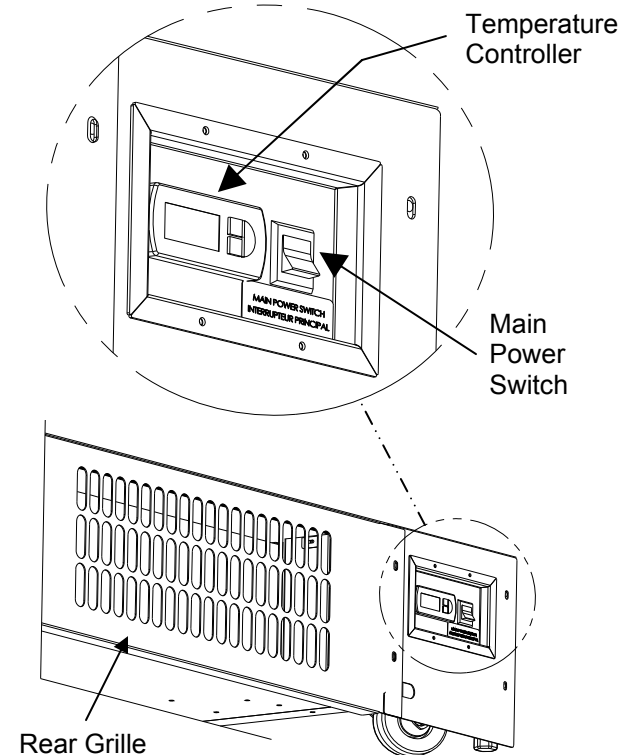

View of Case Rear, Self-Contained Unit

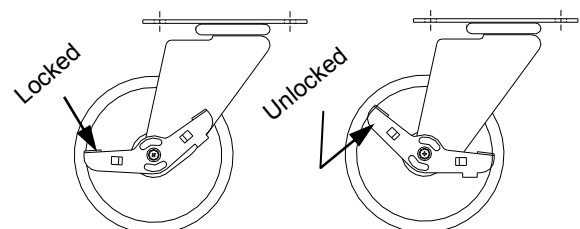
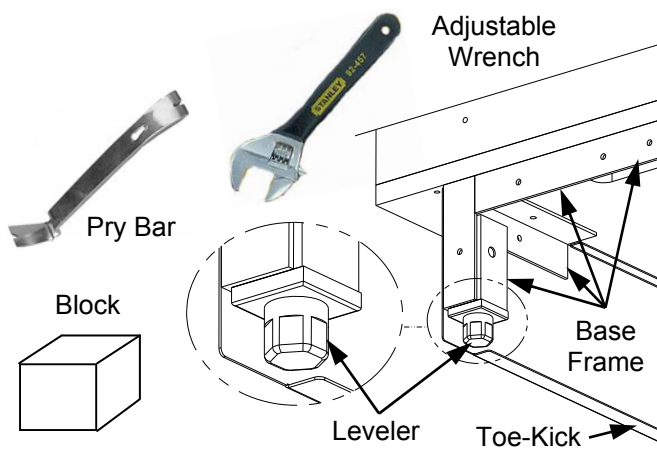

### **14. Temperature Controller (All Self-Contained Units and some Remote Units)**

- Check that compressor symbol light is on.
- SCC-Supplied temperature controller compressor is identified with:

 Compressor symbol (common in Carel® temperature controllers).

- After case has run for a few minutes, check that temperature starts to drop.
- If temperature controller does not begin cooling (in a few minutes) see temperature controller section in this operating manual for instructions.
- Remote units (without temperature controller on case): Verify that refrigeration requirements listed on serial label (found on the case) are being met.

### **15. Saturated Suction Temperature (Remote Units)**

- See serial label on case for suction temperature requirements and BTU requirements.
- See serial label on case for defrost schedule and temperature termination parameters.



Sample Carel®  
Controller Face

## INSTALLATION: FRONT GLASS ALIGNMENT & ADJUSTMENT

### 16. Front Glass Alignment & Adjustment via Levelers

- Proper alignment of the front glass is important to create and maintain a seal inside the case.
- Improper alignment can cause air leaks compromising the environment inside the case and create condensation.
- Follow the five steps listed below to assure proper front glass alignment.

**1. Side-to-Side Leveling:** Place level on top of display case (parallel to the front glass). Raise or lower either side of the case by rotating levelers to center the level bubble (following steps 3 and 4 below).

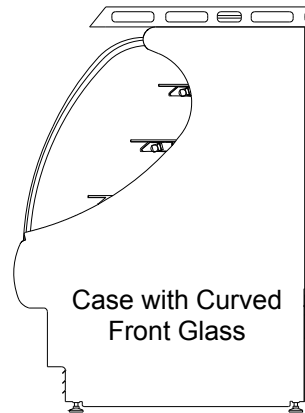

#### 2. Front-to-Back Leveling:

- Place a level on top of case, perpendicular to front glass.
- Raise or lower either side of case by rotating levelers to center the level bubble (follow steps 3 and 4).
- Double-check the side-to-side level.

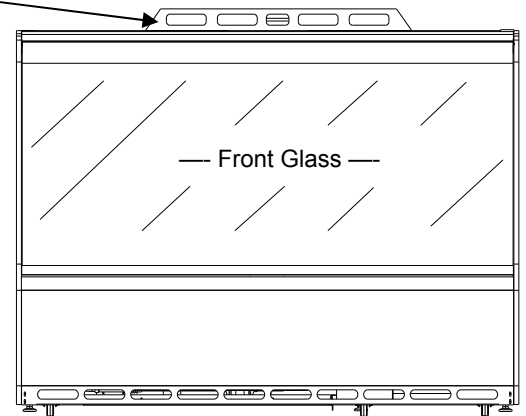

#### 3. If FRONT-LEFT CORNER is too close to end panel (or hitting it),

adjust levelers at the BACK LEFT CORNER of case DOWNWARD.

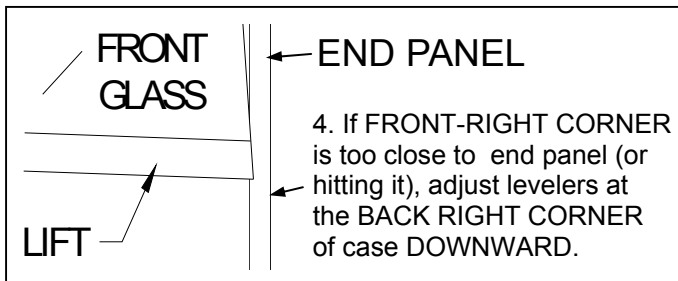
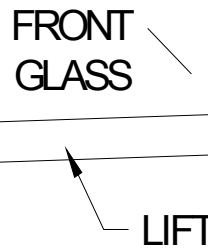

4. If FRONT-RIGHT CORNER is too close to end panel (or hitting it), adjust levelers at the BACK RIGHT CORNER of case DOWNWARD.

#### 5. Verification:

- After adjusting the levelers, open and shut the front glass.
- Verify again that front glass is properly aligned at both left-hand and right-hand side of case.
- If not, repeat the above procedure until front glass is properly aligned along both sides of case.

### 18. Front Glass Alignment & Adjustment via Clamshell Allen Screw Adjustment

- Make certain case is level and plumb.
- Lift glass to maximum upright position.
- Determine which side requires realignment.
- While maintaining grip on glass, loosen the Allen screws nearest to misaligned side.
- Adjust the glass until properly positioned.
- Allen screws may now be tightened (taunt, but not overly tightened lest glass breakage occur).
- If other side needs alignment, repeat steps while maintaining grip on glass.
- Illustrations at right may not exactly reflect every feature or option of your particular case.

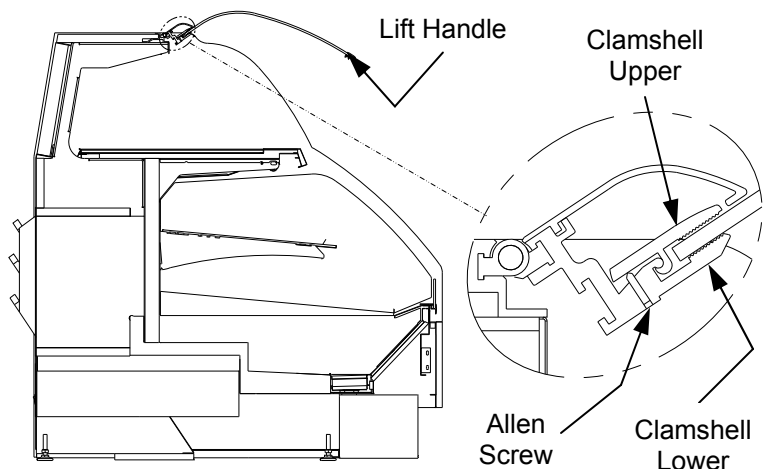

## RAISING THE CURVED GLASS / OPENING REAR DOOR / REMOVING REAR DOORS

### Raise the Curved Glass

- To raise the curved glass, secure lift handle extrusion on the bottom edge of the door and lift up.
- **Caution:** Gently return curved glass to original position.
- See illustration below.

### Opening Rear Door / Removing Rear Doors

- 26" Models have swinging clear glass door

that opens with either left hand (standard) or right hand hinge (optional).

- All other models have removable rear doors (see illustration below).
- Move rear doors toward the center of case.
- Individually lift each door up toward the top of case and pivot bottom of the door out.
- **Caution:** Gently set doors down to avoid marring, scraping, scratching or breakage.

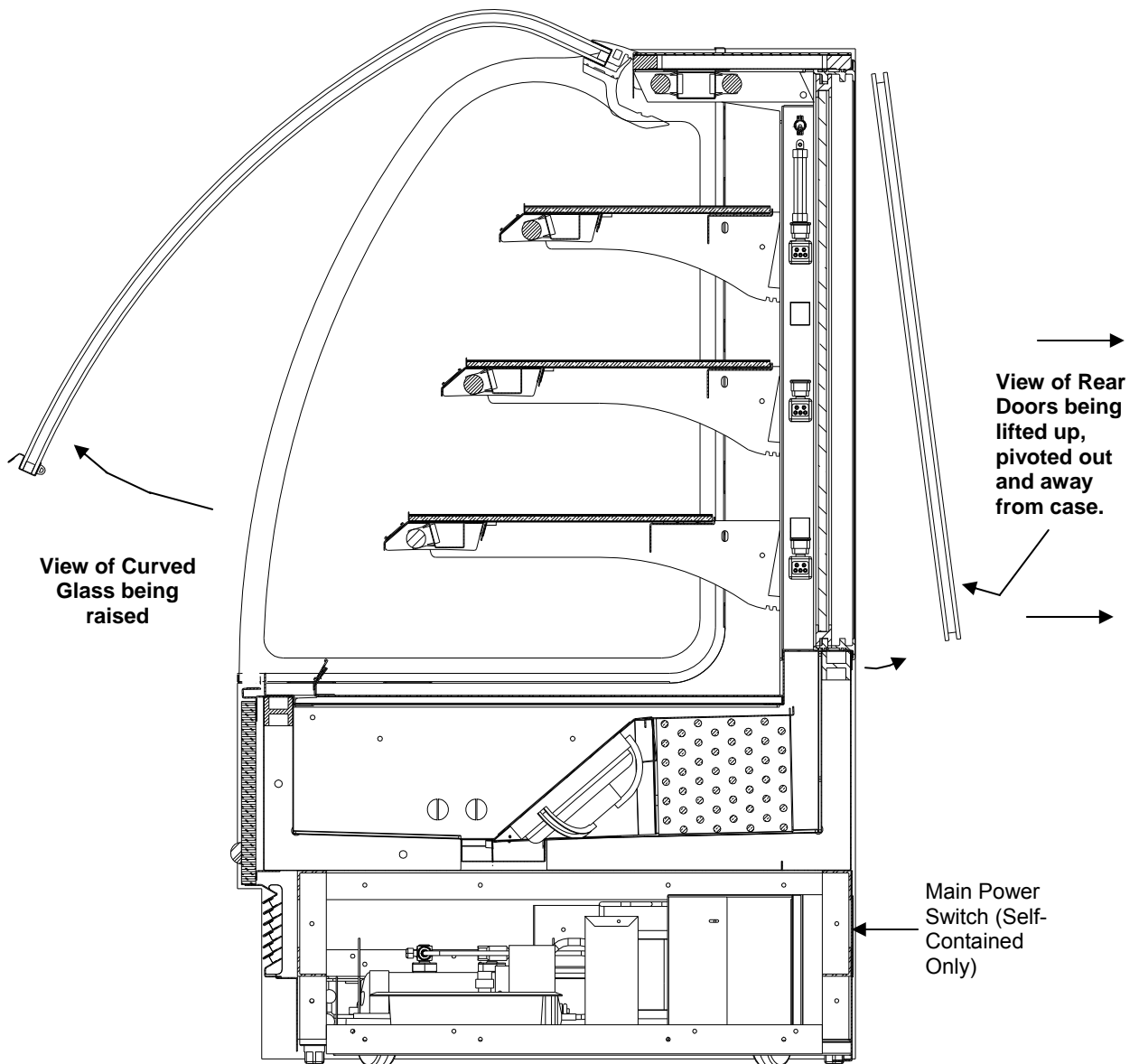

## DRAIN, HOSE AND BRACKET PLACEMENT ILLUSTRATIONS

**NOTE: BELOW ILLUSTRATIONS MAY NOT EXACTLY REFLECT EVERY PARTICULAR CASE'S FEATURES**

### Three Evaporator Systems Are Illustrated Below:

**Illustration #1:** Hot Gas "CopeVap" Evaporator System. "Copevap" is built into Compressor Unit.

**Illustration #2:** Hot Gas Evaporator System.

**Illustration 3A/3B:** Electrical Heat Rod Evaporator System. **Note:** Separate Evaporator Pan.

**Warning!** Regardless of Evaporator, the Hose and Drain Trap **MUST BE** secured and positioned over Evaporator Pan to prevent water seepage / spillage. When sliding out Condenser Unit, be careful that drain is not pulled from proper position.

### 2. Hot Gas Evaporator System.

- Hot gas serpentine coil is routed through a condensate reservoir allowing water to be heated. This system uses a wicking material (partially submersed) with warm condenser air passing through it for evaporation.
- Also incorporates an overflow reservoir with heating element to ensure complete condensate removal.

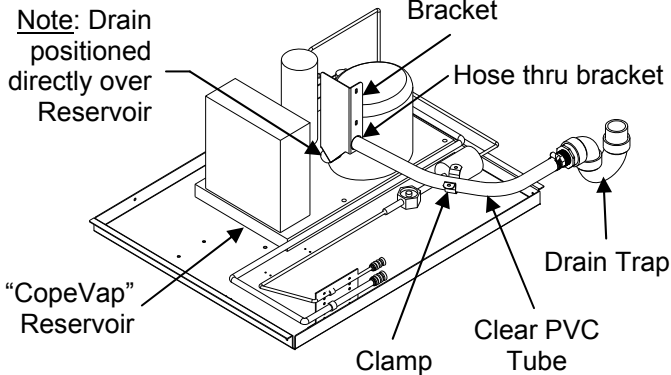
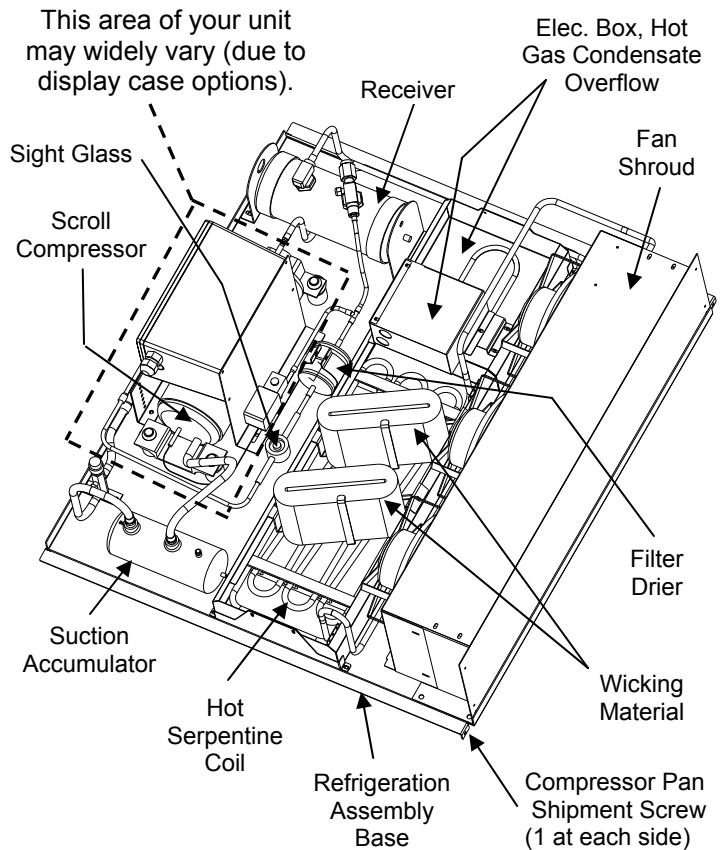

1. Hot Gas "CopeVap" Evaporator System.

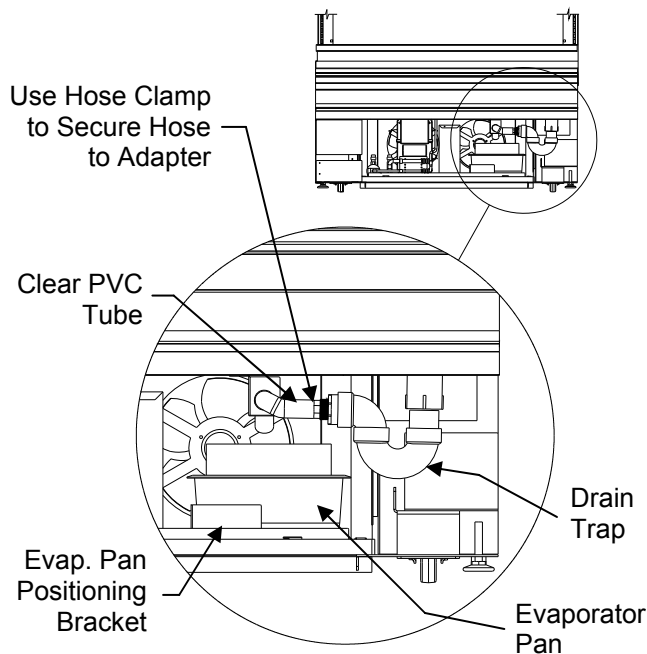

3A. Front View of Electrical Heat Rod Evaporator System

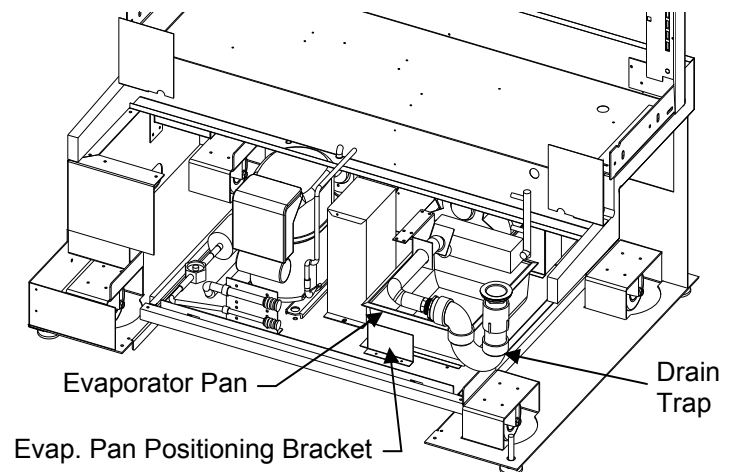

3B. Isometric View of Electrical Heat Rod Evaporator System

## MAINTENANCE: STANDARD LIGHT FIXTURES

**Note:** See *Installation* section in this manual for:

- *Front panel removal*
- *Front toe-kick adjustment*

### Light Fixtures

**Warning!** Disconnect power before providing maintenance and service to unit.

**Caution:** Lamps have been treated to resist breakage and must be replaced with similarly treated lamps.

**Note:** Warranty will be void if claims arise from negligence, misuse of goods, extreme environmental conditions or improper maintenance. See *Overview And Warnings* section in this operating manual.

Light fixtures are located on underside of shelf assemblies and at the top inside of case. See illustration at top-right for locations.

Removal of lamp:

- Rotate lamp (1/4-turn) either direction to disengage (upper or lower) pins/contacts from lamp-mounting sockets.
- Remove bulb by applying even pressure from back side at the bulb ends and pulling the remaining contact from sockets.
- See illustrations at mid and lower-right.

Installation of lamp:

- Align pins with slot.
- Insert pins into socket by rotating the bulb 1/4-turn to secure either the (upper or lower) pin contacts into the sockets.
- Rotate remaining bulb contacts (1/4-turn) into remaining lamp mounting socket contacts.
- See illustrations at right.

### Drain and Expansion Valve Access

- The drain and expansion valve are both accessible from the front of the case.
- Unplug the fans (one plug per side) and remove the fastener from the access panel in the front right (or left) corner of the unit.
- The drain and the expansion valve (TXV) are directly below the access panel.

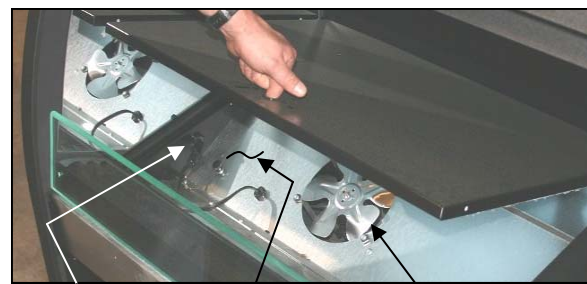
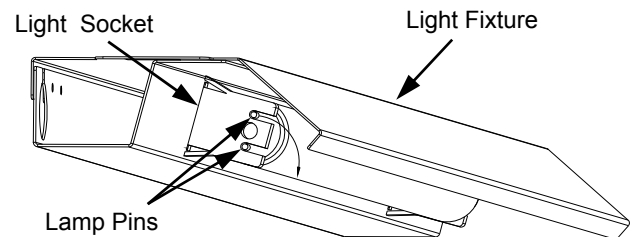
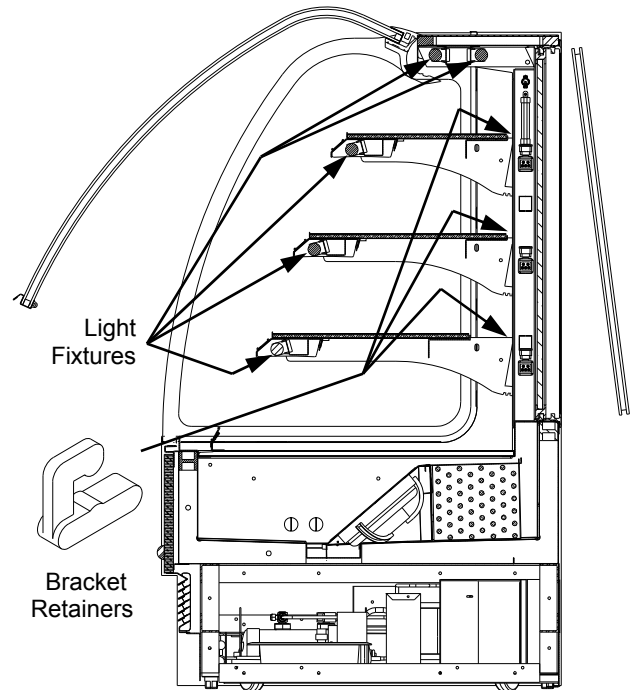

Fan Plug TXV Access Panel Evaporator Fan

### Refrigeration Package Access

**Note:** Servicing to be accomplished by licensed electrical / refrigeration contractor.

#### Air Filter

- Magnetic strips attached to the filter adhere the filter to the rear grille.
- Clean the nylon mesh filter by rinsing thoroughly with water against the air flow direction.
- Mild detergent removes smoke & grease stains.
- See illustration at top-right.

#### Pull Out Refrigeration Package

- Remove the rear grille. Grille may be slid upward and out or removal of two screws may be required.
- **Note:** At initial slide-out, it may be necessary to remove Compressor Pan Shipment Screws (see illustration at right for location).
- *Refrigerant lines are flexible to facilitate rear access maintenance.*
- Plastic glides are mounted at base to assist in sliding the condenser out for access.
- Service connections are at the left of compressor.
- Slide condenser unit out 12 to 18 inches to access high pressure service connection.

#### Temperature Controller (Self-Contained Units Only)

- Temperature Controller is located in the Ballast Box.
- Temperature / Defrost control settings are programmable from these locations.
- Case Temperature Set Point is set at the factory, as determined by case size & sensor probe location.
- Temperature is controlled by thermostat.
- If a temperature setting change is required, follow instructions regarding Temperature Control Programming Steps in the technical information section of this operating manual.
- If service is required to the temperature control unit, call Structural Concepts Corporation. Maintenance should be performed by a certified technician.

- The toll-free number is listed in the Technical Service section of this manual.
- See Temperature Controller section in this manual.

**NOTE:** Spirit-filled thermometers located in the refrigerated compartment are for monitoring warmest air temperature in accordance with NSF Std. 7

#### Evaporator Pan Access / Removal

- Turn off main power; allow evaporator pan to cool.
- Lift Rear Grille up and off (no tools required).
- **WARNING! Evaporator Pan May Be Hot!** Check temperature of pan prior to handling.
- Withdraw evaporator pan from the right side behind electrical box.
- Unplug evaporator pan from the electric outlet.
- Empty evaporator pan contents into suitable container. Replace rear panel when completed.

The Illustration below may not depict an exact representation of your particular unit.

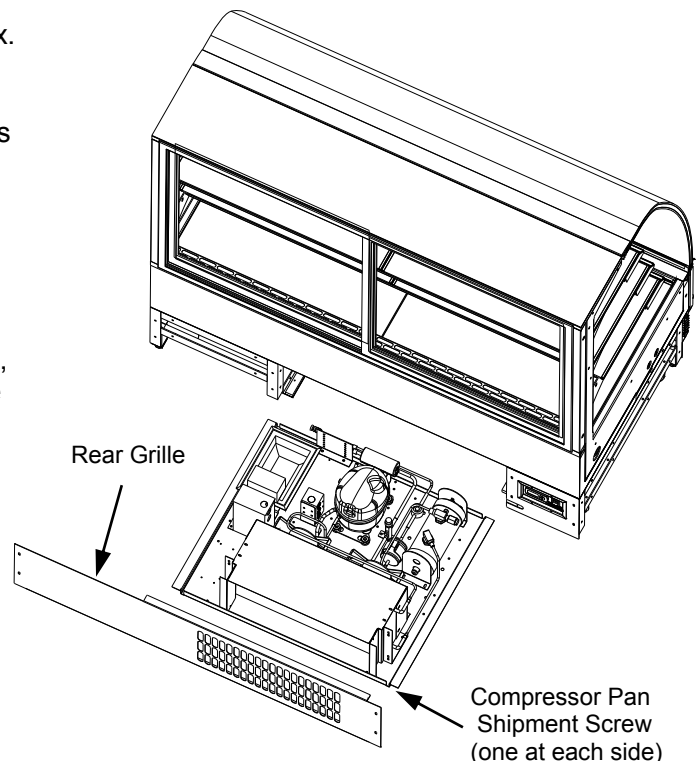

**CLEANING SCHEDULE - TO BE PERFORMED BY STORE PERSONNEL**

AREA	FREQ.	INSTRUCTIONS
Exterior	Daily	<b>All Glass / Mirrors:</b> Clean side glass, front glass, glass shelves, and mirrors with household or commercial glass cleaner. Clean out door track with moist cloth.
	Daily	<b>Rear Sliding Door Exterior Glass:</b> Clean with household or commercial glass cleaner.
	Daily	<b>End Panels, Front Panel, Toe-Kick, etc.:</b> Wipe off all surfaces with warm water and mild soap solution and non-abrasive cloth.
	Weekly	<b>Wood, Laminate and Painted Surfaces:</b> Clean with mild soap and water solution and a soft cloth .
	Weekly	<b>Acrylic:</b> Clean with warm water, mild soap solution and soft cloth; acrylic cleaning solutions are also available. Caution! Never use ammonia-based cleaners on acrylic. Incorrect cleaning agents or abrasive cleaning cloths cause surface to 'cloud' over time.
	Weekly	<b>Air Filter (with Magnetic Strips) on Rear Grille:</b> Remove air filter. Rinse with hot water against air flow direction. Use mild detergent to remove smoke and grease stains.
	Monthly	<b>Condensing Coil:</b> Remove rear grille. Vacuum or brush grille area on back of case; clean dust and dirt collecting on condenser coil. Avoid damaging fins.
	Monthly	<b>Under Case Cleaning:</b> Remove front toe-kick (or rear grille). Vacuum under case to remove all dust and dirt. Replace front toe-kick (or rear grille) when complete.
Interior	Weekly	<b>Decks:</b> Wipe off decks with moist cloth dipped in mild soap and water solution.
	Monthly	<b>Tub and Drain:</b> Keep clean and free of debris which could clog tub and drain. To access drain area, remove the deck and fan shroud. <ul style="list-style-type: none"> <li>• Vacuum tub under deck.</li> <li>• Direct the drain to a floor drain or a bucket.</li> <li>• Run hose into drain to flush out debris. Carefully hose out the tub.</li> <li>• <b>Caution! Avoid splattering water over the case and surrounding areas!</b></li> </ul>
	Monthly	<b>Air Return Grille and Fan Shroud Area:</b> 1) Turn off power. 2) Remove decks from case. 3) Clean with moist cloth.

CONDITION	TROUBLESHOOTING
<b>Case Not Lining Up</b>	See Installation Section for instructions on properly aligning case (alongside other cases) and adjusting levelers.
<b>Water Is On The Floor</b>	<p><b>Caution!</b> Water on flooring can cause much damage! Until cause is determined (and repaired), following these procedures:</p> <ul style="list-style-type: none"> <li>• Use wet-dry vacuum (or mop &amp; bucket) to remove standing water.</li> <li>• Use 'catch pans' for water to drain into. Swap out regularly until case has completely drained.</li> </ul> <p><b>Note:</b> See <i>Drain, Hose and Bracket Placement Illustrations</i> sheet in this manual for views of different evaporator systems used in display cases.</p>
	Check that the drain trap is free of debris.
	Check that the drain hose is correctly positioned over evaporator pan (or floor drain, for remote units).
	Check store conditions. To prevent condensation in NSF® Type 1 environments, maximum conditions are to be 55% humidity / 75° Fahrenheit. For NSF® Type 2, maximum conditions are to be 60% humidity / 80° Fahrenheit. See serial label (at case rear near main power switch) for NSF® Type of your case.
	Check evaporator pan float for proper operation (Heat Rod Evaporator System only).
	Check that evaporator pan is plugged in.
	<p><b>Caution!</b> Evaporator pan may be malfunctioning (Electrical Heat Rod Evaporator system). If so, water will overflow pan and seep onto flooring causing damage! Until evaporator pan is functioning (or is replaced), following these procedures:</p> <ul style="list-style-type: none"> <li>• Use wet-dry vacuum (or mop &amp; bucket) to remove standing water.</li> <li>• Use 'catch pans' for water to drain into. Swap out regularly until case has completely drained.</li> </ul>
	<p><b>Caution!</b> Disruption of power can cause water to overflow pan and seep onto flooring causing damage! Check that power to case is constant. Until power is restored, following these procedures:</p> <ul style="list-style-type: none"> <li>• Use wet-dry vacuum (or mop &amp; bucket) to remove standing water.</li> <li>• Use 'catch pans' for water to drainage. Swap out regularly until evaporation of case is complete (or until power is restored).</li> </ul> <p>When power to case is restored, evaporator pan should function properly and water will no longer overflow onto flooring.</p>
	<p>Wicking material may be dirty or worn and need replacement (Hot Gas Evaporator system).</p> <ul style="list-style-type: none"> <li>• Slide refrigeration system out from under unit.</li> <li>• After refrigeration system has been carefully slid out from under unit, replace wicking material with new. If wicking material is not available, contact Structural Concepts®. See toll-free number at last page of this operating manual.</li> </ul>

CONDITION	TROUBLESHOOTING
<b>Fan Emits Excessive Noise</b>	Check that the case is aligned, level and plumb.
	Check evaporator fan for cleanliness.
	Unplug fan motors; check motor shaft for excessive bearing wear.
	Check that fan motors are securely mounted in brackets.
	Verify that fan blades are securely mounted to fan motor.
	Check that nothing is preventing blade rotation.
	Check that the fan shroud is properly secured.
<b>Fans Are Not Working</b>	Check that the MAIN power switch (if present) is on.
	Check that fans are plugged in to fan shroud.
	Check for foreign material obstructing fan performance.
	Check that fan blades freely rotate within fan shrouds.
	Check that power is going to fans.
	Check that fan wiring is connected on terminal blocks.
<b>System Is Not Operating</b>	Check that the utility power is on.
	Check the circuit breaker box for tripped circuits.
<b>Case Is Not Holding Temperature</b>	If a large amount of warm product was added to the case, it will take time for the temperature to adjust. Product should be pre-chilled before placing in display case.
	Check Temperature Controller section in this manual.
	Check that the case is not in the sun or near a heat or air conditioning vent.
	If case is located near outside doors, temperature fluctuation can hinder unit's ability to maintain temperature.
	Check air grilles for obstructions. Maintain airflow clearance of 6" (minimum) to 12" (recommended) at case front and rear.
	Check sight glass for flashing and/or low charge.
	Check Set Point Temperature; it may be adjusted too high.

CONDITION	TROUBLESHOOTING
<b>Case Lights Are Not Working</b>	Check that Light switch is in the <b>ON</b> position (self-contained cases only). Remote case lights come on at start-up.
	Check for burned out bulbs. Turn lights off & replace.
	Clean dirt and dust from the bulbs to prevent flickering.
	Check to insure voltage at ballasts. If voltage is entering but not exiting the ballast, ballast is faulty.
	Check that <b>ALL</b> lights are plugged in and receptacles capped.
	See <b>MAINTENANCE FUNDAMENTALS - LED LIGHT FIXTURES</b> section in this manual for illustrations.
<b>Control Display Is Flashing</b>	Check Temperature Controller section in this manual.
<b>Condensing Unit Is Not Operating (Self-Contained Units Only)</b>	Check Temperature Controller section in this manual.
	Check that the power is turned on.
	Review Temperature Controller's Settings for accuracy.

**TROUBLESHOOTING - CONDENSING SYSTEM (QUALIFIED SERVICE TECHNICIANS ONLY)**

CONDITION	TROUBLESHOOTING
<b>Head Pressure Too High</b>	Check that the Condensing Coil is not dirty or covered.
	Check that Condensing Fans are working.
	Check that the refrigeration system is not overcharged.
	Check that case is free of non-condensables.
	Check that the Liquid Line Drier Filter is not plugged.
	Check Set Point temperature; it may be adjusted too high.
	Check System Operating temperatures.
	Check that Store Ambient temperature isn't above maximum allowed. See <i>Overview and Warnings</i> Section.
<b>Head Pressure Too Low</b>	Check that Refrigerant Charge isn't too low.
	Check that Suction Pressure isn't too low.
	Check to verify that Compressor Valves aren't faulty.

**TROUBLESHOOTING - EVAPORATOR SYSTEM (QUALIFIED SERVICE TECHNICIANS ONLY)**

CONDITION	TROUBLESHOOTING
<b>Low Suction Pressure</b>	Check for low refrigerant.
	Check that Expansion Valve isn't restricted.
	Check that Liquid Line or Filter isn't restricted.
	Check that Evaporator Motors are working.
	Check for Superheat setting.
	Check that the Thermostatic Element charge isn't depleted.
	Check that the Coil is not iced up.
<b>High Suction Pressure</b>	Check that Refrigerant Charge isn't too high.
	Check that Compressor Valves aren't faulty.
	Check that there is no air seepage around Condensing Coil.
	Check that the Cooling Load isn't high.
	Check that Superheat adjustment isn't low.
	Check TXV Bulb Installation a. Poor thermal contact. b. Warm location.
	Check Compressor: Low capacity means it is undersized for its application.

**PREVENTIVE MAINTENANCE (TO BE PERFORMED BY TRAINED SERVICE PROVIDER)**

**WARNING! TURN OFF CASE BEFORE PERFORMING PREVENTIVE MAINTENANCE!**

PREVENTIVE MAINTENANCE	FREQUENCY	INSTRUCTIONS
Case Exterior	Monthly	<p><b><u>Condensing Coil:</u></b></p> <ul style="list-style-type: none"> <li>• Remove Rear Grille (by removing 4 screws).</li> <li>• Use air pressure or industrial strength vacuum; clean dust and dirt that may collect on the Condenser Coil. See illustration below.</li> <li>• <b>Caution! Coil fins are sharp. Handle with care!</b></li> <li>• Replace Rear Grille to case (4 screws).</li> </ul>
	Quarterly	<p><b><u>Evaporator Pan:</u></b> <i>Caution! Disconnect from receptacle box.</i></p> <ul style="list-style-type: none"> <li>• Remove mounting screws from base.</li> <li>• Use de-scaling solution (such as CLR® that will prevent corrosion, lime and rust) to clean pan.</li> <li>• Rinse thoroughly; do not submerge in water.</li> <li>• Reattach pan to case with same mounting screws.</li> <li>• Reconnect power cord to receptacle box.</li> </ul>
	Quarterly	<p><b><u>Compressor Area:</u></b> <i>Caution! Be certain to disconnect power from case before cleaning Compressor Area!</i></p> <ul style="list-style-type: none"> <li>• Slide/Roll compressor package out from under case.</li> <li>• Use moist cloth to wipe off dust &amp; debris that collects on various parts.</li> <li>• Slide/Roll compressor package back under case.</li> </ul>
	Quarterly	<p><b><u>Under Case Cleaning:</u></b> Once refrigeration package is clear of unit, vacuum under case to remove all dust and dirt that may collect under case.</p>
Case Interior	Quarterly	<p><b><u>Tub, Coil, Drain, Fan Blades, Motors, Brackets:</u></b> <i>Disconnect power from the case before cleaning the Tub, Coil, Fan, Motor and Drain Area!</i></p> <ul style="list-style-type: none"> <li>• Remove Decking, Sub-Deck and Fan Shroud.</li> <li>• Use vacuum to clean Evaporator Coils.</li> <li>• Clean Tub, Coil and Drain with warm water, clean cloth, brush and mild soap solution.</li> <li>• Remove any debris that may clog drain.</li> <li>• Clean Fan Blades, Motors and Brackets by wiping down with moist cloth.</li> </ul>

**Serial Label Location & Information Listed / Technical Information & Service**

- Serial labels are located near the electrical access on your case.
- Serial labels contain electrical, temperature & refrigeration information, as well as regulatory standards to which the case conforms.
- For additional technical information and service, see the *TECHNICAL SERVICE* page in this manual for instructions on contacting Structural Concepts' Technical Service Department.
- See images below for samples of both refrigerated and non-refrigerated serial labels.



888 E. Porter Rd · Muskegon, MI 49441

**ENCORE<sup>®</sup>** MODEL HV74RSS SCROLL  
SERIES SERIAL NO.

**FOR PARTS AND SERVICE**  
CALL 1-800-433-9489



3048256  
CONFORMS TO UL STD 471  
CONFORMS TO NSF STD 7  
CERTIFIED TO CAN/CSA  
STD C22.2 NO 120

**ELECTRICAL RATING** 120/1/60 24A  
**REFRIGERANT** R404A AMOUNT ?? OZ  
**DESIGN PRESSURE** HIGH 450 LOW 200  
**MINIMUM CIRCUIT** 30A  
**MAXIMUM OVERCURRENT** 30A

SAMPLE ONLY

**Super Heat Temp** 8-10°F  
**BTUH Requirements** 9,738 BTUH @ 20° F SST  
**Defrost** 6 defrosts per day, 45° F termination, 45 min. failsafe

SAMPLE ONLY

SAMPLE ONLY

----- Sample Serial Label For Refrigerated Case -----



888 E. Porter Rd · Muskegon, MI 49441

**Addenda<sup>®</sup>** PC5682 txtRemote  
txtSerialNumber

120 VOLTS 60 HZ SINGLE PHASE 1.84AMP

**FOR PARTS OR SERVICE CALL**  
**STRUCTURAL CONCEPTS**  
**AT**  
**1-800-433-9489**



3048256  
CONFORMS TO UL STD 65  
CERTIFIED TO CAN/CSA  
STD C22.2 NO 120

SAMPLE ONLY

N/A

----- Sample Serial Label For Non-Refrigerated Case -----

# CAREL

**ir33 platform**  
 Integrated Electronic  
 Microprocessor Controller



## Programming The Instrument

### How To Modify The Setpoint

**Set** Press and hold the "SET" key for at least 1 second.

### How To Modify The Defrost, Differential Or Other Parameters

**Prg mute** **Set** 1. Press & hold "Prg" and "SET" keys together for at least 5 seconds; the display will show the number "0", representing the password prompt.

**Set** 2. Confirm by pressing "SET" key.

**▲ aux** **def ▼** 3. Press ▲ or ▼ to reach the category to be modified.

**Set** 4. Press "SET" to modify this selected parameter.

**▲ aux** **def ▼** 5. Increase or decrease the value using the ▲ or ▼ button respectively.

**Set** 6. Press the "SET" key to temporarily save the new value and return to the display of the parameter.

**Prg mute** 7. Press & hold the "Prg" key for at least 5 seconds to save changes. This action will also mute the audible alarm (buzzer) & deactivate the alarm relay.

### Warning! Save Your Parameter Settings!

1. To store the new parameter values, PRESS and HOLD the "Prg" key for at least 5 seconds.
2. All modifications made to parameters will be lost if you do NOT press a button within 60 seconds. Should this "timeout" occur, normal operational settings (prior to modifications being made) will resume.
3. If the instrument is switched off before pressing the "Prg" key, all modifications to parameters will be lost.

### How To Activate Manual Defrost

**def ▼** Press and hold the "def" key for at least 5 seconds.

### How To Activate / Deactivate Auxiliary Output

**▲ aux** Press and hold the "aux" key for at least 1 second.

### How To Reset Any Alarms With Manual Reset

**Prg mute** **▲ aux** Press and hold the "Prg" and "aux" key for at least 1 second.

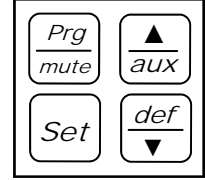

### How To Change Reading From Fahrenheit (°F) To Celcius (°C)

**Prg mute** **Set** 1. Press and hold "Prg" and "SET" keys together for at least 5 seconds; display will show "0", representing password prompt.

**Set** 2. Confirm by pressing "SET" key.

**▲ aux** **def ▼** 3. Press ▲ or ▼ until reaching the parameter "/ 5".

**Set** 4. Press "SET" to modify this selected parameter.

**▲ aux** **def ▼** 5. Press ▲ or ▼ to change value to desired setting: "0" for Celcius (°C) or "1" for Fahrenheit (°F).

**Set** 6. Press "SET" key to temporarily save the new value and return to the display of the parameter.

**Prg mute** 7. Press & hold "Prg" key for at least 5 seconds to save changes. **Note! All values will automatically convert to new scale. No conversion is required.**

# CAREL

**ir33 platform**  
**Integrated Electronic  
 Microprocessor Controller**



## User Interface - Display

ICON	FUNCTION	DESCRIPTION	ON	Normal operation OFF	BLINK	Start up
	COMPRESSOR	ON when the compressor starts. Flashes when the activation of the compressor is delayed by safety times.	Compressor on	Compressor off	awaiting activation	
	FAN	ON when the fan starts. Flashes when the activation of the fan is prevented due to external disabling or procedures in progress.	Fan on	Fan off	awaiting activation	
	DEFROST	ON when the defrost is activated. Flashes when the activation of the defrost is prevented due to external disabling or procedures in progress.	Defrost in progress	Defrost not in progress	awaiting activation	
<b>AUX</b>	AUX	Flashes if the anti-sweat heater function is active, ON when the auxiliary output (1 and/or 2) selected as AUX (or LIGHT in firmware version 3.6) is activated.	AUX auxiliary output active (version 3.6 light auxiliary output active)	AUX auxiliary output not active	Anti-sweat heater function active	
	ALARM	ON following pre-activation of the delayed external digital input alarm. Flashes in the event of alarms during normal operation (e.g. high/low temperature) or in the event of alarms from an immediate or delayed external digital input.	Delayed external alarm (before the time 'A7' elapses)	No alarm present	Alarms in norm. operation (e.g. High/low temperature) or immediate or delayed alarm from external digital input	
	CLOCK	ON if at least one timed defrost has been set. At start-up, comes ON for a few seconds to indicate that the Real Time Clock is fitted.	If at least 1 timed defrost event has been set	No timed defrost event set	Alarm clock	ON if real-time clock present
	LIGHT	Flashes if the anti-sweat heater function is active, ON when the auxiliary output (1 and/or 2) selected as LIGHT is activated (in firmware version 3.6 it does not flash in anti-sweat heater mode and comes on when the dead band output is active).	Light auxiliary output on (version 3.6 dead band auxiliary output active)	Light auxiliary output off	Anti-sweat heater function active (version 3.6 does not flash in anti-sweat heater mode)	
	SERVICE	Flashes in the event of malfunctions, for example E2PROM errors or probe faults.		No malfunction	Malfunction (e.g. E2PROM error or probe fault). Contact service	
	CONTINUOUS CYCLE	ON when the CONTINUOUS CYCLE function is activated. Flashes if the activation of the function is prevented due to external disabling or procedures in progress (E.g.: minimum compressor OFF time).	CONTINUOUS CYCLE operation activated	CONTINUOUS CYCLE function not activated	CONTINUOUS CYCLE operation requested	

## Summary Table of Alarm and Signals: Display, Buzzer and Relay

Code	Icon on the display	Alarm relay	Buzzer	Reset	Description
rE	flashing	on	on	automatic	virtual control probe fault
E0	flashing	off	off	automatic	room probe S1 fault
E1	flashing	off	off	automatic	defrost probe S2 fault
E2	flashing	off	off	automatic	probe S3 fault
E3	flashing	off	off	automatic	probe S4 fault
E4	flashing	off	off	automatic	probe S5 fault
'	No	off	off	automatic	probe not enabled
LO	flashing	on	on	automatic	low temperature alarm
HI	flashing	on	on	automatic	high temperature alarm
AFr	flashing	on	on	manual	antifreeze alarm
IA	flashing	on	on	automatic	immediate alarm from external contact
dA	flashing	on	on	automatic	delayed alarm from external contact
dEF	on	off	off	automatic	defrost running
Ed1	No	off	off	automatic/manual	defrost on evaporator 1 ended by timeout
Ed2	No	off	off	automatic/manual	defrost on evaporator 2 ended by timeout
Pd	flashing	on	on	automatic/manual	maximum pump down time alarm
LP	flashing	on	on	automatic/manual	low pressure alarm
AtS	flashing	on	on	automatic/manual	autostart in pump down
cht	No	off	off	automatic/manual	high condenser temperature pre-alarm
CHT	flashing	on	on	manual	high condenser temperature alarm
dor	flashing	on	on	automatic	door open too long alarm
EE	flashing	off	off	automatic	E2prom error, unit parameters
EF	flashing	off	off	automatic	E2prom error, operating parameters
ccb	Signal				start continuous cycle request
ccE	Signal				end continuous cycle request
dFb	Signal				start defrost call
dFE	Signal				end defrost call
On	Signal				switch ON
off	Signal				switch OFF
rES	Signal				reset alarms w/manual reset / reset HACCP alarms / reset temp. monitoring

# CAREL

## ir33 platform

Integrated Electronic  
Microprocessor Controller



### Summary Table of Operating Parameters

CODE	PARAMETER	UOM*	TYPE	MINIMUM	MAXIMUM	DEFAULT
/5	Select Celcius (°C) or Fahrenheit (°F)	flag	C	0	1	For Case Specific Defaults See Serial Label Located Near Electrical Access On Your Case.  For Additional Technical Information Call Structural Concepts Technical Service Dept. at 1(800) 433.9489
/c1	Calibration of probe 1	°C/°F	C	-20	20	
/c2	Calibration of probe 2	°C/°F	C	-20	20	
St	Temperature set point	°C/°F	F	r2	r1	
rd	Control delta	°C/°F	F	20	0.1	
dl	Interval between defrosts	hours	F	0	250	
dt1	End defrost temperature, evaporator	°C/°F	F	-50	200	
dP1	Maximum defrost duration, evaporator	min	F	1	250	
d6	Display on hold during defrost	-	C	0	2	
dd	Dripping time after defrost	min	F	0	15	
d/1	Display of defrost probe 1	°C/°F	F	-	-	

\* Unit Of Measure

STRUCTURAL CONCEPTS CORPORATION TECHNICAL SERVICE  
PHONE NUMBER: 1.800.433.9489 or For Your Master Service Agent See  
[WWW.STRUCTURALCONCEPTS.COM/Contact/Master\\_Service\\_Agents.asp](http://WWW.STRUCTURALCONCEPTS.COM/Contact/Master_Service_Agents.asp)

## WARRANTY INFORMATION

(Note: Standard Limited Warranty can be found at [www.StructuralConcepts.com](http://www.StructuralConcepts.com))

All sales by Structural Concepts Corporation (SCC) are subject to the following limited warranty. "Goods" refers to the product or products being sold by SCC.

**Warranty Scope:** Warranty is for equipment sold in the United States, Canada, Mexico and Puerto Rico. Limited warranty may apply to equipment sold elsewhere.

**Warranty; Remedies; Limitations.** SCC warrants that if any Goods are found by an authorized representative of SCC not to be of good material or workmanship within one year of the date of shipments SCC will, at its option after inspection by an authorized representative, replace any defective Good or pay the reasonable cost of replacement for any such defective Goods, provided that written notice of the defect is given to SCC within 30 days of the appearance of such defect. If notice is not given within such period, any claim for breach of warranty shall be conclusively deemed to have been waived and SCC shall not be liable under this warranty. If SCC is unable to repair or replace the defective Goods, SCC shall issue a credit to the Purchaser for all or part of the purchase price, as SCC shall determine. The replacement or payment in the manner described above shall be the sole and exclusive remedy of Purchaser for a breach of this warranty. If any Goods are defective or fail to conform to this warranty, SCC will furnish instructions for their disposition. No Goods shall be returned to SCC without its prior consent.

SCC's liability for any defect in the Goods shall not exceed the purchase price of the Goods. SCC SHALL HAVE NO LIABILITY TO PURCHASE FOR CONSEQUENTIAL DAMAGES OF ANY KIND WHATSOEVER, INCLUDING, BUT NOT LIMITED TO, PERSONAL INJURY, PROPERTY DAMAGE, LOST PROFITS, OR OTHER ECONOMIC INJURY DUE TO ANY DEFECT IN THE GOODS OR ANY BREACH OF SCC. SCC SHALL NOT BE LIABLE TO THE PURCHASER IN TORT FOR ANY NEGLIGENT DESIGN OR MANUFACTURE OF THE GOODS, OR FOR THE OMISSION OF ANY WARNING THEREFROM.

SCC shall have no obligation or liability under this warranty for claims arising from any other party's (including Purchaser's) negligence or misuse of the Goods or environmental conditions. This warranty does not apply to any claim or damage arising for or cause by improper storage, handling, installation, maintenance, or from fire, flood, accidents, structural defects, building settlement or movement, acts of God, or other causes beyond SCC's control.

Except as expressly stated herein, SCC makes no warranty, express, implied, statutory or otherwise as to any parts or goods not manufactured by SCC. SCC shall warrant such parts or Goods only (I) against such defects, (II) for such periods of time, and (III) with such remedies, as are expressly warranted by the manufacturer of such parts of Goods. Notwithstanding the foregoing, any warranty with respect to such parts of Goods and any remedies available as a result of a breach thereof shall be subject to all of the procedures, limitations, and exclusions set forth herein.

THE WARRANTIES HEREIN ARE IN LIEU OF ALL WARRANTIES, EXPRESS, IMPLIED, STATUTORY, OR OTHERWISE. IN PARTICULAR, SCC MAKES NO WARRANTY OF MERCHANTABILITY OR FITNESS FOR A PARTICULAR PURPOSE.

No representative, agent or dealer of SCC has authority to modify, expand, or extend this Warranty, to waive any of the limitations or exclusions, or to make any different or additional warranties with respect to Goods.

**Period of Limitations.** No claim, suit or other proceeding may be brought by Purchaser for any breach of the foregoing warranty or this Agreement by SCC or in any way arising out of this Agreement or relating to the Goods after one year from the date of the breach. In the interpretation of this limitation on action for a breach by SCC, it is expressly agreed that there are no warranties of future performance of the goods that would extend that period of limitation herein contained for bringing an action.

**Indemnifications.** Purchaser agrees to indemnify, hold harmless, and defend SCC if so requested, from any and all liabilities, as defined herein, suffered, or incurred by SCC as a result of, or in connection with, any act, omission, or use of the Goods by Purchaser, its employees or customers, or any breach of this Agreement by Purchaser. Liabilities shall include all costs, claims, damages, judgments, and expenses (including reasonable attorney fees and costs).

**Remedies of SCC.** SCC's rights and remedies shall be cumulative and may be exercised from time to time. In a proceeding or action relating to the breach of this Agreement by Purchaser, Purchaser shall reimburse SCC for reasonable costs and attorney's fees incurred by SCC. No waiver by SCC of any breach of Purchaser shall be effective unless in writing nor operate as a waiver of any other breach of the same term thereafter. SCC shall not lose any right because it has not exercised it in the past.

**Applicable Law.** This Agreement is made in Michigan and shall be governed by and interpreted according to Michigan law. Any lawsuit arising out of this Agreement or the Goods may be handled by a federal or state court whose district includes Muskegon County, Michigan, and Purchaser consents that such court shall have personal jurisdiction over Purchaser.

**Miscellaneous.** If any provision of this Agreement is found to be invalid or unenforceable under any law, the provision shall be ineffective to that extent and for the duration of the illegality, but the remaining provisions shall be unaffected. Purchaser shall not assign any of its rights nor delegate any of its obligations under this Agreement without prior written of SCC. This Agreement shall be binding upon and inure to the benefit of SCC and Purchaser and each of their legal representatives, successors and assigns.

SCC warrants its products to be free of defects in materials and workmanship under normal use and service for a period of one (1) year from the date of delivery.

This warranty is extended only to the original purchaser for use of the Goods. It does not cover normal wear parts such as plastic tongs, tong holders, tong cables, bag holders, or acrylic dividers.

**General Conditions.** All service labor and/or parts charges are subject to approval by SCC. Contact the Customer Service Department in writing or call 231-798-8888.

All claims must contain the following information: (1) model & serial code number of equipment; (2) the date and place of installation; (3) the name and address of the agency which performed the installation; (4) the date of the equipment failure; and (5) a complete description of the equipment failure and all circumstances relating to that failure.

Once the claim has been determined to be a true warranty claim by SCC's Customer Service Department, the following procedure will be taken: (1) replacement parts will be sent at no charge from SCC on a freight prepaid basis; (2) reimbursement for service labor will be paid if the following conditions have been met— (a) prior approval of service agency was awarded from the Customer Service Department; and (b) an itemized statement of all labor charges incurred is received by the Customer Service Department. The cost of the service labor reimbursement will be based on straight time rates and reasonable time for the repair of the defect.

If problems occur with any compressor, notify SCC's Customer Service Department immediately. Any attempt to repair or alter the unit without prior consent from the Customer Service Department will render any warranty claim null and void. This warranty and protection plan does not apply to any condensing unit or any part thereof which has been subject to accident, negligence, misuse, or abuse, or which has not been operated in accordance with the manufacturer's recommendations or if the serial number of the unit has been altered, defaced, or removed.

**Limit of Liability.** The limit of liability of SCC toward the exchange cost of the original condensing unit, F.O.B. SCC, Norton Shores, MI, of each motor-compressor assembly replaced during the warranty shall not exceed manufacturer's current established wholesaler's exchange price and in no case shall the labor of removing or replacing the motor-compressor or parts thereof be the responsibility of SCC.