

READ AND SAVE THESE INSTRUCTIONS

Addenda[®]
Merchandising Support Systems

**INSTALLATION &
OPERATING MANUAL**

PN 86772

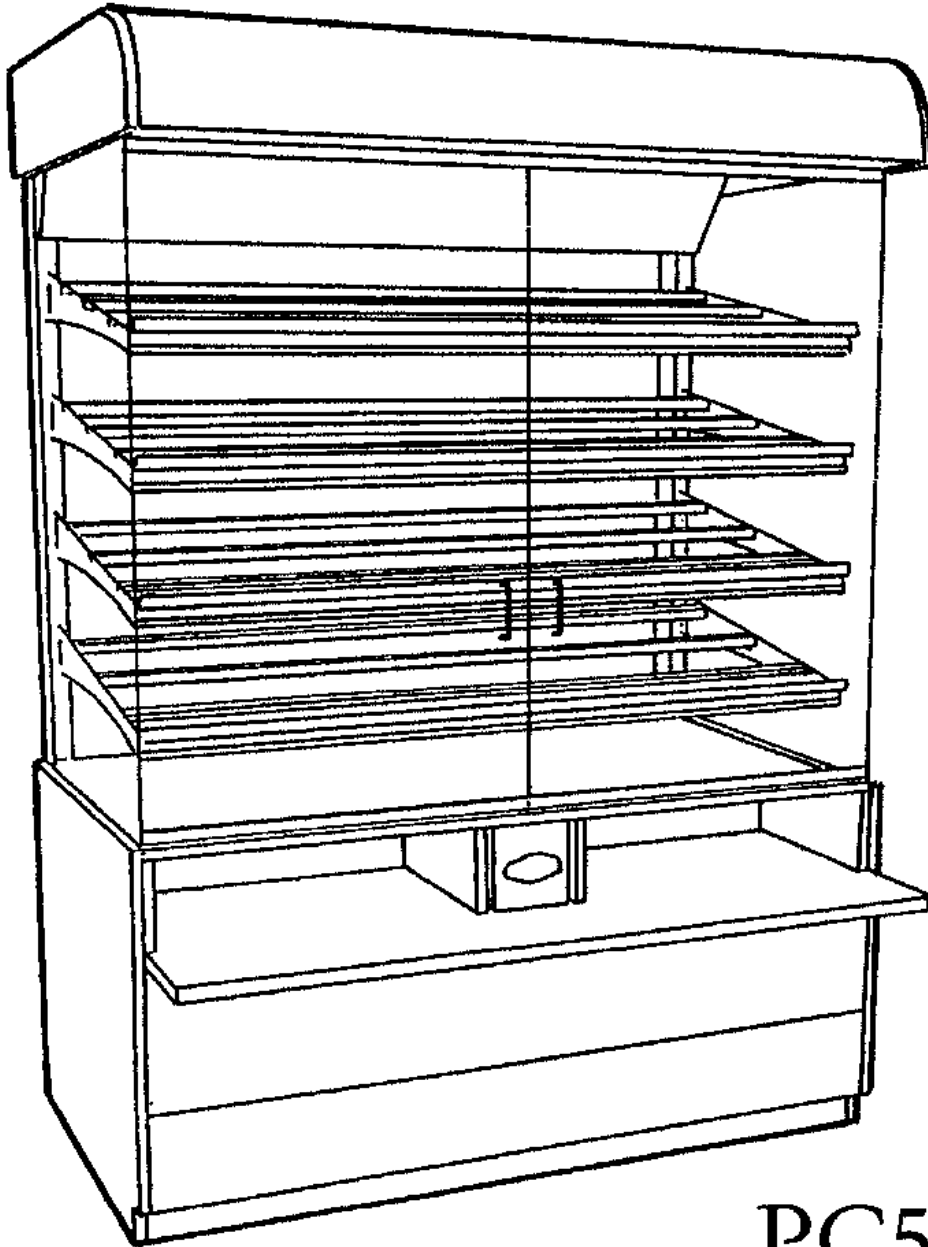

PC5682

PC7482



888 E. Porter Road · Muskegon, MI 49441 Phone: 231.798.8888 Fax: 231.798.4960 [www.structuralconcepts](http://www.structuralconcepts.com)

TABLE OF CONTENTS

INSPECTION AT ARRIVAL. REMOVAL FROM SKID.	3
MIRROR INSTALLATION / LEVELING / BOLTING / SCREWING	4
PACKAGE LEDGE ADJOINING / HEADER ADJOINING.....	5
RACK MOVING AND REMOVAL / ELECTRICAL CONNECTIONS	6
SERIAL LABEL & LOCATION / INFORMATION LISTED / ADD'L TECH INFO & SERVICE	7
WARRANTY AND LIABILITY INFORMATION	8
TECHNICAL SERVICE DEPARTMENT	9

UPON ARRIVAL

• Inspect Unit

Upon arrival and in the presence of the carrier, remove the crate and inspect the case for damage. Have the carrier note any damages onto the bill of lading.

• Report Damages

Claims for damage must be made directly with the carrier. ICC regulations require a report within 15 days of receipt. **YOU** as the receiver are responsible for filing a claim against the carrier for any damages.

REMOVING FROM SKID

- Remove shrink wrap and shipping plates.
- Tighten levelers to case.
- Slide half of case off back of skid.
- Tip case back onto rear levelers.
- Tilt case back slightly to free skid.
- Slide skid out from front of case.
- Carefully lower unit to floor.

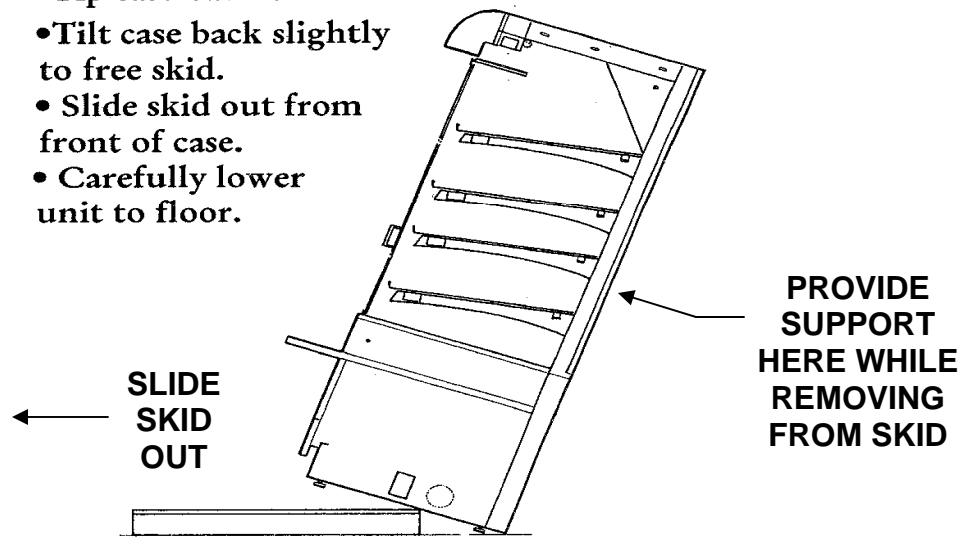

*Use caution when lifting, cases are extremely heavy.

1. Install Mirrors

- Before positioning cases, slide angled mirror in from the side of the case. See Figure 1

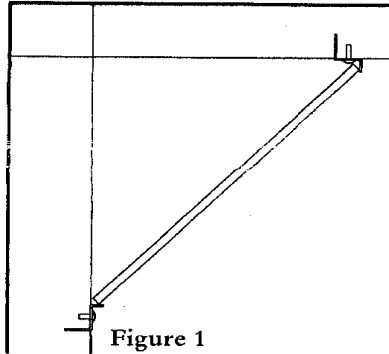

Figure 1

2. Slide Cases into Desired Position

3. Level Cases

- Level cases using wrench provided. See Figure 2 below.

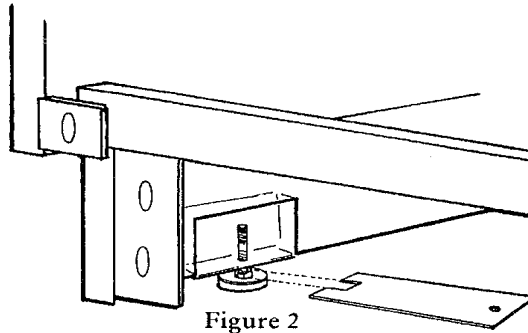

Figure 2

4. Bolt Cases Together

- Using the two 4" x .25" bolts provided, (see figure 3 below) bolt the cases together at point "A" marked with arrows on figure 5.

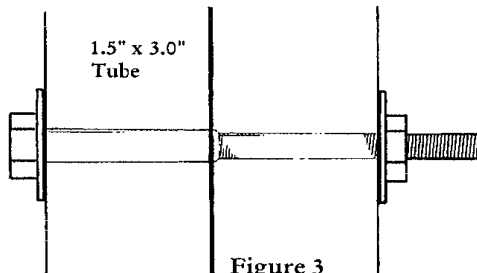

Figure 3

5. Screw cases together

- With the #10 x 1.5" flat head screw provided screw the cases together at the point marked "C" on figure 5.

6. Join Package Ledges

- With the 4"x 1.5" plate and four #10 x 5/8" screws provided in the installation kit, screw the underside of the package ledges together.

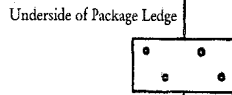

Figure 4

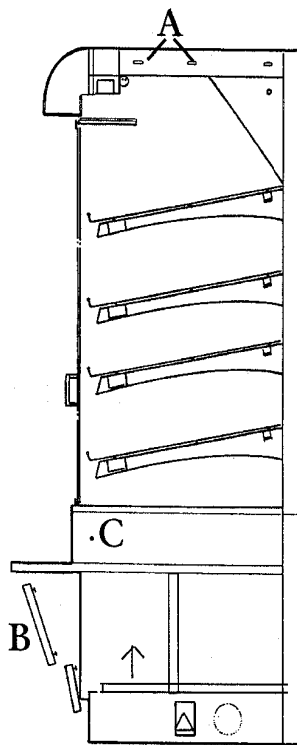

Figure 5

7. Join Headers

- Using the 2"x 3" bracket and two #10 x 1/2" slf. drill screws provided in the installation kit, join the sheet metal portions behind the header.

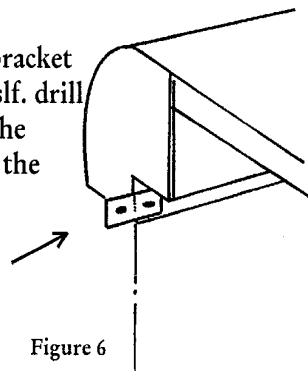

Figure 6

8. Moving or Removing Racks

- Turn off light switch.
- Unplug rack light.
- Remove racks.
- Remove rear support tube.
- Remove shelf light.
- Move bracket to desired position.

*Note all receptacles must be capped in order for case to light.

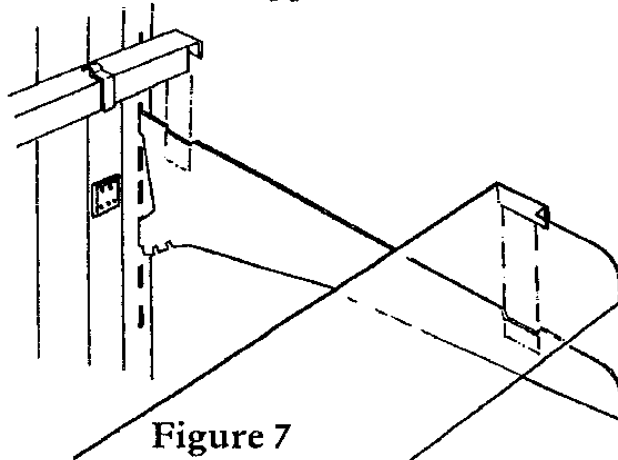



Figure 7

9. Electrical Access



- For electrical access remove the front panel.
- To remove the panel lift up and pull toward you. See Point "B" on figure 5. Then lift out inner deck to access junction box.

10. Electrical Connection



- Electrical connections are made in the base of the unit where six inch leads are provided in a connector box. 
- Standard 120 volt, single phase connection is required and should be performed by a certified electrician.

Serial Label, Location, Information Listed, Add'l Technical Info & Service

- Serial labels are located near the electrical access on your case.
- Serial labels contain electrical, temperature & refrigeration information, as well as regulatory standards to which the case conforms.
- For additional technical information and service, see the *TECHNICAL SERVICE* page in this manual for instructions on contacting Structural Concepts' Technical Service Department.
- See images below for samples of both refrigerated and non-refrigerated serial labels.

 <p>888 E. Porter Rd · Muskegon, MI 49441</p>		 <p>MODEL HV74RSS SCROLL SERIAL NO.</p>	
<p>FOR PARTS AND SERVICE CALL 1-800-433-9489</p>			
 <p>3048256</p> <p>CONFORMS TO UL STD 471 CONFORMS TO NSF STD 7 CERTIFIED TO CAN/CSA STD C22.2 NO 120</p>		<p>ELECTRICAL RATING 120/1/60 24A REFRIGERANT R404A AMOUNT ?? OZ DESIGN PRESSURE HIGH 450 LOW 200 MINIMUM CIRCUIT 30A MAXIMUM OVERCURRENT 30A</p>	
Super Heat Temp	8-10°F		
BTUH Requirements	9,738 BTUH @ 20° F SST		
Defrost	6 defrosts per day, 45° F termination, 45 min. failsafe		

----- Sample Serial Label For Refrigerated Case -----

 <p>888 E. Porter Rd · Muskegon, MI 49441</p>		 <p>PC5682 txtRemote txtSerialNumber</p>	
 <p>3048256</p> <p>CONFORMS TO UL STD 65 CERTIFIED TO CAN/CSA STD C22.2 NO 120</p>		<p>120 VOLTS 60 HZ SINGLE PHASE 1.84AMP</p> <p>FOR PARTS OR SERVICE CALL STRUCTURAL CONCEPTS AT 1-800-433-9489</p>	
			SAMPLE ONLY

----- Sample Serial Label For Non-Refrigerated Case -----

WARRANTY

All sales by Structural Concepts Corporation (SCC) are subject to the following limited warranty. "Goods" refers to the product or products being sold by SCC.

Warranty; Remedies; Limitations. SCC warrants that if any Goods are found by an authorized representative of SCC not to be of good material or workmanship within one year of the date of shipments SCC will, at its option after inspection by an authorized representative, replace any defective Good or pay the reasonable cost of replacement for any such defective Goods, provided that written notice of the defect is given to SCC within 30 days of the appearance of such defect. If notice is not given within such period, any claim for breach of warranty shall be conclusively deemed to have been waived and SCC shall not be liable under this warranty. If SCC is unable to repair or replace the defective Goods, SCC shall issue a credit to the Purchaser for all or part of the purchase price, as SCC shall determine. The replacement or payment in the manner described above shall be the sole and exclusive remedy of Purchaser for a breach of this warranty. If any Goods are defective or fail to conform to this warranty, SCC will furnish instructions for their disposition. No Goods shall be returned to SCC without its prior consent.

SCC's liability for any defect in the Goods shall not exceed the purchase price of the Goods. SCC SHALL HAVE NO LIABILITY TO PURCHASE FOR CONSEQUENTIAL DAMAGES OF ANY KIND WHATSOEVER, INCLUDING, BUT NOT LIMITED TO, PERSONAL INJURY, PROPERTY DAMAGE, LOST PROFITS, OR OTHER ECONOMIC INJURY DUE TO ANY DEFECT IN THE GOODS OR ANY BREACH OF SCC. SCC SHALL NOT BE LIABLE TO THE PURCHASER IN TORT FOR ANY NEGLIGENT DESIGN OR MANUFACTURE OF THE GOODS, OR FOR THE OMISSION OF ANY WARNING THEREFROM.

SCC shall have no obligation or liability under this warranty for claims arising from any other party's (including Purchaser's) negligence or misuse of the Goods or environmental conditions. This warranty does not apply to any claim or damage arising for or cause by improper storage, handling, installation, maintenance, or from fire, flood, accidents, structural defects, building settlement or movement, acts of God, or other causes beyond SCC's control.

Except as expressly stated herein, SCC makes no warranty, express, implied, statutory or otherwise as to any parts or goods not manufactured by SCC. SCC shall warrant such parts or Goods only (I) against such defects, (II) for such periods of time, and (III) with such remedies, as are expressly warranted by the manufacturer of such parts of Goods. Notwithstanding the foregoing, any warranty with respect to such parts of Goods and any remedies available as a result of a breach thereof shall be subject to all of the procedures, limitations, and exclusions set forth herein.

THE WARRANTIES HEREIN ARE IN LIEU OF ALL WARRANTIES, EXPRESS, IMPLIED, STATUTORY, OR OTHERWISE. IN PARTICULAR, SCC MAKES NO WARRANTY OF MERCHANTABILITY OR FITNESS FOR A PARTICULAR PURPOSE.

No representative, agent or dealer of SCC has authority to modify, expand, or extend this Warranty, to waive any of the limitations or exclusions, or to make any different or additional warranties with respect to Goods.

Period of Limitations. No claim, suit or other proceeding may be brought by Purchaser for any breach of the foregoing warranty or this Agreement by SCC or in any way arising out of this Agreement or relating to the Goods after one year from the date of the breach. In the interpretation of this limitation on action for a breach by SCC, it is expressly agreed that there are no warranties of future performance of the goods that would extend that period of limitation herein contained for bringing an action.

Indemnifications. Purchaser agrees to indemnify, hold harmless, and defend SCC if so requested, from any and all liabilities, as defined herein, suffered, or incurred by SCC as a result of, or in connection with, any act, omission, or use of the Goods by Purchaser, its employees or customers, or any breach of this Agreement by Purchaser. Liabilities shall include all costs, claims, damages, judgments, and expenses (including reasonable attorney fees and costs).

Remedies of SCC. SCC's rights and remedies shall be cumulative and may be exercised from time to time. In a proceeding or action relating to the breach of this Agreement by Purchaser, Purchaser shall reimburse SCC for reasonable costs and attorney's fees incurred by SCC. No waiver by SCC of any breach of Purchaser shall be effective unless in writing nor operate as a waiver of any other breach of the same term thereafter. SCC shall not lose any right because it has not exercised it in the past.

Applicable Law. This Agreement is made in Michigan and shall be governed by and interpreted according to Michigan law. Any lawsuit arising out of this Agreement or the Goods may be handled by a federal or state court whose district includes Muskegon County, Michigan, and Purchaser consents that such court shall have personal jurisdiction over Purchaser.

Miscellaneous. If any provision of this Agreement is found to be invalid or unenforceable under any law, the provision shall be ineffective to that extent and for the duration of the illegality, but the remaining provisions shall be unaffected. Purchaser shall not assign any of its rights nor delegate any of its obligations under this Agreement without prior written of SCC. This Agreement shall be binding upon and inure to the benefit of SCC and Purchaser and each of their legal representatives, successors and assigns.

SCC warrants its products to be free of defects in materials and workmanship under normal use and service for a period of one (1) year from the date of delivery.

This warranty is extended only to the original purchaser for use of the Goods. It does not cover normal wear parts such as plastic tongs, tong holders, tong cables, bag holders, or acrylic dividers.

General Conditions. All service labor and/or parts charges are subject to approval by SCC. Contact the Customer Service Department in writing or call 231-798-8888.

All claims must contain the following information: (1) the model and serial code number of the equipment; (2) the date and place of installation; (3) the name and address of the agency which performed the installation; (4) the date of the equipment failure; and (5) a complete description of the equipment failure and all circumstances relating to that failure.

Once the claim has been determined to be a true warranty claim by SCC's Customer Service Department, the following procedure will be taken: (1) replacement parts will be sent at no charge from SCC on a freight prepaid basis; (2) reimbursement for service labor will be paid if the following conditions have been met— (a) prior approval of service agency was awarded from the Customer Service Department; and (b) an itemized statement of all labor charges incurred is received by the Customer Service Department. The cost of the service labor reimbursement will be based on straight time rates and reasonable time for the repair of the defect.

If problems occur with any compressor, notify SCC's Customer Service Department immediately. Any attempt to repair or alter the unit without prior consent from the Customer Service Department will render any warranty claim null and void. This warranty and protection plan does not apply to any condensing unit or any part thereof which has been subject to accident, negligence, misuse, or abuse, or which has not been operated in accordance with the manufacturer's recommendations or if the serial number of the unit has been altered, defaced, or removed.

Limit of Liability. The limit of liability of SCC toward the exchange cost of the original condensing unit, F.O.B. SCC, Norton Shores, MI, of each motor-compressor assembly replaced during the warranty shall not exceed manufacturer's current established wholesaler's exchange price and in no case shall the labor of removing or replacing the motor-compressor or parts thereof be the responsibility of SCC.

**STRUCTURAL CONCEPTS CORPORATION
TECHNICAL SERVICE DEPARTMENT
1.800.433.9489**