

WAVE Series - WCCL Concave Open Low Profile Cases



Models

FLPCC22
FLPCC45
FLPCC67

Applications

- Forced air refrigeration
- Medium temperature integrated average 41°F
- For fresh cut flowers
- Designed to be used with straight and curved merchandisers to create WAVE lineups

Concave curved open low profile merchandisers for floral products

Standard Features

- Black interior
- Black exterior
- No end panels (specify ends per lineup)
- Open reach-in front
- Galvanized exterior back panel
- 13" bucket support shelves (3 levels)
- T-8 top light
- Glass upper & lower front panels
- Electrical leads
- Top electrical access
- Base rail system for shims
- Remote refrigeration with TXV piped at base
- ETL conforms to UL 471

Options

- Laminate exterior
- Full or cutaway end panels
- Black exterior back panel
- 10" bucket support shelves (3 levels)
- Front electrical access
- 2" bumper on ends
- Fresh Flow® automatic watering system

ONE PART PASSION, TWO PARTS SCIENCE



Specifications - WCCL Concave Open Low Profile

Model	LxDxH
FLPCC22	49-5/8"x44-3/16"x50-9/16"
FLPCC45	94 5/8"x44 3/16"x50 9/16"
FLPCC67	136 1/2x44 3/16x50 9/16

Bucket Capacities		
Model	Standard Configuration	W/ Optional Fresh Flow System
FLPCC22	(11) 9"D x 10"T	(12) 8"D x 13"T
FLPCC45	(23) 9"D x 10"T	(25) 8"D x 13"T
FLPCC67	(37) 9"D x 10"T	(37) 8"D x 13"T

STANDARD

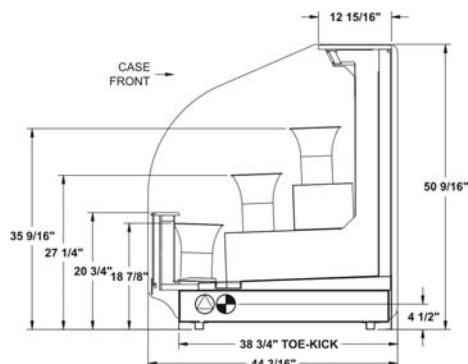

IMPORTANT NOTES

INTENDED ENVIRONMENT

Designed to operate in ambient conditions of 75°F with 55% relative humidity.

INTENDED USE

Refrigerated floral products

Plan View - FLPCC22

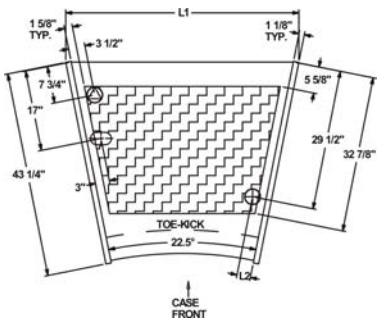

Plan View - FLPCC45

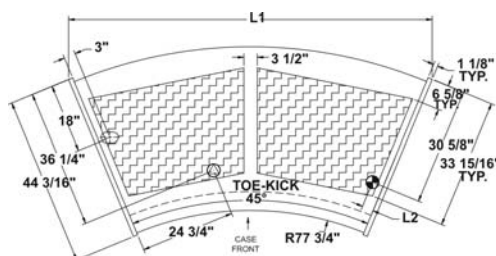

Plan View - FLPCC67

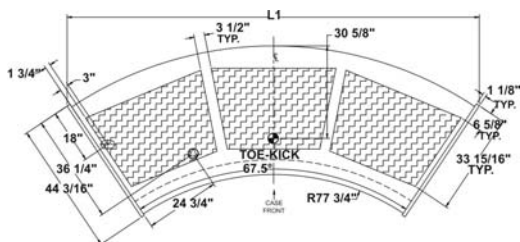

INFORMATION IS SUBJECT TO CHANGE WITHOUT NOTICE.



For more information on any of our products or services please visit us on the web at:
www.structuralconcepts.com