

Wave Series - WDCX Convex Upright Door Cases

Models

F2CX
F3CX



Applications

- Forced air refrigeration
- Medium temperature integrated average of 41°F
- For fresh floral arrangements
- Designed to be used with straight and curved merchandisers to create WAVE lineups

Convex curved upright door merchandisers for floral products

Standard Features

- Black interior
- Black exterior
- No end panels (specify ends per lineup)
- Curved frameless glass clear view doors
- Galvanized exterior back panel
- Non-lighted clear glass shelves
- T-8 top light
- Electrical leads
- Top electrical access
- Base rail system for shims
- Remote refrigeration with TXV piped at base
- ETL conforms to UL 471

Options

- Laminate exterior
- Full, cutaway, case to case or filler end panels
- Black exterior back panel
- 2" bumper on ends
- Remote refrigeration with TXV piped at top

ONE PART PASSION, TWO PARTS SCIENCE



Specifications - WDCX Convex Upright

Model	LxDxH
F2CX	63-1/8"x45-1/16"x85-13/16"
F3CX	90-5/8"x45-1/16"x85-13/16"

Plan View - F2CX

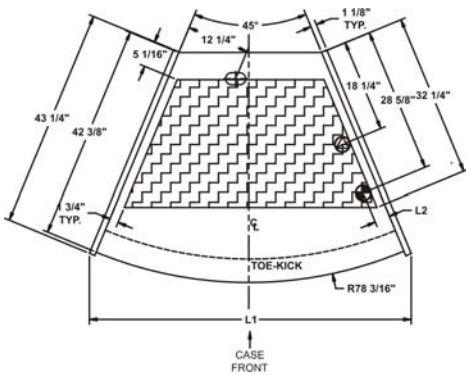

Plan View - F3CX

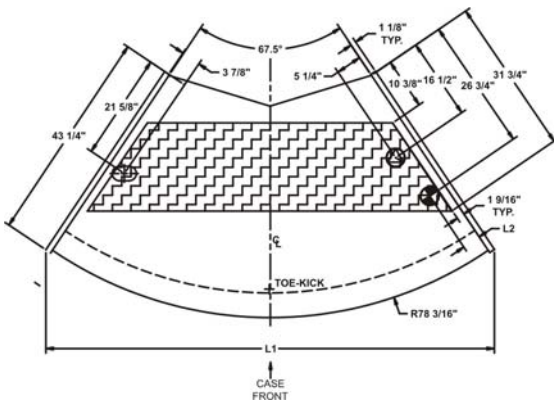

STANDARD

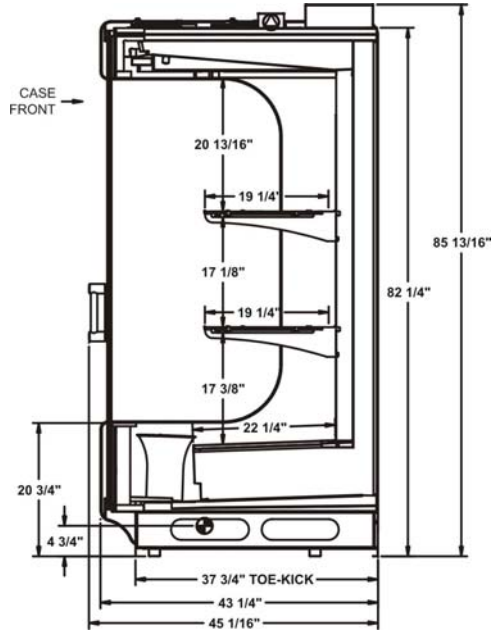

IMPORTANT NOTES

INTENDED ENVIRONMENT

Designed to operate in ambient conditions of 75°F with 55% relative humidity.

INTENDED USE

Refrigerated floral products

INFORMATION IS SUBJECT TO CHANGE WITHOUT NOTICE.

