

CO Series - WN Service Refrigerated Wine Cases

Models
B42WN



Refrigerated service case for wine.

Applications

- Forced air refrigeration
- Medium temperature integrated average 55°F
- Multiple shelves
- For refrigerated wine

Standard Features

- Black interior
- Painted exterior
- Full end panels
- Locking front doors
- Galvanized solid rear back panel
- Non-lighted horizontal bottle support w/ angled front display
- T-8 side light
- Electrical leads
- Levelers
- Remote refrigeration with TXV
- ETL certified to CAN/CSA 22.2, conforms to UL 471 & NSF 7

Options

- White or stainless steel interior
- Stainless steel exterior
- Oak Veneer exterior
- Black or white solid back panel
- Lighted shelves (specify T-8 or LED)
- Casters
- Breeze™ self-contained refrigeration with 6' power cord

ONE PART PASSION, TWO PARTS SCIENCE



Specifications - WN Cases

Standard

TOP OF HEADER AREA
MUST NOT BE OBSTRUCTED
IF POSITIONED IN AN ALCOVE.
MINIMUM 2" CLEARANCE
REQUIRED.

CONDENSER AIR
DISCHARGE -
DO NOT BLOCK
ENTIRE LENGTH
OF CASE

CASE
FRONT

Model	LxDxH
B42WN	44-15/16"x26-1/8"x79-3/4"

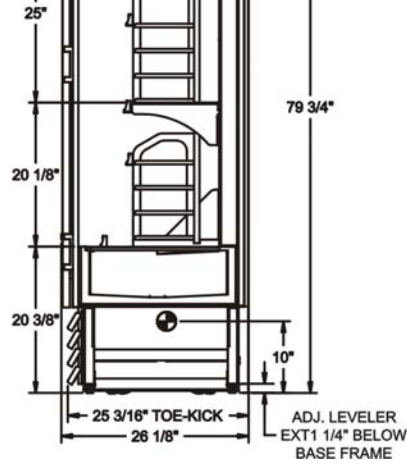

IMPORTANT NOTES

Units are supplied with levelers which must be adjusted during installation to ensure the unit is level and plumb.

Dimensions reflect levelers extended 1-1/4".

INTENDED ENVIRONMENT

Designed to operate in ambient conditions of 75°F with 55% relative humidity.

Integrated average product temperature of 55°F.

INTENDED USE

Packaged refrigerated products.

INFORMATION IS SUBJECT TO CHANGE WITHOUT NOTICE.

