

# WAVE Series - WO Straight Open Upright Cases



## Models

FR3  
FR4  
FR5  
FR6  
FR8  
FR10

## Applications

- Forced air refrigeration
- Medium temperature integrated average 41°F
- For fresh cut flowers
- Designed to be used with straight and curved merchandisers to create WAVE lineups

## Straight open upright merchandisers for floral products

### Standard Features

- Black interior
- Black exterior
- No end panels (specify ends per lineup)
- Open reach-in front
- Galvanized exterior back panel
- 13" bucket support shelves (4 levels)
- T-8 top light
- Glass upper & lower front panels
- Electrical leads
- Top electrical access
- Base rail system for shims
- Remote refrigeration with TXV piped at base
- ETL conforms to UL 471

### Options

- Laminate exterior
- Full or cutaway end panels
- Black exterior back panel
- 2" bumper on ends
- Remote refrigeration with TXV piped at top
- Fresh Flow® automatic watering system

ONE PART PASSION, TWO PARTS SCIENCE



# Specifications - WO Straight Open Upright

Model	LxDxH
FR3	32-1/2"x43-1/4"x85-13/16"
FR4	50-1/4"x43-1/4"x85-13/16"
FR5	62-7/8"x43-1/4"x85-13/16"
FR6	74-1/4"x43-1/4"x85-13/16"
FR8	93-1/8"x43-1/4"x85-13/16"
FR10	123-3/8"x43-1/4"x85-13/16"

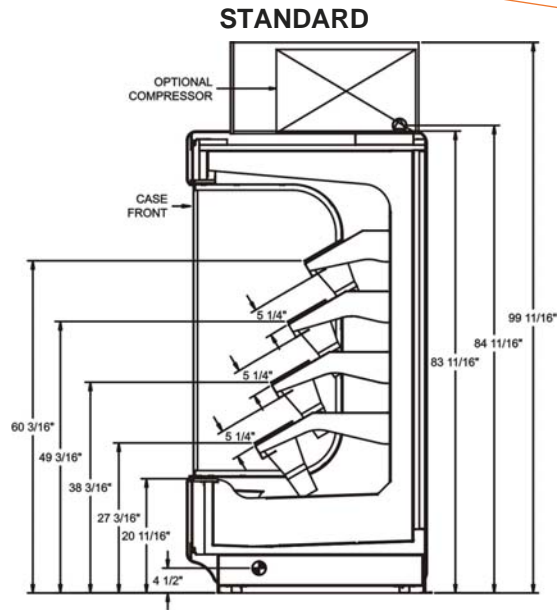

## IMPORTANT NOTES

### INTENDED ENVIRONMENT

Designed to operate in ambient conditions of 75°F with 55% relative humidity.

### INTENDED USE

Refrigerated floral products

Bucket Capacities			
Model	Standard Configuration		W/ Optional Fresh Flow System
FR3	Shelving = (12) 8"D x 13"T	Deck = (3) 9"D x 10"T	Fresh Flow = (12) 8"D x 13"T Deck = (3) 9"D x 10"T
FR4	Shelving = (24) 8"D x 13"T	Deck = (4) 9"D x 10"T	Fresh Flow = (24) 8"D x 13"T Deck = (4) 9"D x 10"T
FR5	Shelving = (28) 8"D x 13"T	Deck = (6) 9"D x 10"T	Fresh Flow = (28) 8"D x 13"T Deck = (6) 9"D x 10"T
FR6	Shelving = (36) 8"D x 13"T	Deck = (8) 9"D x 10"T	Fresh Flow = (36) 8"D x 13"T Deck = (8) 9"D x 10"T
FR8	Shelving = (44) 8"D x 13"T	Deck = (10) 9"D x 10"T	Fresh Flow = (44) 8"D x 13"T Deck = (10) 9"D x 10"T
FR10	Shelving = (60) 8"D x 13"T	Deck = (13) 9"D x 10"T	Fresh Flow = (60) 8"D x 13"T Deck = (13) 9"D x 10"T

INFORMATION IS SUBJECT TO CHANGE WITHOUT NOTICE.

