

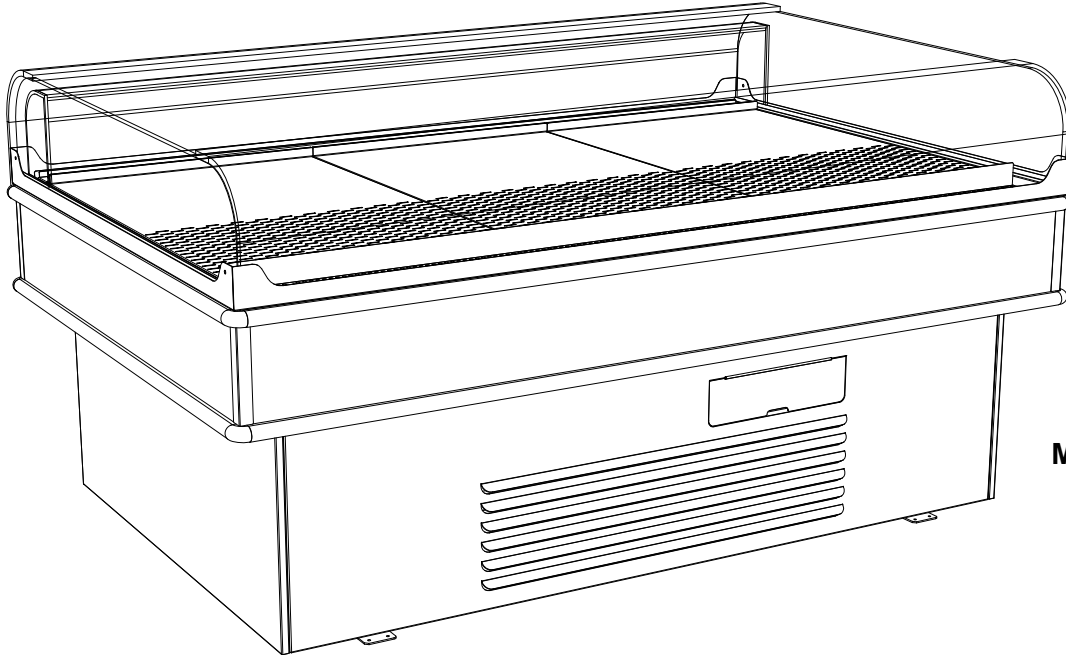

INSTALLATION & OPERATING MANUAL

PN 54423

SELF-SERVICE MULTI-PURPOSE REFRIGERATED ISLAND DISPLAY CASE



Model MI6R

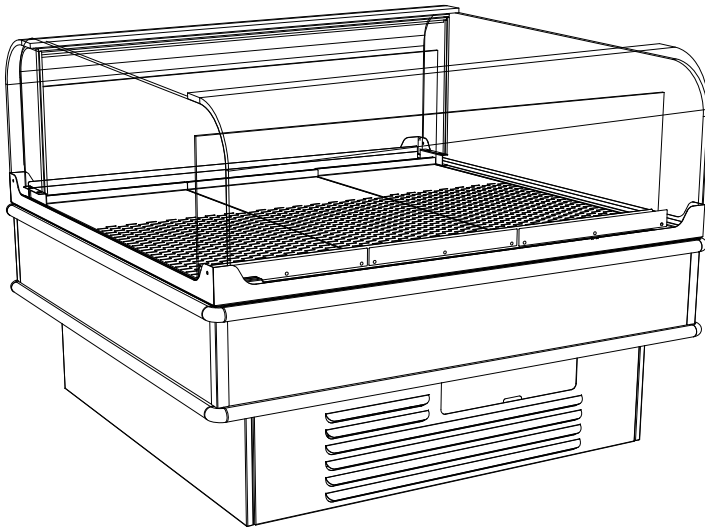

Model MI4R.4763

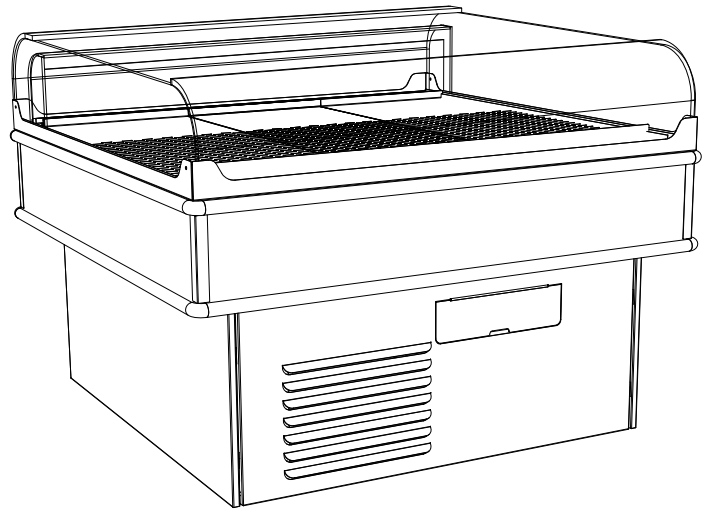

Model MI4R

Model MI4R.....	49 1/2" L x 48 1/4" D x 37" H
Model MI4R.4763 / MI4R.5132	49 1/2" L x 48 1/4" D x 37" H
Model MI5R.....	61 3/4" L x 48 1/4" D x 37" H
Model MI6R.....	74 3/4" L x 48 1/4" D x 37" H



Structural

Concepts

888 E. Porter Road · Muskegon, MI 49441 Phone: 231.798.8888 Fax: 231.798.4960 www.structuralconcepts.com

TABLE OF CONTENTS

OVERVIEW AND WARNINGS	3
SHIPMENT CONDITION / DAMAGE DISCOVERED DURING DELIVERY or UNCRATING / SHORTAGES	4
CASE REMOVAL FROM SKID (CASTERS, LEVELERS OR FRAME SUPPORT RAILS)	5
POSITIONING-LEVELING UNIT / START-UP / TEMPERATURE CONTROL ACCESS / 41° & 38°SWITCH	6
ACRYLIC AIRFLOW PIECE SETUP - PAGE 1 of 2	7
ACRYLIC AIRFLOW PIECE SETUP - PAGE 2 of 2	8
VERIFICATION THAT UNIT IS RUNNING PROPERLY	9
LOAD LIMIT (LOAD LINE) GUIDELINES / CASE FRONT & REAR DESIGNATIONS	10
REFRIGERATION FUNDAMENTALS	11
REFRIGERATION SLIDE-OUT EXPLODED PICTORIAL	12
SERIAL LABEL LOCATION & INFORMATION LISTED / TECH INFO & SERVICE.....	13
CLEANING SECHEDULE	14
TROUBLESHOOTING	15-16
TROUBLESHOOTING - CONDENSING SYSTEM (QUALIFIED SERVICE TECHNICIANS)..	17
TROUBLESHOOTING - EVAPORATOR SYSTEM (QUALIFIED SERVICE TECHNICIANS)..	18
PREVENTIVE MAINTENANCE (PERFORMED BY TRAINED SERVICE PROVIDER)	19
CAREL CONTROLLER: Programming The Instrument	20
CAREL CONTROLLER: User Interface - Display / Summary Table of Alarm and Signals: Display, Buzzer and Relay	21
CAREL CONTROLLER: Summary Table of Operating Parameters	22
CAREL CONTROLLER: Changing “Red Meat” and “Produce” Setpoints Using The Thermostat Controller	23
TECHNICAL SERVICE CONTACT INFORMATION & WARRANTY INFORMATION	24

OVERVIEW AND WARNINGS

OVERVIEW

- The Structural Concepts self-service cases are designed to merchandise packaged products at 41°F or less product temperatures.
- These cases should be installed and operated according to this operating manual's instructions to insure proper performance. Improper use will void warranty.

This unit is designed for the display of products in ambient store conditions where temperatures and humidity are maintained within a specific range.

- For NSF® Type 1 Conditions (most cases): ambient conditions are to be at 55% max. humidity / 75°F.

Caution: Do not allow air conditioning, electric fans, open doors or windows to create air currents around display case as this may detrimentally affect proper case temperatures and operation.



ATTENTION INSTALLER
This equipment must be installed in compliance with all applicable NEC, federal, state and local plumbing codes.



WARNING
Risk of Electric Shock.
Disconnect Power Before Servicing Unit



WARNING
Hazardous Moving Parts.
Do Not Operate unit with covers removed.
Fan blades may be exposed when deck panel is removed.
Disconnect power before removing deck panel.



WARNING
Evaporator Tray is Hot

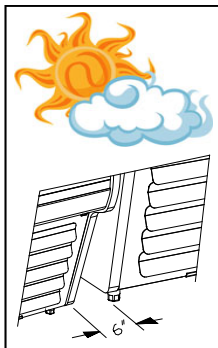

WARNING! ADVERSE CONDITIONS / SPACING ISSUES

- Performance issues caused by adverse conditions are NOT covered by warranty.
- Unit must be kept at least 15-feet from exterior doors, overhead HVAC vents or any air curtain disruption to maintain proper temperatures.
- Unit must not be exposed to direct sunlight or any heat source (ovens, fryers, etc.).
- Tile floors, low ceilings or small rooms will increase noise level. Whisper Cool compressor blanket or remote unit may resolve noise level issues.

1. Shipment Condition

- Before and during unloading check all equipment for damage.

2. Damage Discovered During Delivery

- 3rd Party Carrier: Describe damage on freight bill and obtain signature of driver. Carrier will supply necessary claim forms. If these steps are not taken, carrier may refuse your claim.
- Prepaid and Add: Contact carrier (and follow same procedure as with 3rd party carrier). Also contact Structural Concepts at 1-800-433-9489.

3. Damage Discovered After Uncrating

- 3rd Party Carrier: Contact carrier within 10 days of delivery for their procures; retain all packaging. If these steps are not taken, carrier may refuse your claim.
- Prepaid and Add: Contact carrier (and follow same procedure as with 3rd party carrier). Also contact Structural Concepts at 1-800-433-9489 within 10 days of delivery.

4. Shortages

- If a shortage exists (and it is the responsibility of Structural Concepts) call 1-800-433-9489. Structural Concepts will acknowledge shortages within 10 days from receipt of equipment.
- If a shortage involves the carrier, notify carrier immediately and request an inspection.

CASE REMOVAL FROM SKID (CASTERS, LEVELERS OR FRAME SUPPORT RAILS)

1. Removing Case Shipping Brackets That Are Attached To Skid

- Remove screws holding Case Shipping Brackets to skid.
- Remove Case Shipping Brackets from Skid.
- See illustrations below. Note: Shipping Brackets will vary in size, shape, material and location depending upon case type and model.

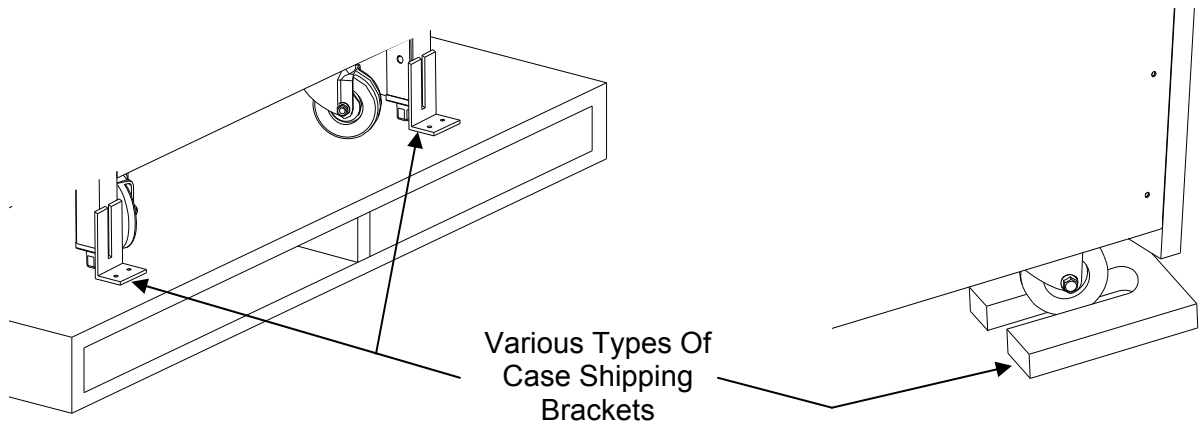

2. Remove Case (With Casters) From Skid

- Place ramp up against skid (to allow case to smoothly slide off from skid).
 - Maintain support of case at all times or center of gravity may cause case to fall.
 - Unlock Casters. Slide unit to rear of skid. Slide down ramp and off from skid.
- Note: Illustrations reflect general outline of sample case and may not reflect your particular model or options).

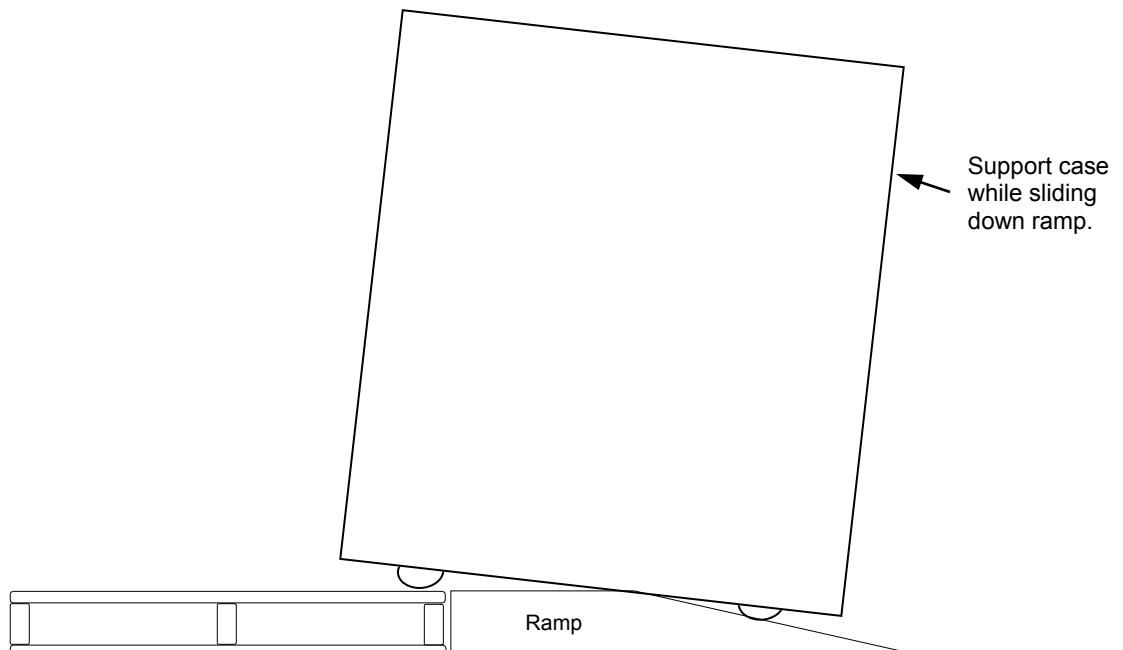

Position and Level Unit

- Position Unit. Remove either controls side or opposite side grille to access levelers (see below). Grilles may be simply lifted up and off.
- Level unit by either hand-cranking or using adjustable wrench (see below). Return grilles.

Dipslay Case Start-Up

- Lift up controls cover on control side of unit (see illustrations below).
- Turn on main power switch.
- Main power switch will start evaporator coil fans, and the compressor motor.

Temperature Control Access

- Lift up controls cover on control side of unit.

- See the temperature controller section of this manual for instructions and details on proper temperature controller settings.

41° / 38° Temperature Control Switch

- “O” (Open Position Switch Setting): Controller maintains the preset value for “Red Meat”.
- “I” (Closed Position Switch Setting): Controller modifies the set point, adding the value of the parameter (r4). For example, when ‘r4’ = 3° (as a preset value), switching to “I” (closed position) will INCREASE the setpoint by 3.0°F for “Produce”.
- To raise or lower temperature setpoints BEYOND the preset values, see **CAREL CONTROLLER: Changing “Red Meat” and “Produce” Setpoints Using The Thermostat Controller** section in manual.

Note: Illustrations on this sheet may not exactly reflect every feature or layout of your particular model.

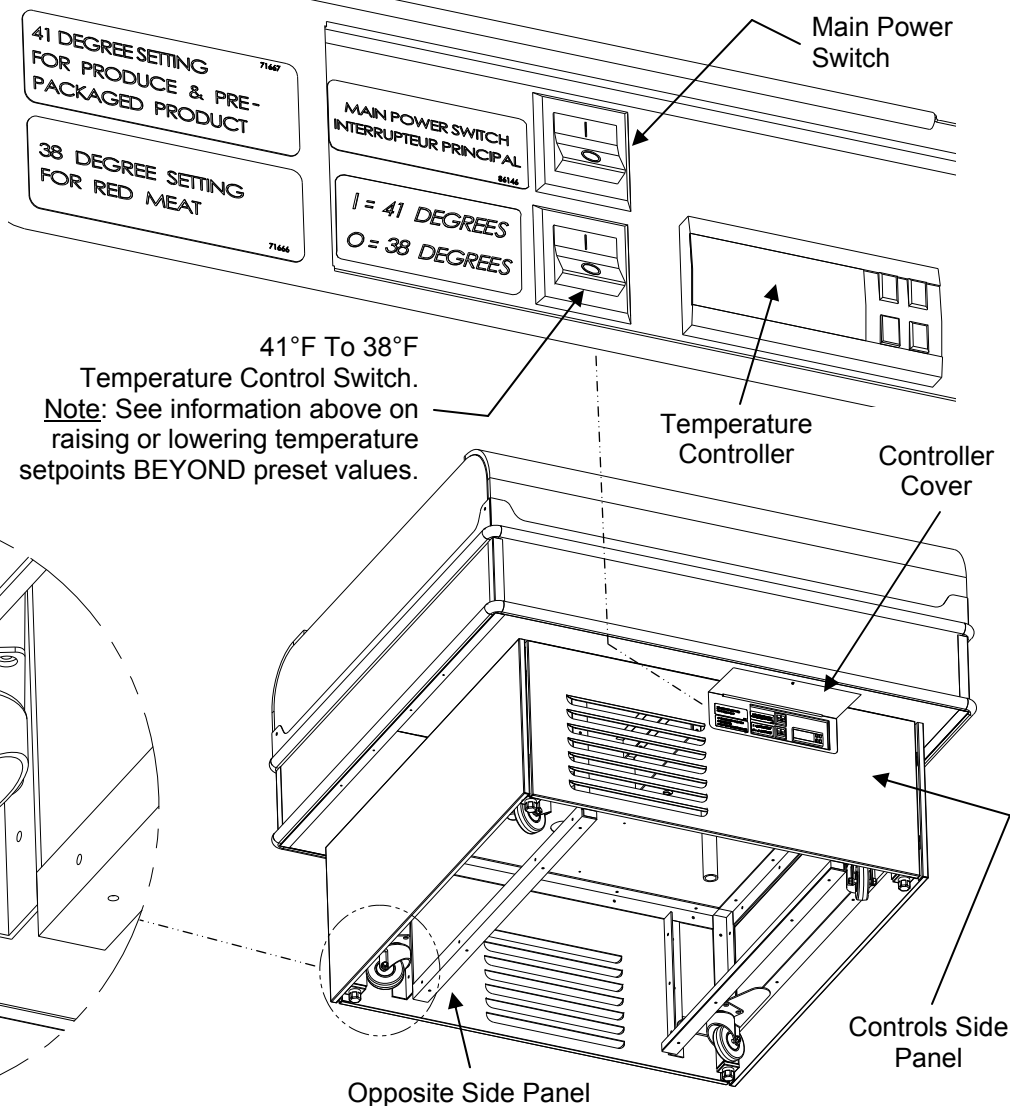

Adjustable Wrench

41°F To 38°F Temperature Control Switch.
Note: See information above on raising or lowering temperature setpoints BEYOND preset values.

Acrylic Airflow Piece Setup

Due to unique airflow needs, multiple acrylic pieces are to be carefully placed at specific places on the case.

- Illustrations below reflects this layout.
- **Caution! Improper acrylic airflow piece setup can result in fogging or improper temperature variance.**
- Make certain that the inner and outer curved airflow pieces BOTH are inserted in the appropriate bracket (as illustrated).
- Make certain that the flat air shield is inserted in the flat air shield bracket (as illustrated).
- See next page for exploded pictorial of acrylic airflow pieces.

Enlarged View With Outer Acrylic Retainer Intact

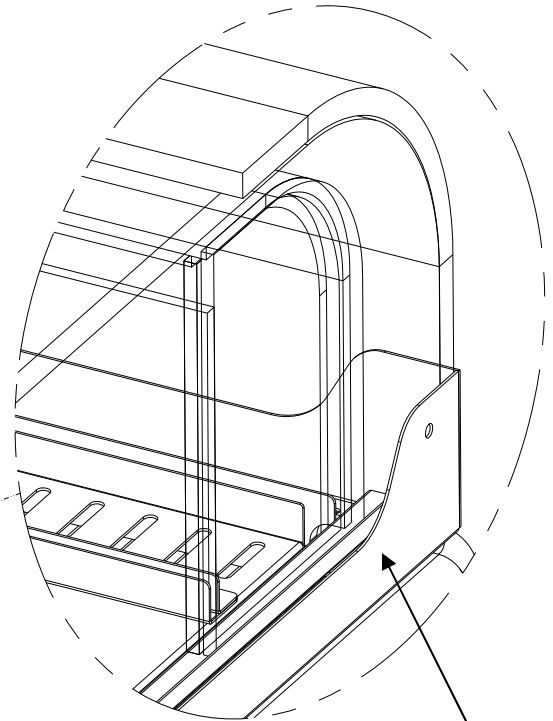
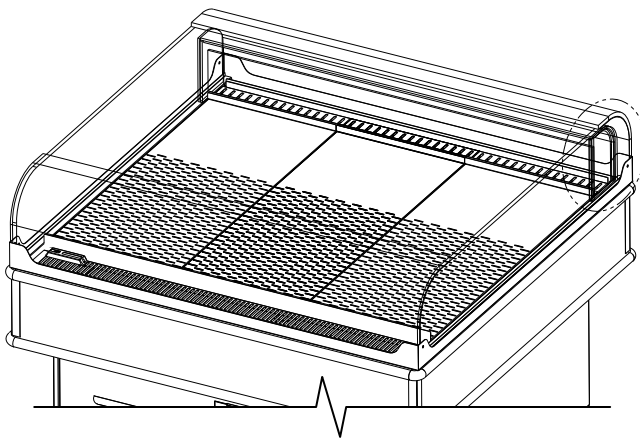

Outer Acrylic Retainer

Inner Air Flow Piece End Caps

Inner Air Flow Pieces

Inner Curved Airflow Piece

Outer Curved Airflow Piece

Inner Air Flow Piece Brackets

Flat Air Shield

Flat Air Shield Bracket

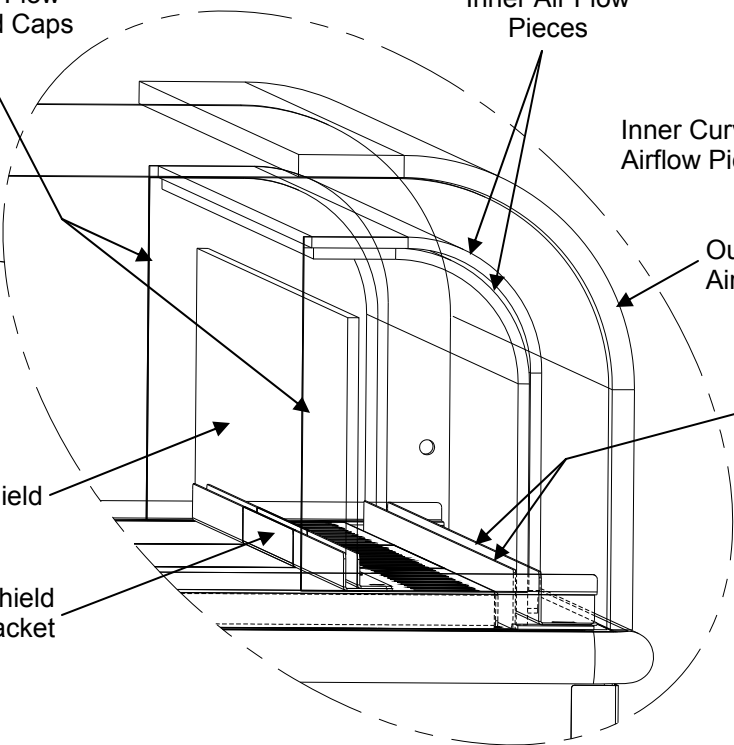
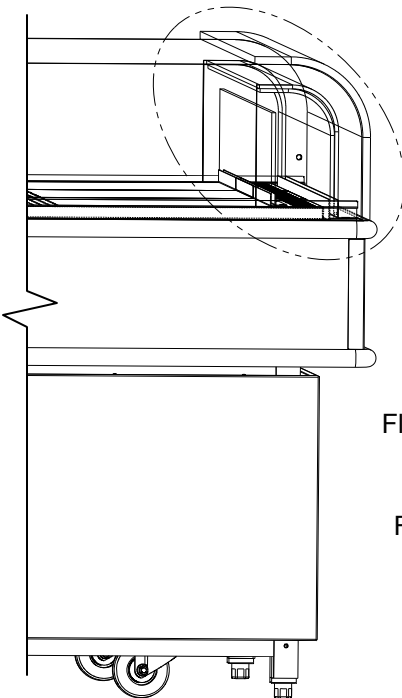

View With Outer Acrylic Retainer Removed

Acrylic Airflow Piece Setup

Due to unique airflow needs, multiple acrylic pieces are to be carefully placed at specific places on the case.

- Illustrations below reflects an exploded pictorial of this layout and their specific identification markings.
- **Caution! Improper acrylic airflow piece setup can result in fogging or improper temperature variance.**

Note: Product stop on return air side (shown below) is found on Model MI4R.4763 only.

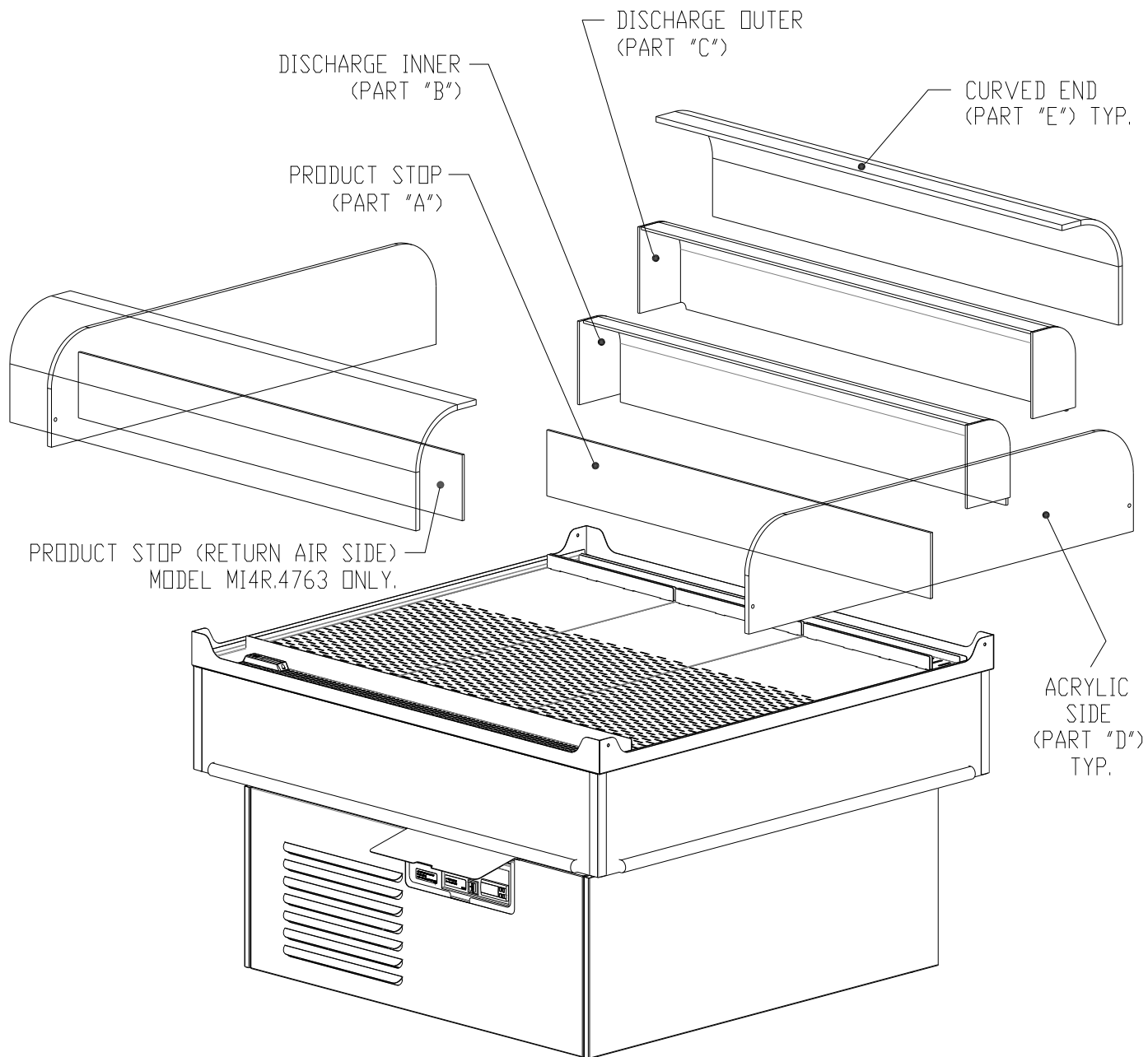

VERIFICATION THAT UNIT IS RUNNING PROPERLY

Verification That Unit is Running Properly

After power has been supplied, evaporator coil fans and compressor motor will be operational.

- To verify fans are operational, lift up deck pans; check to see that the evaporator coil fan is functioning properly.
- Illustration below shows display case with decking (and sub-decking) removed.

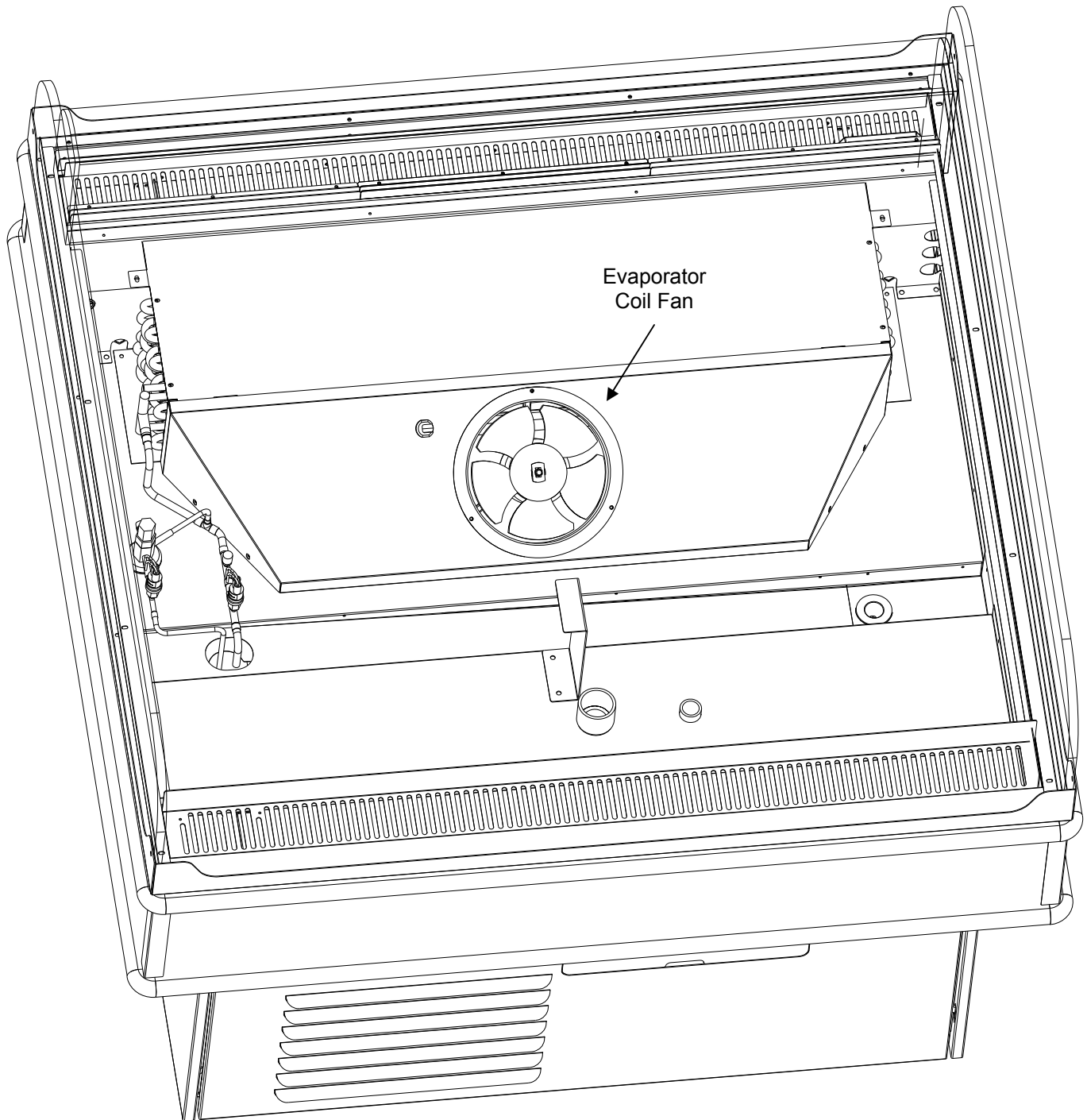

LOAD LIMIT (LOAD LINE) GUIDELINES / CASE FRONT & REAR DESIGNATIONS

Load Limit (Load Line) Guidelines

Caution! Stacking food beyond the load line will prevent food from being at proper temperature.

- Load line is placed at location to allow proper refrigerated airflow to product.
- Load line will be etched in acrylic on both sides of case.
- See illustration below for load line locations.

Case Front & Rear Designations

- Case front is the controls side of case (see illustration below). This is also the air intake side of case.
- Case rear is the air discharge side of case (see illustration below). This is the side of case that the refrigeration package is slid out for cleaning and/or servicing.

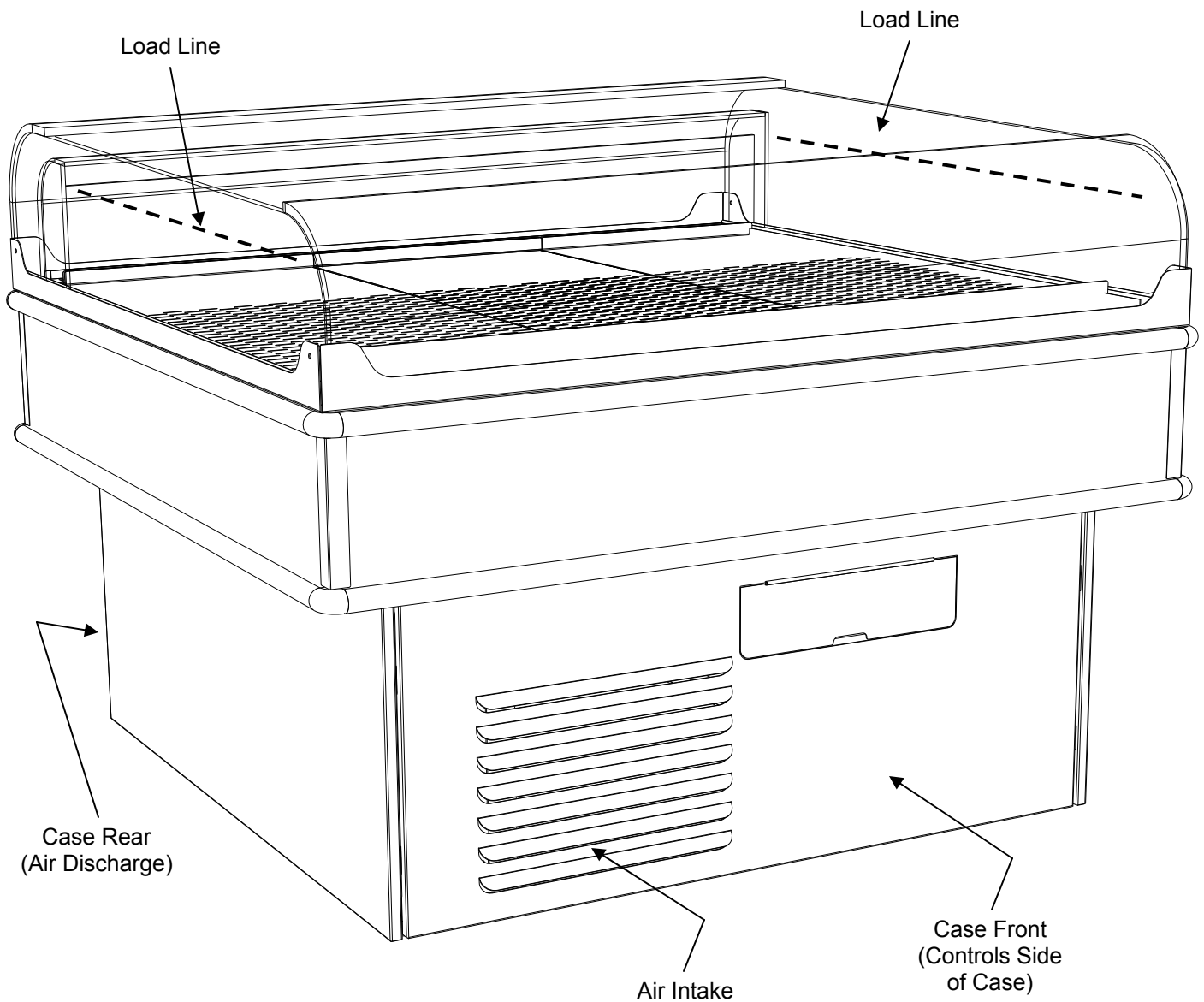

Refrigeration Package Access

Note: Servicing to be accomplished by licensed electrical / refrigeration contractor.

Pull Out Refrigeration Package

- Slide grille (located opposite to temperature controls) up and out. No tools are required.
- Note: At initial slide-out, it may be necessary to remove compressor pan shipment screws (see illustration at right for location).
- Refrigerant lines are flexible to facilitate rear access maintenance.
- Plastic glides are mounted at base to assist in sliding the condenser out for access.
- Slide condenser unit out 12 to 18 inches to access high pressure service connection.

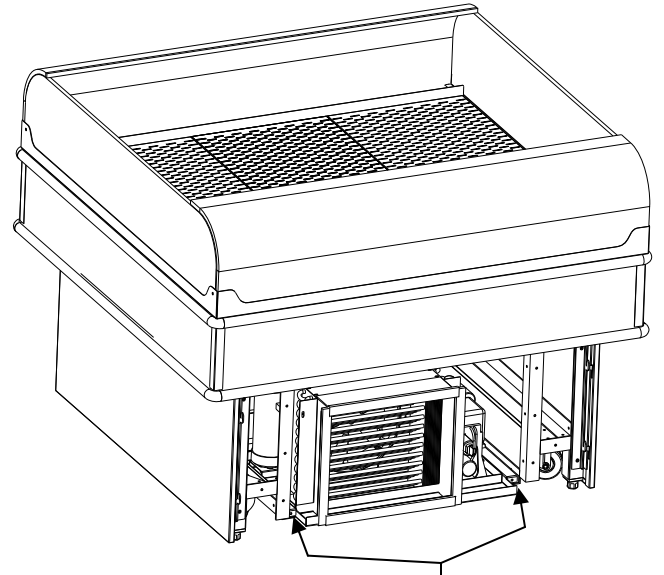

Compressor Pan Shipment Screw (one at each side)

Temperature Controller (Self-Contained Units Only)

- Temperature Controller is located behind the temperature controls cover. See illustration at mid-right and lower-right.
- Temperature / Defrost control settings are programmable from this location.
- Case Temperature Set Point is set at the factory, as determined by case size & sensor probe location.
- Temperature is controlled by thermostat.
- If a temperature setting change is required, follow instructions regarding Temperature Control Programming Steps in the technical information section of this operating manual.
- If service is required to the temperature control unit, call Structural Concepts Corporation. Maintenance should be performed by a certified technician.
- The toll-free number is listed in the Technical Service section of this manual.
- See Temperature Controller section in this manual.

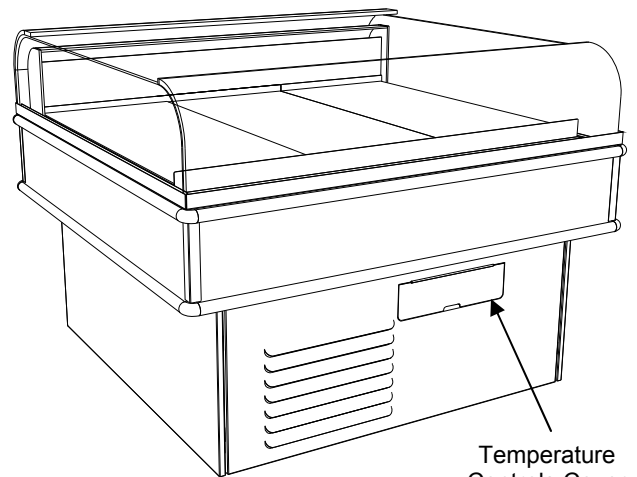

Temperature Controls Cover

NOTE: Spirit-filled thermometers located in the refrigerated compartment are for monitoring warmest air temperature in accordance with NSF Std. 7

Evaporator Pan Access / Removal

- See illustration at lower-right.
- Turn off main power; allow evaporator pan to cool.
- Evaporator Pan access and removal may be performed at controls side (no tools required).
- **WARNING! Evaporator Pan May Be Hot!** Check temperature of pan prior to handling.
- Remove evaporator pan box.
- Unplug evaporator pan from the electric outlet.
- Empty evaporator pan contents into container.
- Replace grille when completed.

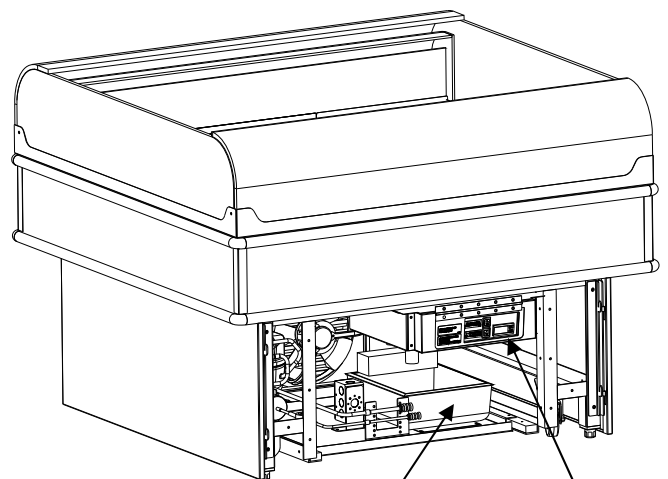

Evaporator Pan Temperature Controller

REFRIGERATION SLIDE-OUT EXPLODED PICTORIAL

The following images show the various parts pertaining to the Refrigeration Unit (that is slid directly out from under display case) to be serviced.

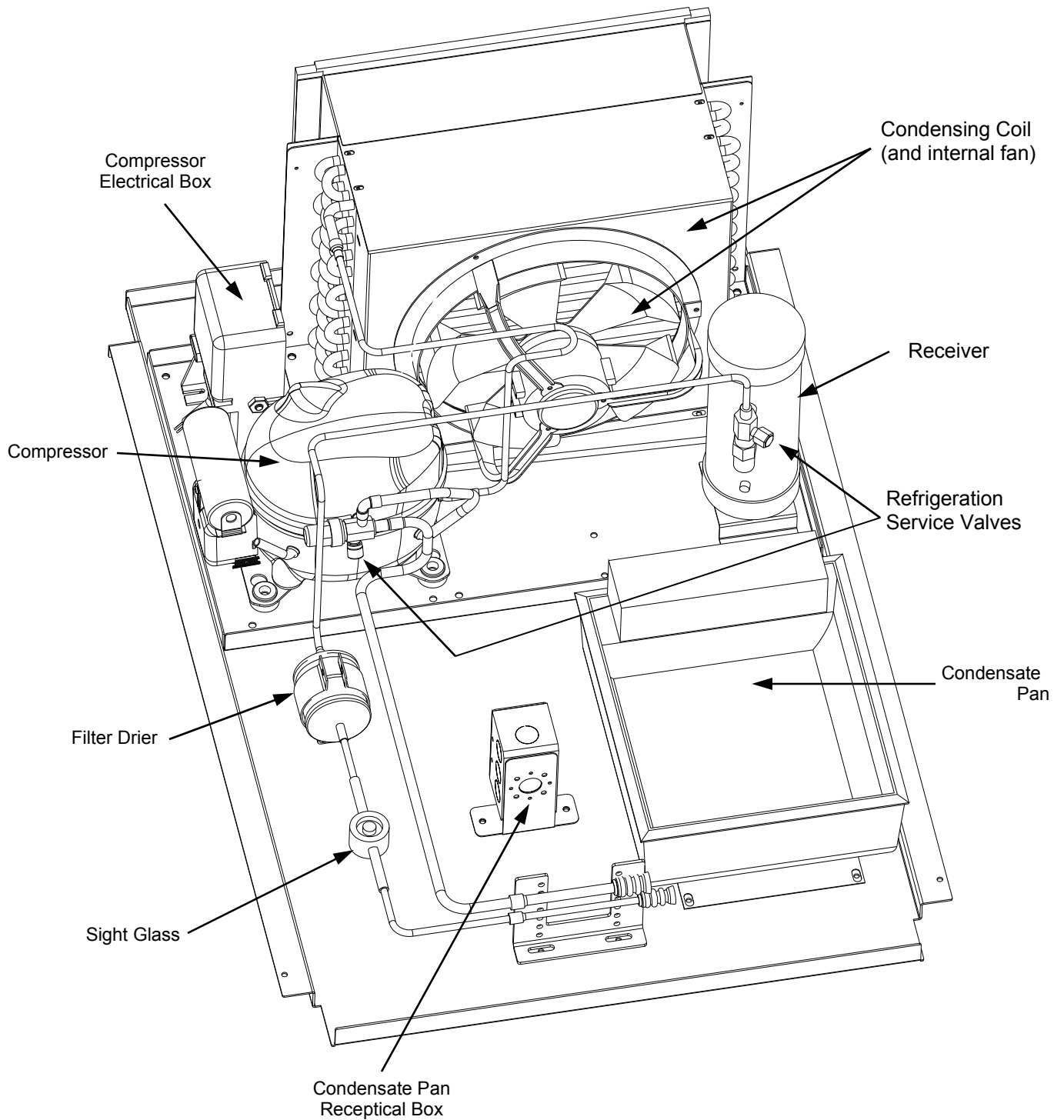

Serial Label Location & Information Listed / Technical Information & Service

- Serial labels are located near the electrical access on your case.
- Serial labels contain electrical, temperature & refrigeration information, as well as regulatory standards to which the case conforms.
- For additional technical information and service, see the *TECHNICAL SERVICE* page in this manual for instructions on contacting Structural Concepts' Technical Service Department.
- See images below for samples of both refrigerated and non-refrigerated serial labels.

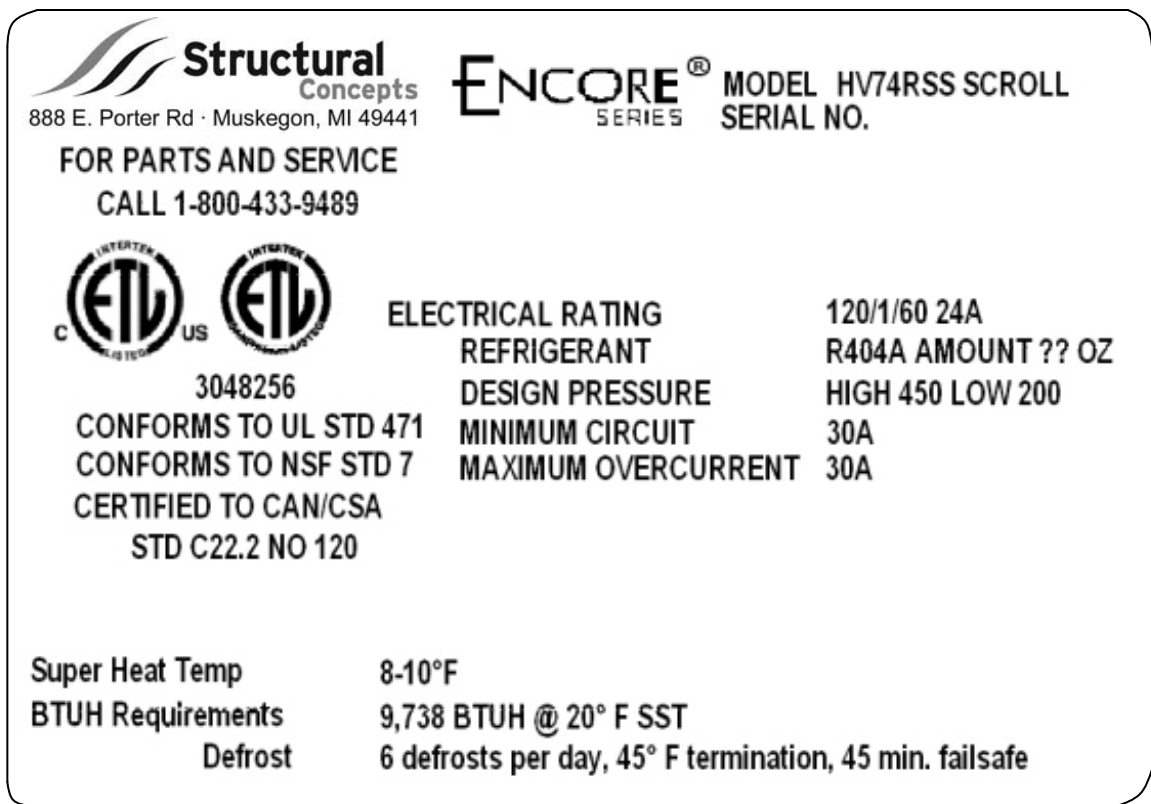

Structural Concepts
888 E. Porter Rd · Muskegon, MI 49441

ENCORE[®] SERIES MODEL HV74RSS SCROLL SERIAL NO.

FOR PARTS AND SERVICE
CALL 1-800-433-9489

ETL 3048256
CONFORMS TO UL STD 471
CONFORMS TO NSF STD 7
CERTIFIED TO CAN/CSA STD C22.2 NO 120

ELECTRICAL RATING	120/1/60 24A
REFRIGERANT	R404A AMOUNT ?? OZ
DESIGN PRESSURE	HIGH 450 LOW 200
MINIMUM CIRCUIT	30A
MAXIMUM OVERCURRENT	30A

Super Heat Temp	8-10°F
BTUH Requirements	9,738 BTUH @ 20° F SST
Defrost	6 defrosts per day, 45° F termination, 45 min. failsafe

----- Sample Serial Label For Refrigerated Case -----

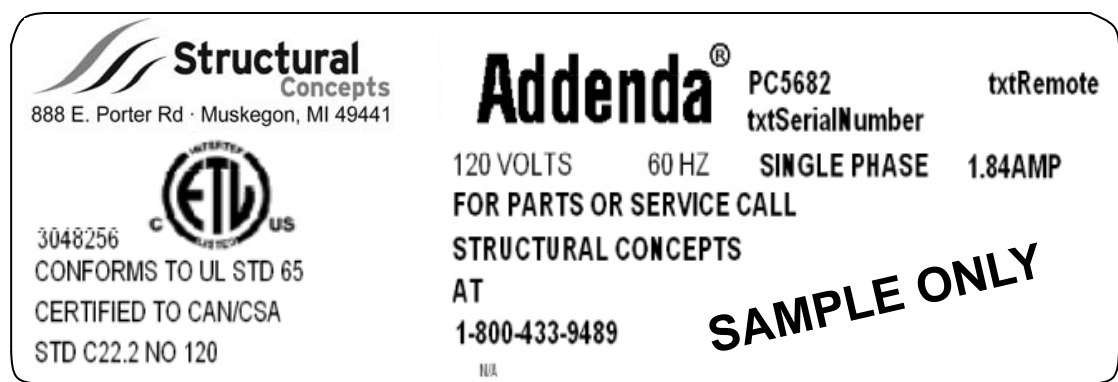

Structural Concepts
888 E. Porter Rd · Muskegon, MI 49441

Addenda[®] PC5682 txtRemote
txtSerialNumber

120 VOLTS 60 HZ SINGLE PHASE 1.84AMP

FOR PARTS OR SERVICE CALL
STRUCTURAL CONCEPTS
AT
1-800-433-9489

SAMPLE ONLY

ETL 3048256
CONFORMS TO UL STD 65
CERTIFIED TO CAN/CSA STD C22.2 NO 120

----- Sample Serial Label For Non-Refrigerated Case -----

CLEANING SCHEDULE (“D” = Daily / “W” = Weekly / “M” = Monthly)

Cleaning	D	W	M	Task
Clean Acrylic	X			<p>Acrylic MUST BE cleaned according to these instructions to prevent acrylic surfaces from becoming cloudy, dull or scratched.</p> <ul style="list-style-type: none"> DO NOT use a dry cloth or paper towel to wipe off dust or debris (this can rub dirt and dust into the acrylic surface). BEFORE cleaning, use air pressure or feather duster to blow or remove all dust and debris. DO NOT use household cleaners (such as ammonia, bleach, Windex® or Formula 409®). DO NOT use powder scouring cleansers (such as Comet® or Ajax®) or other abrasive cleansers on acrylic! DO use a soft sponge or cloth with a mix of warm (not hot!) water and mild soap solution (such as Palmolive®, Joy®, Dawn®, or Ajax® dishwashing detergents) to wipe down surfaces. DO use acrylic cleaning product such as Brillianize®, or Novus® #1 (if you want to purchase cleaners specifically formulated to clean acrylic). DO rinse out the soft sponge or cloth often in the solution while cleaning the acrylic. This keeps the dust and debris from being collected in one area and relocated to another! DO wipe dry with a microfiber cloth, microfiber terry cloth or chamois cloth to dry acrylic surfaces. DO NOT wipe dry with a dry cloth or paper towel! DO use products such as Novus® #2 to remove fine scratches, haziness and abrasions that can form in acrylic. Also, Pittman ALR® may be used to removed oxidation (cloudy or dull acrylic surfaces).
Clean Case Interior	X			Shelves and decks can be cleaned with a warm soap and water solution.
		X		Remove the decks and clean with soap and water.
		X		Vacuum tub under deck. Clean with soap and water. Wipe dry with clean cloth.
		X		Keep drains clean and free of debris which could clog the drain and rob the case of needed refrigeration.
Clean Condensing Coil		X		Clean the condenser coil.
			X	Using air pressure if available, or an industrial strength vacuum, clean the dust and dirt that collects on the condenser coil. (Be careful not to damage the fins on the coil.)

TROUBLESHOOTING - GENERAL ISSUES

CONDITION	TROUBLESHOOTING
Water Is On The Floor	Check that the drain trap is free of debris.
	Check that the drain hose is correctly positioned over evaporator pan (or floor drain, for remote units).
	Check store conditions. To prevent condensation in NSF® Type 1 environments, maximum conditions are to be 55% humidity / 75° Fahrenheit. For NSF® Type 2, maximum conditions are to be 60% humidity / 80° Fahrenheit. See serial label (at case rear near main power switch) for NSF® Type of your case.
	Check evaporator pan float for proper operation.
	Check that evaporator pan is plugged in.
	EVAPORATOR PAN MAY BE MALFUNCTIONING. If so, water will overflow pan and seep onto flooring causing damage! Until evaporator pan is functioning (or is replaced), the following procedures are recommended: <ul style="list-style-type: none"> • Use wet-dry vacuum (or mop & bucket) to remove standing water. • Use 'catch pans' for water to drain into. Swap out regularly until case has completely drained.
	DISRUPTION OF POWER CAN CAUSE WATER TO OVERFLOW PAN AND SEEP ONTO FLOORING CAUSING DAMAGE! Check that power to case is constant. Until power is restored, following these procedures: <ul style="list-style-type: none"> • Use wet-dry vacuum (or mop & bucket) to remove standing water. • Use 'catch pans' for water to drain into. Swap out regularly until evaporation of case is complete (or until power is restored). • When power to case is restored, evaporator pan should function properly and water will no longer overflow onto flooring.
Fan Emits Excessive Noise	Check that the case is aligned, level and plumb.
	Check evaporator fan for cleanliness.
	Unplug fan motor; check motor shaft for excessive bearing wear.
	Check that fan motor is securely mounted in brackets.
	Verify that fan blade is securely mounted to fan motor.
	Check that nothing is preventing blade rotation.
Check that the fan shroud is properly secured.	
Fans Are Not Working	Check that the MAIN power switch (if present) is on.
	Check that fans are plugged in to fan shroud.
	Check for foreign material obstructing fan performance.
	Check that fan blade freely rotates within fan shroud.

TROUBLESHOOTING - GENERAL ISSUES, CONTINUED

CONDITION	TROUBLESHOOTING
Fan Is Not Working, Continued	Check that power is going to fan
	Check that fan wiring is connected on terminal blocks.
System Is Not Operating	Check that the utility power is on.
	Check the circuit breaker box for tripped circuits.
Case Is Not Holding Temperature	If a large amount of warm product was added to the case, it will take time for the temperature to adjust. Product should be pre-chilled before placing in display case.
	Check Temperature Controller section in this manual.
	Check that the case is not in the sun or near a heat or air conditioning vent.
	If case is located near outside doors, temperature fluctuation can hinder unit's ability to maintain temperature.
	Check air grilles for obstructions. Maintain airflow clearance of 6" (minimum) to 12" (recommended) at case front and rear.
	Check sight glass for flashing and/or low charge.
	Check Set Point Temperature; it may be adjusted too high.
Control Display Is Flashing	Check Temperature Controller section in this manual.
Condensing Unit Is Not Operating (Self-Contained Units Only)	Check Temperature Controller section in this manual.
	Check that the power is turned on.
	Review Temperature Controller's Settings for accuracy.

TROUBLESHOOTING - CONDENSING SYSTEM (QUALIFIED SERVICE TECHNICIANS ONLY)

CONDITION	TROUBLESHOOTING
Head Pressure Too High	Check that the Condensing Coil is not dirty or covered.
	Check that Condensing Fans are working.
	Check that the refrigeration system is not overcharged.
	Check that case is free of non-condensibles.
	Check that Liquid Line Drier Filter is not plugged.
	Check Set Point temperature; it may be adjusted too high.
	Check System Operating temperatures.
	Check that Store Ambient temperature isn't above maximum allowed. See <i>Overview and Warnings</i> Section.
Head Pressure Too Low	Check that Refrigerant Charge isn't too low.
	Check that Suction Pressure isn't too low.
	Check to verify that Compressor Valves aren't faulty.

TROUBLESHOOTING - EVAPORATOR SYSTEM (QUALIFIED SERVICE TECHNICIANS ONLY)

CONDITION	TROUBLESHOOTING
Low Suction Pressure	Check for low refrigerant.
	Check that Expansion Valve isn't restricted.
	Check that Liquid Line or Filter isn't restricted.
	Check that Evaporator Motors are working.
	Check for Superheat setting.
	Check that the Thermostatic Element charge isn't depleted.
	Check that the Coil is not iced up.
High Suction Pressure	Check that Refrigerant Charge isn't too high.
	Check that Compressor Valves aren't faulty.
	Check that there is no air seepage around Condensing Coil.
	Check that the Cooling Load isn't high.
	Check that Superheat adjustment isn't low.
	Check TXV Bulb Installation a. Poor thermal contact. b. Warm location.
	Check Compressor: Low capacity means it is undersized for its application.

PREVENTIVE MAINTENANCE (TO BE PERFORMED BY TRAINED SERVICE PROVIDER)

WARNING! TURN OFF CASE BEFORE PERFORMING PREVENTIVE MAINTENANCE!

PREVENTIVE MAINTENANCE	FREQUENCY	INSTRUCTIONS
Case Exterior	Monthly	<p>Condensing Coil:</p> <ul style="list-style-type: none"> • Remove grille (by lifting up and off case). • Use air pressure or industrial strength vacuum; clean dust and dirt that may collect on the Condenser Coil. See illustration below. • Caution! Coil fins are sharp. Handle with care! • Replace rear grille.
	Quarterly	<p>Compressor Area: <i>Caution! Be certain to disconnect power from case before cleaning Compressor Area!</i></p> <ul style="list-style-type: none"> • Slide/Roll out from under case. • Use moist cloth to wipe off dust & debris that collects on various parts.
	Quarterly	<p>Evaporator Pan: Disconnect from receptacle box. Remove mounting screw(s) from base. Use a de-scaling solution (such as CLR® that will prevent corrosion, lime and rust) to clean pan. Rinse thoroughly; do not submerge in water.</p>
	Quarterly	<p>Under Case Cleaning: Once refrigeration package is clear of unit, vacuum under case to remove all dust and dirt that may collect under case.</p>
Case Interior	Quarterly	<p>Tub, Coil, Drain, Fan Blade, Motor, Bracket: <i>Disconnect power from the case before cleaning the Tub, Coil, Fan, Motor and Drain Area!</i></p> <ul style="list-style-type: none"> • Remove Decking, Sub-Deck and Fan Shroud. • Use vacuum to clean Evaporator Coils. • Clean Tub, Coil and Drain with warm water, clean cloth, brush and mild soap solution. • Remove any debris that may clog drain. • Clean Fan Blade, Motor and Bracket by wiping down with moist cloth.

CAREL

ir33 platform

Integrated Electronic
Microprocessor Controller



Programming The Instrument

To Modify The Setpoint

Set Press and hold the "SET" key for at least 1 second.

▲/aux **def/▼** 2. Use arrow keys ▲ ▼ on temperature controller to increase (or decrease) the setpoint.

Set 3. Quickly press and release the "SET" key again.

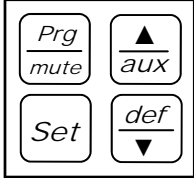

To Modify Defrost, Differential or Other Parameters

Prg/mute **Set** 1. Press & hold "Prg" & "SET" keys together for five (5) seconds; display will flash "0", representing password prompt.

Set 2. Confirm by pressing "SET" key.

▲/aux **def/▼** 3. Press ▲ or ▼ to reach the category to be modified.

Set 4. Press "SET" to modify this selected parameter.

▲/aux **def/▼** 5. Increase or decrease the value using the ▲ or ▼ button respectively.

Set 6. Press the "SET" key to temporarily save the new value and return to the display of the parameter.

Prg/mute 7. Press & hold the "Prg" key for at least 5 seconds to save changes. This action will also mute the audible alarm (buzzer) & deactivate the alarm relay.

How To Change Reading From Fahrenheit (°F) To Celsius (°C)

Prg/mute **Set** 1. Press and hold "Prg" and "SET" keys together for at least 5 seconds; display will show "0", representing password prompt.

Set 2. Confirm by pressing "SET" key.

▲/aux **def/▼** 3. Press ▲ or ▼ until reaching the parameter "15".

Set 4. Press "SET" to modify this selected parameter.

▲/aux **def/▼** 5. Press ▲ or ▼ to change value to desired setting: "0" for Celsius (°C) or "1" for Fahrenheit (°F).

Set 6. Press "SET" key to temporarily save the new value and return to the display of the parameter.

Prg/mute 7. Press & hold "Prg" key for at least 5 seconds to save changes. **Note! All values will automatically convert to new scale. No conversion is required.**

Warning! Save Your Parameter Settings!

1. To store the new parameter values, PRESS and HOLD the "Prg" key for at least 5 seconds.
2. All modifications made to parameters will be lost if you do NOT press a button within 60 seconds. Should this "timeout" occur, normal operational settings (prior to modifications being made) will resume.
3. If the instrument is switched off before pressing the "Prg" key, all modifications to parameters will be lost.

def/▼ **To Activate Manual Defrost**
Press and hold the "def" key for at least 5 seconds.

▲/aux **To Activate / Deactivate Auxiliary Output**
Press and hold the "aux" key for 1 second.

Prg/mute **▲/aux** **To Reset Any Alarms With Manual Reset**
Press and hold the "Prg" and "aux" key for at least 1 second.

CAREL

ir33 platform
**Integrated Electronic
 Microprocessor Controller**



User Interface - Display

ICON	FUNCTION	DESCRIPTION	Normal operation			Start up
			ON	OFF	BLINK	
	COMPRESSOR	ON when the compressor starts. Flashes when the activation of the compressor is delayed by safety times.	Compressor on	Compressor off	awaiting activation	
	FAN	ON when the fan starts. Flashes when the activation of the fan is prevented due to external disabling or procedures in progress.	Fan on	Fan off	awaiting activation	
	DEFROST	ON when the defrost is activated. Flashes when the activation of the defrost is prevented due to external disabling or procedures in progress.	Defrost in progress	Defrost not in progress	awaiting activation	
	AUX	Flashes if the anti-sweat heater function is active, ON when the auxiliary output (1 and/or 2) selected as AUX (or LIGHT in firmware version 3.6) is activated.	AUX auxiliary output active (version 3.6 light auxiliary output active)	AUX auxiliary output not active	Anti-sweat heater function active	
	ALARM	ON following pre-activation of the delayed external digital input alarm. Flashes in the event of alarms during normal operation (e.g. high/low temperature) or in the event of alarms from an immediate or delayed external digital input.	Delayed external alarm (before the time 'A7' elapses)	No alarm present	Alarms in norm. operation (e.g. High/low temperature) or immediate or delayed alarm from external digital input	
	CLOCK	ON if at least one timed defrost has been set. At start-up, comes ON for a few seconds to indicate that the Real Time Clock is fitted.	If at least 1 timed defrost event has been set	No timed defrost event set	Alarm clock	ON if real-time clock present
	LIGHT	Flashes if the anti-sweat heater function is active, ON when the auxiliary output (1 and/or 2) selected as LIGHT is activated (in firmware version 3.6 it does not flash in anti-sweat heater mode and comes on when the dead band output is active).	Light auxiliary output on (version 3.6 dead band auxiliary output active)	Light auxiliary output off	Anti-sweat heater function active (version 3.6 does not flash in anti-sweat heater mode)	
	SERVICE	Flashes in the event of malfunctions, for example E2PROM errors or probe faults.		No malfunction	Malfunction (e.g. E2PROM error or probe fault). Contact service	
	CONTINUOUS CYCLE	ON when the CONTINUOUS CYCLE function is activated. Flashes if the activation of the function is prevented due to external disabling or procedures in progress (E.g.: minimum compressor OFF time).	CONTINUOUS CYCLE operation activated	CONTINUOUS CYCLE function not activated	CONTINUOUS CYCLE operation requested	

Summary Table of Alarm and Signals: Display, Buzzer and Relay

Code	Icon on the display	Alarm relay	Buzzer	Reset	Description
rE	flashing	on	on	automatic	virtual control probe fault
E0	flashing	off	off	automatic	room probe S1 fault
E1	flashing	off	off	automatic	defrost probe S2 fault
E2	flashing	off	off	automatic	probe S3 fault
E3	flashing	off	off	automatic	probe S4 fault
E4	flashing	off	off	automatic	probe S5 fault
LO	flashing	on	on	automatic	probe not enabled low temperature alarm
HI	flashing	on	on	automatic	high temperature alarm
AFr	flashing	on	on	manual	antifreeze alarm
IA	flashing	on	on	automatic	immediate alarm from external contact
dA	flashing	on	on	automatic	delayed alarm from external contact
dEF	on	off	off	automatic	defrost running
Ed1	No	off	off	automatic/manual	defrost on evaporator 1 ended by timeout
Ed2	No	off	off	automatic/manual	defrost on evaporator 2 ended by timeout
Pd	flashing	on	on	automatic/manual	maximum pump down time alarm
LP	flashing	on	on	automatic/manual	low pressure alarm
AtS	flashing	on	on	automatic/manual	autostart in pump down
cht	No	off	off	automatic/manual	high condenser temperature pre-alarm
CHT	flashing	on	on	manual	high condenser temperature alarm
dor	flashing	on	on	automatic	door open too long alarm
EE	flashing	off	off	automatic	E2prom error, unit parameters
EF	flashing	off	off	automatic	E2prom error, operating parameters
ccb	Signal				start continuous cycle request
ccE	Signal				end continuous cycle request
dFb	Signal				start defrost call
dFE	Signal				end defrost call
On	Signal				switch ON
off	Signal				switch OFF
rES	Signal				reset alarms w/manual reset / reset HACCP alarms / reset temp. monitoring

CAREL

ir33 platform
 Integrated Electronic
 Microprocessor Controller



Summary Table of Operating Parameters

CODE	PARAMETER	UOM*	TYPE	MINIMUM	MAXIMUM	DEFAULT
/5	Select Celsius (°C) or Fahrenheit (°F)	flag	C	0	1	For Case Specific Defaults See Serial Label Located Near Electrical Access On Your Case. For Additional Technical Information Call Structural Concepts Technical Service Dept. at 1(800) 433.9489
/c1	Calibration of probe 1	°C/°F	C	-20	20	
/c2	Calibration of probe 2	°C/°F	C	-20	20	
St	Temperature set point	°C/°F	F	r2	r1	
rd	Control delta	°C/°F	F	20	0.1	
dl	Interval between defrosts	hours	F	0	250	
dt1	End defrost temperature, evaporator	°C/°F	F	-50	200	
dP1	Maximum defrost duration, evaporator	min	F	1	250	
d6	Display on hold during defrost	-	C	0	2	
dd	Dripping time after defrost	min	F	0	15	
d/1	Display of defrost probe 1	°C/°F	F	-	-	

* Unit Of Measure

CAREL

ir33 platform

Integrated Electronic
Microprocessor Controller



Changing "Red Meat" and "Produce" Setpoints Using The Thermostat Controller

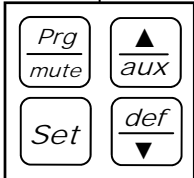

To Increase / Decrease ONLY the Value of the "Red Meat" Temperature Setting:

1. Press and hold the "SET" key for 1 full second (until current setpoint value begins flashing).
2. Use arrow keys ▲ ▼ on temperature controller to increase (or decrease) the "Red Meat" temperature setting.
3. Quickly press and release the "SET" key again.
4. Press & hold "Prg" & "SET" keys together for 5 seconds; display will flash "0", representing the password prompt.
5. Quickly press and release the "SET" key again.
6. Press ▲ or ▼ to reach the "r4" parameter.
7. Press "SET" to access the "r4" parameter.
8. If you RAISE the "Red Meat" setpoint, you must LOWER ▼ the "r4" parameter the same number of degrees in which you RAISED the setpoint.

Example: If you RAISE the "Red Meat" setpoint from 11°F to 12°F, you must use the ▼ button to LOWER the "r4" parameter by 1°F.

9. If you LOWER the "Red Meat" setpoint, you must RAISE ▲ the "r4" parameter the same number of degrees in which you LOWERED the setpoint.

Example: If you LOWER the "Red Meat" setpoint from 15°F to 14°F, you must use the ▲ button to RAISE the "r4" parameter by 1°F.

10. Press the "SET" key to temporarily save the new value and return to the parameter display.
11. Press & hold "Prg" key for at least 5 seconds to save your changes. This action will mute the audible alarm (buzzer) & deactivate the alarm relay.

To Increase / Decrease BOTH the "Red Meat" and "Produce" Temperature Settings:

1. Press and hold the "SET" key for 1 full second (until setpoint value begins flashing).
2. Use arrow keys to increase (or decrease) both the "Red Meat" and "Produce" temperatures at once.
3. Quickly press and release the "SET" key again.

To Increase / Decrease ONLY the Value of the "Produce" Temperature Setting:

1. Press & hold "Prg" and "SET" keys together for 5 seconds; display will flash "0", representing the password prompt.
2. Quickly press and release the "SET" key.
3. Press ▲ or ▼ to reach "r4" parameter.
4. Press "SET" to access the "r4" parameter.
5. Increase or decrease the temperature from the "Produce" setting, use the ▲ or ▼ button respectively.
6. Press the "SET" key to temporarily save the new value and return to parameter display.

7. Press & hold "Prg" key for at least 5 seconds to save changes and mute the audible alarm (buzzer) and deactivate the alarm relay.

Warning! Save Your Parameter Settings!

1. To store the new parameter values, PRESS and HOLD the "Prg" key for at least 5 seconds.
2. All modifications made to parameters will be lost if a button is not pressed within 60 seconds. Should this "timeout" occur, normal operational settings (prior to modifications being made) will resume.
3. If instrument is switched off before pressing the "Prg" key, all modifications to parameters will be lost.

TECHNICAL SERVICE CONTACT INFORMATION & WARRANTY INFORMATION

STRUCTURAL CONCEPTS CORPORATION TECHNICAL SERVICE
PHONE NUMBER: 1.800.433.9489 or For Your Master Service Agent
See WWW.STRUCTURALCONCEPTS.COM/Contact/Master_Service_Agents.asp

WARRANTY INFORMATION (Note: Standard Limited Warranty is at www.Structuralconcepts.com)

All sales by Structural Concepts Corporation (SCC) are subject to the following limited warranty. "Goods" refers to the product or products being sold by SCC.

Warranty; Remedies; Limitations. SCC warrants that if any Goods are found by an authorized representative of SCC not to be of good material or workmanship within one year of the date of shipments SCC will, at its option after inspection by an authorized representative, replace any defective Good or pay the reasonable cost of replacement for any such defective Goods, provided that written notice of the defect is given to SCC within 30 days of the appearance of such defect. If notice is not given within such period, any claim for breach of warranty shall be conclusively deemed to have been waived and SCC shall not be liable under this warranty. If SCC is unable to repair or replace the defective Goods, SCC shall issue a credit to the Purchaser for all or part of the purchase price, as SCC shall determine. The replacement or payment in the manner described above shall be the sole and exclusive remedy of Purchaser for a breach of this warranty. If any Goods are defective or fail to conform to this warranty, SCC will furnish instructions for their disposition. No Goods shall be returned to SCC without its prior consent.

SCC's liability for any defect in the Goods shall not exceed the purchase price of the Goods. SCC SHALL HAVE NO LIABILITY TO PURCHASE FOR CONSEQUENTIAL DAMAGES OF ANY KIND WHATSOEVER, INCLUDING, BUT NOT LIMITED TO, PERSONAL INJURY, PROPERTY DAMAGE, LOST PROFITS, OR OTHER ECONOMIC INJURY DUE TO ANY DEFECT IN THE GOODS OR ANY BREACH OF SCC, SCC SHALL NOT BE LIABLE TO THE PURCHASER IN TORT FOR ANY NEGLIGENT DESIGN OR MANUFACTURE OF THE GOODS, OR FOR THE OMISSION OF ANY WARNING THEREFROM.

SCC shall have no obligation or liability under this warranty for claims arising from any other party's (including Purchaser's) negligence or misuse of the Goods or environmental conditions. This warranty does not apply to any claim or damage arising for or cause by improper storage, handling, installation, maintenance, or from fire, flood, accidents, structural defects, building settlement or movement, acts of God, or other causes beyond SCC's control.

Except as expressly stated herein, SCC makes no warranty, express, implied, statutory or otherwise as to any parts or goods not manufactured by SCC. SCC shall warrant such parts or Goods only (I) against such defects, (II) for such periods of time, and (III) with such remedies, as are expressly warranted by the manufacturer of such parts or Goods. Notwithstanding the foregoing, any warranty with respect to such parts of Goods and any remedies available as a result of a breach thereof shall be subject to all of the procedures, limitations, and exclusions set forth herein.

THE WARRANTIES HEREIN ARE IN LIEU OF ALL WARRANTIES, EXPRESS, IMPLIED, STATUTORY, OR OTHERWISE. IN PARTICULAR, SCC MAKES NO WARRANTY OF MERCHANTABILITY OR FITNESS FOR A PARTICULAR PURPOSE.

No representative, agent or dealer of SCC has authority to modify, expand, or extend this Warranty, to waive any of the limitations or exclusions, or to make any different or additional warranties with respect to Goods.

Period of Limitations. No claim, suit or other proceeding may be brought by Purchaser for any breach of the foregoing warranty or this Agreement by SCC or in any way arising out of this Agreement or relating to the Goods after one year from the date of the breach. In the interpretation of this limitation on action for a breach by SCC, it is expressly agreed that there are no warranties of future performance of the goods that would extend that period of limitation herein contained for bringing an action.

Indemnifications. Purchaser agrees to indemnify, hold harmless, and defend SCC if so requested, from any and all liabilities, as defined herein, suffered, or incurred by SCC as a result of, or in connection with, any act, omission, or use of the Goods by Purchaser, its employees or customers, or any breach of this Agreement by Purchaser. Liabilities shall include all costs, claims, damages, judgments, and expenses (including reasonable attorney fees and costs).

Remedies of SCC. SCC's rights and remedies shall be cumulative and may be exercised from time to time. In a proceeding or action relating to the breach of this Agreement by Purchaser, Purchaser shall reimburse SCC for reasonable costs and attorney's fees incurred by SCC. No waiver by SCC of any breach of Purchaser shall be effective unless in writing nor operate as a waiver of any other breach of the same term thereafter. SCC shall not lose any right because it has not exercised it in the past.

Applicable Law. This Agreement is made in Michigan and shall be governed by and interpreted according to Michigan law. Any lawsuit arising out of this Agreement or the Goods may be handled by a federal or state court whose district includes Muskegon County, Michigan, and Purchaser consents that such court shall have personal jurisdiction over Purchaser.

Miscellaneous. If any provision of this Agreement is found to be invalid or unenforceable under any law, the provision shall be ineffective to that extent and for the duration of the illegality, but the remaining provisions shall be unaffected. Purchaser shall not assign any of its rights nor delegate any of its obligations under this Agreement without prior written of SCC. This Agreement shall be binding upon and inure to the benefit of SCC and Purchaser and each of their legal representatives, successors and assigns.

SCC warrants its products to be free of defects in materials and workmanship under normal use and service for a period of one (1) year from the date of delivery.

This warranty is extended only to the original purchaser for use of the Goods. It does not cover normal wear parts such as plastic tongs, tong holders, tong cables, bag holders, or acrylic dividers.

General Conditions. All service labor and/or parts charges are subject to approval by SCC. Contact the Customer Service Department in writing or call 231-798-8888.

All claims must contain the following information: (1) model & serial code number of equipment; (2) the date and place of installation; (3) the name and address of the agency which performed the installation; (4) the date of the equipment failure; and (5) a complete description of the equipment failure and all circumstances relating to that failure.

Once the claim has been determined to be a true warranty claim by SCC's Customer Service Department, the following procedure will be taken: (1) replacement parts will be sent at no charge from SCC on a freight prepaid basis; (2) reimbursement for service labor will be paid if the following conditions have been met— (a) prior approval of service agency was awarded from the Customer Service Department; and (b) an itemized statement of all labor charges incurred is received by the Customer Service Department. The cost of the service labor reimbursement will be based on straight time rates and reasonable time for the repair of the defect.

If problems occur with any compressor, notify SCC's Customer Service Department immediately. Any attempt to repair or alter the unit without prior consent from the Customer Service Department will render any warranty claim null and void. This warranty and protection plan does not apply to any condensing unit or any part thereof which has been subject to accident, negligence, misuse, or abuse, or which has not been operated in accordance with the manufacturer's recommendations or if the serial number of the unit has been altered, defaced, or removed.

Limit of Liability. The limit of liability of SCC toward the exchange cost of the original condensing unit, F.O.B. SCC, Norton Shores, MI, of each motor-compressor assembly replaced during the warranty shall not exceed manufacturer's current established wholesaler's exchange price and in no case shall the labor of removing or replacing the motor-compressor or parts thereof be the responsibility of SCC.



**Structural
Concepts**

888 E. Porter Road · Muskegon, MI 49441 Phone: 231.798.8888 Fax: 231.798.4960 www.structuralconcepts.com